

Termination of horizontal flues

(Withdrawn – January 2024)

The Technical Guidance Notes are produced by NHBC as guidance solely for our builder customers as to how to interpret the technical requirements in relation to the warranty cover provided by NHBC under its Buildmark, Buildmark Choice, Buildmark Link, Buildmark Solo, Buildmark Connect or any similar product from time to time. It has not been created or intended for distribution or use outside of that purpose. The information contained in this Technical Guidance Note does not constitute advice and is not to be relied upon by any third party. Nothing in this Technical Guidance Note is intended to, nor should it be taken to, create any legal or contractual relationship. Any third party who chooses to rely upon the information contained in the Technical Guidance Notes shall do so entirely at their own risk and NHBC accepts no duty of care or liability, however caused, in connection with its use or reliance by any third party.

Question

What is the interpretation of an 'opening' in relation to the position of a horizontal gas or oil flue terminal?

Considerations

- NHBC Standards Chapter 6.8, Appendix E & F Approved Document J (England & Wales), Part L Building Regulations (N Ireland) and Technical Handbook – Domestic section 3 (Scotland), quote the minimum distances gas and oil flue terminals should be located from openings into a building.
- The flue terminal should be located where the products of combustion will safely disperse without entering the building through openable windows, doors or permanent openings such as air vents.

Answer

Figures 1 to 6 show the minimum distances gas and oil flue terminals should be located from 'openings', e.g. window, door or air vent (e.g. trickle vent, extract fan outlet). Where an installation relates to more than one of the figures shown the more onerous dimension should be used.

The distances quoted are horizontal distances measured parallel to the face of the wall from the edge of the 'opening' to the outer casing of the flue.

Termination of horizontal flues

(Withdrawn - January 2024)

Flues serving oil-fired appliances (with pressure jet burners)

Figure 1

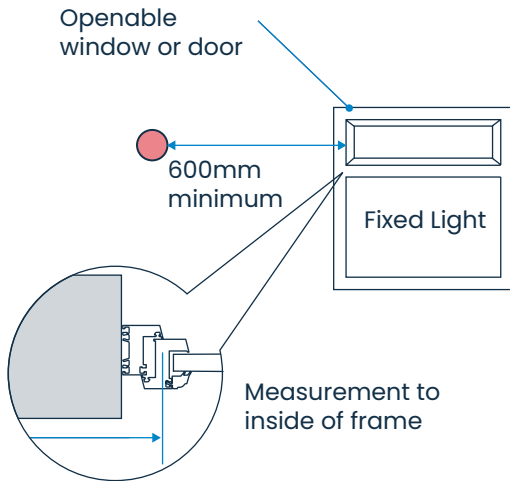

Figure 2

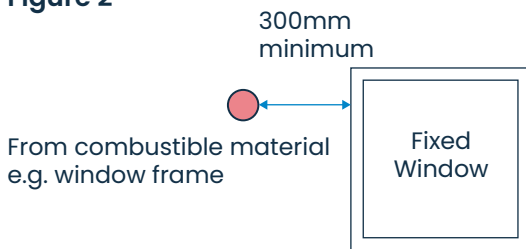
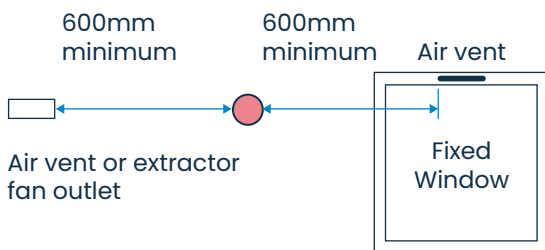

Figure 3



Oil

'Opening' means an openable window, door or a permanently open air vent (including trickle vents and extractor fan outlet).

Flues serving gas appliances (fan flued)

Figure 4

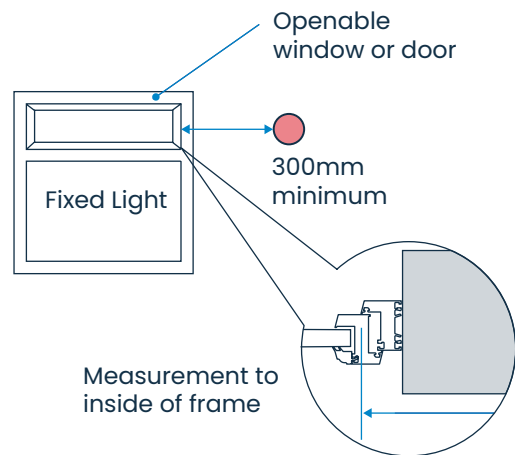

Figure 5

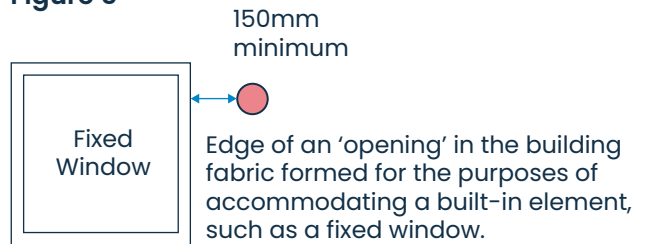
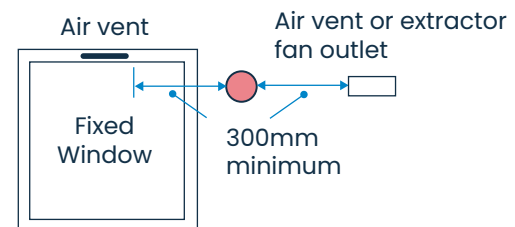

Figure 6



Gas

'Opening' means an openable window, door, or a fixed opening such as an air vent/extractor fan outlet. 'Opening' can also refer to an opening in the building fabric as shown in Figure 5.