

Material specifications for DPC cavity trays in masonry clad timber frame construction

(June 2023) (First issue)

Applicable sites

Warranty and Building Control sites registered with NHBC

Applicable regions

This Technical Guidance Note applies to England, Wales, Scotland, and Northern Ireland.

Background and NHBC Standards

NHBC Technical Guidance Note 6.1/38, published in November 2022, deals with DPC cavity trays in masonry cavity walls and states that flexible DPC used as a cavity tray should be designed to prevent the downward passage of water or moisture through the tray, meet the requirements of BS EN 14909 and have independent technical approval that confirms its suitability as a cavity tray. This guidance was fully incorporated into the 2023 NHBC Standards.

NHBC Standards Chapter 6.2 states that masonry cladding to timber frame buildings should be installed in accordance with Chapter 6.1, and so cavity tray material and certification requirements for masonry cavity walls are also applicable to cavity trays over openings, at abutments and where fitted at sole plate level in masonry clad timber frame construction.

At present there are several manufacturers which can supply DPC cavity tray materials that are CE marked to BS EN 14909 and have satisfactory assessment by an appropriate independent technical approvals authority. However, these approvals only cover their use in solid or cavity walls of brick, block, stone or concrete and do not mention timber frame buildings clad with masonry.

Key Technical Considerations

Cavity trays over openings, at abutments, and where fitted across cavities at sole plate level

Flexible (plastic or rubber) DPC used as a cavity tray over openings, at abutments, and where fitted at sole plate level should be designed to prevent the downward passage of water or moisture through the tray. Materials should be CE Marked to BS EN 14909 and have satisfactory assessment by an appropriate independent technical approvals authority accepted by NHBC suitable for the intended application. Manufacturers' literature confirming suitability for use as a cavity tray should be readily available along with their recommendations for appropriate use and installation. Cavity trays used in the above context should be installed in accordance NHBC Standards clauses 6.1.17 and 6.2.10, with a fall from the inner to outer leaf, lapped behind the breather membrane and securely fixed to the sheathing, and built into the masonry outer leaf.

Low-density polyethylene DPC conforming to BS 6515 alone is not suitable for this application.

DPCs around openings and over horizontal and vertical timber cavity barriers

NHBC will accept low-density polyethylene DPC conforming to BS 6515 for the following applications:

- Timber cavity barriers installed to sill and jambs of window and door openings - timber cavity barriers installed at the jambs and sills of window and door openings should be protected from moisture with a DPC installed over the face in contact with the masonry cladding and lapped into the timber frame window reveal. See Figure 1.
- Vertical timber cavity barriers - vertical timber cavity barriers should be protected from moisture with a DPC installed over the face in contact with the masonry cladding. See Figure 2.
- Horizontal timber cavity barriers - Horizontal timber cavity barriers, except under eaves, should be protected with a DPC arranged to shed moisture away from the sheathing, with a 100mm upstand lapped behind the breather membrane. See Figure 3.

Material specifications for DPC cavity trays in masonry clad timber frame construction

(June 2023) (First issue)

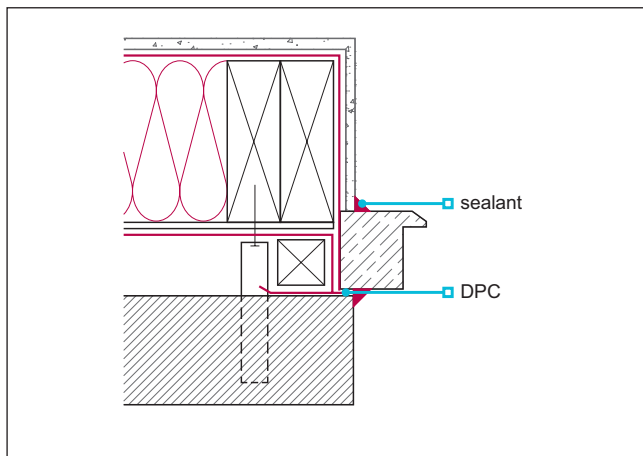

Figure 1 - Timber cavity barrier to window/door jamb

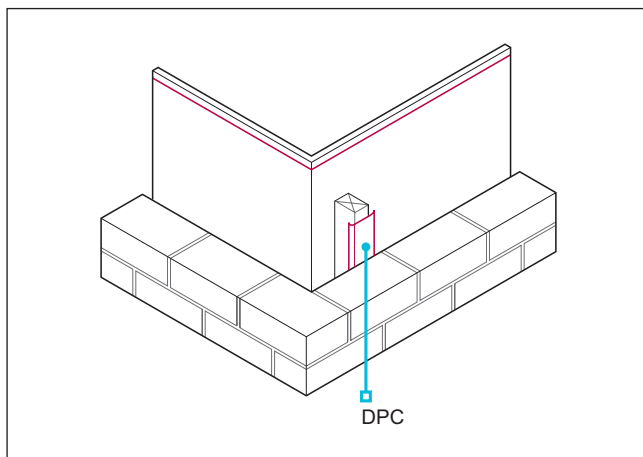

Figure 2 - Vertical timber cavity barrier

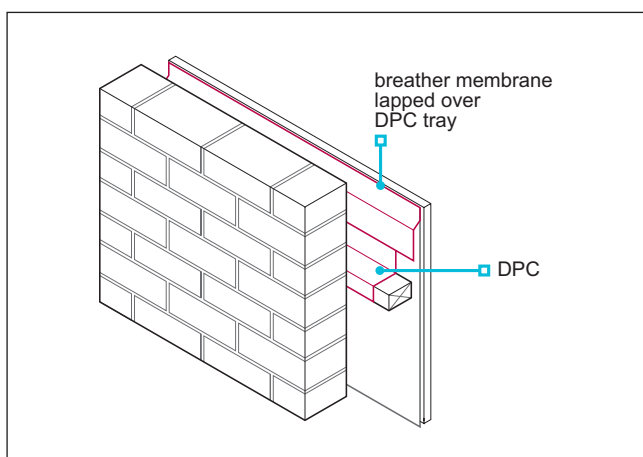

Figure 3 - Horizontal timber cavity barrier

Drainage and ventilation

Drainage and ventilation should be provided to external wall cavities in accordance with NHBC Standards clause 6.2.10.

Transition Arrangements

We hereby give notice that for all plots starting or at DPC level as of 1st July 2023, flexible plastic and rubber DPC materials used to form cavity trays over openings, at abutments, and where fitted at sole plate level in masonry clad timber frame buildings, should be CE Marked to BS EN 14909 and the manufacturer's literature should confirm its suitability for use as a cavity tray. From the 1st January 2024, these materials should also have satisfactory assessment by an appropriate independent technical approvals authority accepted by NHBC covering their use in this specific application.