

View outside main entrance door

(November 2024) (Second issue – supersedes April 2011)

The Technical Guidance Notes are produced by NHBC as guidance solely for our builder customers as to how to interpret the technical requirements in relation to the warranty cover provided by NHBC under its Buildmark, Buildmark Choice, Buildmark Link, Buildmark Solo, Buildmark Connect or any similar product from time to time. It has not been created or intended for distribution or use outside of that purpose. The information contained in this Technical Guidance Note does not constitute advice and is not to be relied upon by any third party. Nothing in this Technical Guidance Note is intended to, nor should it be taken to, create any legal or contractual relationship. Any third party who chooses to rely upon the information contained in the Technical Guidance Notes shall do so entirely at their own risk and NHBC accepts no duty of care or liability, however caused, in connection with its use or reliance by any third party.

Question

When is glazing considered acceptable for providing a view outside the main entrance door?

Considerations

- A clear view of the area immediately outside a main entrance door is required for security purposes to enable a caller to be identified from within the property without having to open the entrance door.
- NHBC Standards clause 6.7-D4(c) refers to four methods of providing an acceptable view outside a main entrance door i.e. door viewer, closed circuit television, glazed door or convenient window.

Answer

Where glazing is used it should be of a suitable size and position to provide a view of a caller standing outside the main entrance door. That view should be achievable from a standing position without having to press one's face against the glass.

The following arrangements are acceptable examples:

1. A pane set within the door or in an adjoining side screen/window (see figure 1)
2. A convenient window in an adjoining room such as a bay window (see figure 2).

A window set flush within a straight wall, in line with the main entrance door, (see figure 3) is not acceptable.

View outside main entrance door

(November 2024) (Second issue – supersedes April 2011)

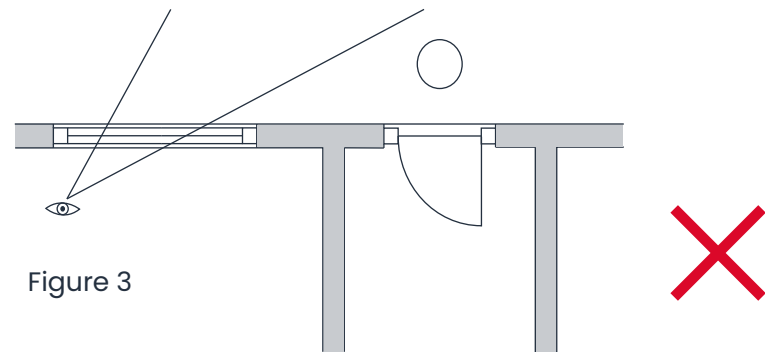
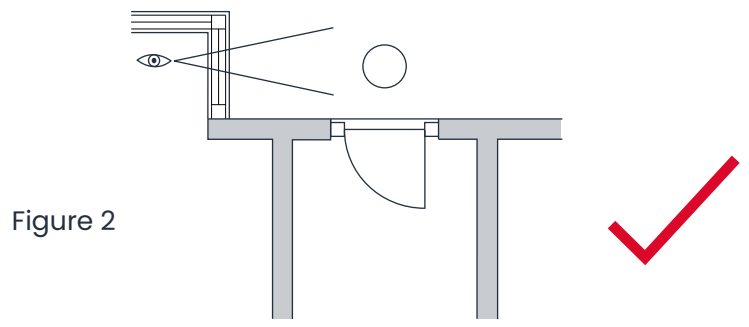
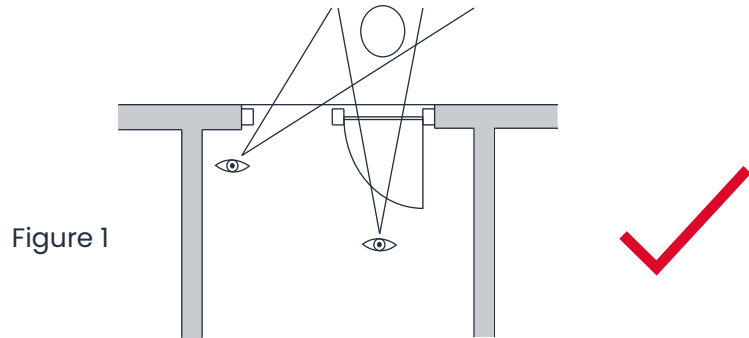

NHBC, NHBC House, Davy Avenue, Knowlhill, Milton Keynes, Bucks MK5 8FP
Tel: 0344 633 1000 Web: nhbc.co.uk

National House-Building Council (NHBC) is authorised by the Prudential Regulation Authority and regulated by the Financial Conduct Authority and the Prudential Regulation Authority for carrying on insurance business and insurance distribution activities.

NHBC is registered in England and Wales under company number 00320784. NHBC's registered address is NHBC House, Davy Avenue, Knowlhill, Milton Keynes, Buckinghamshire, MK5 8FP. Note that only certain parts of our products and services are within the scope of UK financial services regulations. For more information on our products and services, please see our website nhbc.co.uk or your NHBC product documentation.