

---

# NHBC Standards

---

2013

Effective from 1 January 2013



# 'Welcome'

## to the 2013 edition of NHBC's Standards.

---

### What's new in 2013?

#### Major change:

- The revised Chapter 7.2 'Pitched roofs' published in October 2011 and effective from January 2012, has been incorporated into the main body of the Standards. Following feedback from industry the guidance in this Chapter for detailing tiles and slates at the verge has been slightly amended.
- Chapters 6.7 'Doors, windows and glazing' and 6.9 'Curtain walling and cladding' have had guidance added to reflect multiple door and window frame assemblies either contained within a storey or spanning more than one storey.

#### Minor changes:

- Chapter 1.1 'Introduction and Technical Requirements' has been reviewed and some minor changes made.
- Table 3 of Appendix 2.1-A has been replaced with a table based on BS EN 206-1. This is to align the Standards with 'European' terminology now commonly used by industry.
- The table in Appendix 6.4-B that provided guidance for the protection of metal components has been removed and a new Appendix 6.1-F has been added. Again, this aligns the Standards with 'European' terminology and also clarifies guidance for the protection of metal ancillary components such as lintels, wall ties and restraint straps.

| All minor changes are identified by a blue vertical marker adjacent to the relevant paragraph and the revised text underlined.

#### Please note:

Throughout this edition of the Standards coloured text is used as follows:

- **Red text** = Technical Requirements that must be met by the builder.
- **Black text** = Performance Standards for Design, Materials and Sitework.
- **Blue text** = Guidance (on how the Performance Standards may be met).

# NHBC Standards 2013

Effective from 1 January 2013

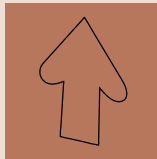

## More copies

For more copies of NHBC Standards, a CD-ROM version, or to subscribe to Standards Extra, call us on  
**Tel: 01908 746846**

## Buy Online

To buy Standards online, visit our website at  
**[www.nhbcbuilder.co.uk/NHBCshop/TechnicalStandards](http://www.nhbcbuilder.co.uk/NHBCshop/TechnicalStandards)**

## Technical Helpline

For Technical help and advice, call our Technical helpline on  
**Tel: 01908 747384.**  
e-mail: [technical@nhbc.co.uk](mailto:technical@nhbc.co.uk)

## IT Support

If you need assistance with the HTML version on the CD-ROM, please call the IT Response Centre on  
**Tel: 01908 747474.**  
e-mail: [itresponsecentre@nhbc.co.uk](mailto:itresponsecentre@nhbc.co.uk)

## Contact Us

### Milton Keynes

NHBC, NHBC House; Davy Avenue,  
Knowlhill, Milton Keynes, Bucks MK5 8FP  
Tel: 0844 633 1000 Fax: 0844 633 0022

### Edinburgh

NHBC Scotland, Suite 4,  
5 New Mart Place, Edinburgh EH14 1RW  
Tel: 0844 633 1000 Fax: 0870 850 4495

### Belfast

NHBC, Northern Ireland & Isle of Man  
Holyrood Court,  
59 Malone Road, Belfast BT9 6SA  
Tel: 02890 386000 Fax: 0844 633 0022

# Contents

---

## PART 1 General information

- 1.1 Introduction to the Standards and Technical Requirements
  - 1.2 A consistent approach to finishes
  - 1.3 No longer allocated
  - 1.4 Cold weather working
- 

## PART 2 Materials

- 2.1 Concrete and its reinforcement
  - 2.2 No longer allocated
  - 2.3 Timber preservation (natural solid timber)
- 

## PART 3 Ancillary technologies

- 3.1 Low or zero carbon technologies
- 

## PART 4 Foundations

- 4.1 Land quality - managing ground conditions
  - 4.2 Building near trees
  - 4.3 No longer allocated
  - 4.4 Strip and trench fill foundations
  - 4.5 Raft, pile, pier and beam foundations
  - 4.6 Vibratory ground improvement techniques
- 

## PART 5 Substructure and ground floors

- 5.1 Substructure and ground bearing floors
  - 5.2 Suspended ground floors
  - 5.3 Drainage below ground
- 

## PART 6 Superstructure (excluding roofs)

- 6.1 External masonry walls
  - 6.2 External timber framed walls
  - 6.3 Internal walls
  - 6.4 Timber and concrete upper floors
  - 6.5 Steelwork
  - 6.6 Staircases
  - 6.7 Doors, windows and glazing
  - 6.8 Fireplaces, chimneys and flues
  - 6.9 Curtain walling and cladding
  - 6.10 Light steel framed walls and floors
- 

## PART 7 Roofs

- 7.1 Flat roofs and balconies
  - 7.2 Pitched roofs
- 

## PART 8 Services and internal finishing

- 8.1 Internal services
  - 8.2 Wall and ceiling finishes
  - 8.3 Floor finishes
  - 8.4 Finishings and fitments
  - 8.5 Painting and decorating
- 

## PART 9 External works

- 9.1 Garages
  - 9.2 Drives, paths and landscaping
- 

## PART 10 No longer allocated



---

# Part 1

## General information

---

- 1.1 Introduction and Technical Requirements
- 1.2 A consistent approach to finishes
- 1.3 No longer allocated
- 1.4 Cold weather working





**Part 1 General information**

---

# Chapter 1.1

Introduction and Technical Requirements

---

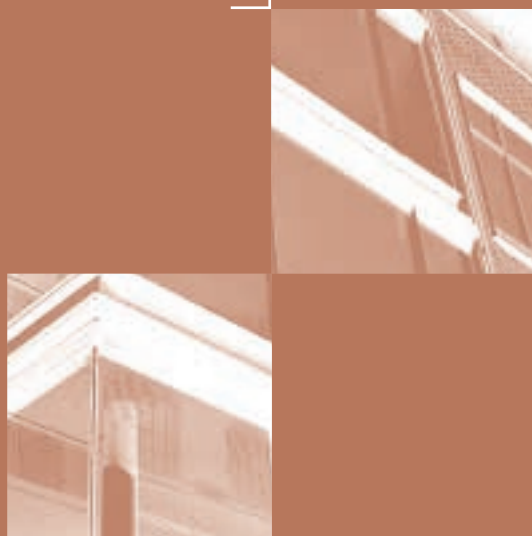

## CONTENTS

<b>INTRODUCTION TO THE STANDARDS</b>		Page
Application of the Standards		1
Composition of the Standards		1
Technical Requirements		1
Performance Standards		1
Guidance		1
Limitations on use		1
Interpretation		1
Testing		1
Standards and Codes of Practice		1
Tolerances		1
Acknowledgements		1
<b>TECHNICAL REQUIREMENTS</b>		
Statutory requirements	R1	2
Design requirement	R2	2
Materials requirement	R3	2
Workmanship requirement	R4	2
Structural design requirement	R5	2
<b>INDEX</b>		4

## SCOPE

This Chapter introduces the Standards and gives the Technical Requirements.

NHBC Standards do not apply to:

- health and safety matters relating to building operations
- handling and use of certain building materials
- planning matters except where specifically referred to in these Standards.

Such matters are covered by statutory requirements.

## INTRODUCTION TO THE STANDARDS

### APPLICATION OF THE STANDARDS

The NHBC Standards give the Technical Requirements, Performance Standards and Guidance for the design and construction of dwellings acceptable to NHBC. In the Standards, a DWELLING means a HOME as defined in the NHBC Rules.

The Standards come into effect for every NHBC registered home whose foundations are begun on or after the 1 January 2013 and apply throughout the UK, unless otherwise stated.

### COMPOSITION OF THE STANDARDS

The Standards are divided into 10 Parts, each covering a particular aspect. All parts may not currently contain chapters. The Parts follow the usual construction process; from design through to construction on site.

In general, each Chapter is made up of sections dealing with Design, Materials and Sitework.

## TECHNICAL REQUIREMENTS

In this Chapter, the **Technical Requirements, which MUST be met by the Builder, are in red.**

### PERFORMANCE STANDARDS

The Technical Requirements are supported by Performance Standards which generally relate to Design, Materials and Sitework and are in black.

Alternative standards of performance will be acceptable ONLY if, in the opinion of NHBC, the Technical Requirements are met and the standard achieved is not lower than the stated Performance Standard.

If the Performance Standards are followed the Technical Requirements will be met.

## GUIDANCE

Guidance on how the Performance Standard may be met is in light blue.

Diagrams may contain text in red. This is to highlight points and has no mandatory status.

Guidance is based on normal construction procedures and recommended practices which have been shown to be satisfactory and acceptable over time. NHBC will consider alternative methods to meet

specific requirements, subject to prior consultation and evaluation.

### LIMITATIONS ON USE

The Technical Requirements, Performance Standards and Guidance do not form a complete specification and should not be used as such in contracts.

Individual Chapters cover, as far as practical, the requirements for particular elements of construction. To avoid repetition, some cross-referencing is made to other Chapters, where necessary.

### INTERPRETATION

Occasionally, there may be disagreements on how Technical Requirements and Performance Standards are to be interpreted. Such cases are usually resolved through further consultation, failing which NHBC will exercise its right to decide, subject to appeal to an arbitrator under NHBC Rules.

### TESTING

In accordance with the Rules for Builders and Developers registered with NHBC samples of materials, products and systems shall (where required) be made available for testing to ensure that they comply with Technical Requirement R3.

### STANDARDS AND CODES OF PRACTICE

Where NHBC Standards refer to British Standards or Codes of Practice, other authoritative documents or technical approval certification, the documents shall be the editions current at the time of Building Regulation approval, unless other recommendations are made by NHBC in writing.

The British Standards and Codes of Practice referred to in the NHBC Standards include British Standards or Codes of Practice and those made under the Construction Products Directive (89/106/EEC) and, in particular, appropriate European Technical Specifications approved by a European Committee for Standardisation (CEN).

The UK accepts harmonised standards which are dual numbered British Standards. These have numbers issued by the British Standards Institution (BSI), the International Standards Organisation (ISO) and a European Committee for Standardisation (CEN).

Example: BS EN ISO 9000-1

Unless NHBC provides written notification to the contrary, the use of guidance in authoritative documents not mentioned in the NHBC Standards, such as BRE Digests, can be considered for acceptance.

### TOLERANCES

All measurements shall be within acceptable tolerances. Where it is applicable, account should be taken of Chapter 1.2 'A consistent approach to finishes'. In other situations, tolerances will be those currently acceptable in the industry.

### ACKNOWLEDGEMENTS

NHBC is indebted to the members of the Standards Review Group, Scottish and Northern Ireland Technical Sub Committees and Standards Committee for all their work.

NHBC also wishes to acknowledge the help given by consultants, authoritative organisations, individuals and staff.

A list of the organisations who nominate representatives to the Standards Committee, Scottish Technical Sub Committee and the Northern Ireland Technical Sub Committee is shown below.

#### Standards Committee

Construction Products Association  
 Council of Mortgage Lenders  
 Federation of Master Builders  
 Home Builders Federation  
 Institution of Civil Engineers  
 DCLG (Department for Communities and Local Government) (observer)  
 Royal Institution of Chartered Surveyors

#### Scottish Technical Sub Committee

Homes for Scotland  
 Royal Incorporation of Architects in Scotland/Royal Institute of British Architects  
 Scottish Branch of the Chartered Institution of Building  
 Scottish Branch of the Royal Institution of Chartered Surveyors  
 Scottish Group of the Association of Consulting Engineers  
 Scottish Building Standards Division

#### Northern Ireland Technical Sub Committee

Construction Employers Federation  
 Royal Society of Ulster Architects

## TECHNICAL REQUIREMENTS

### The Builder shall ensure that the work complies with the Technical Requirements

#### R1 Statutory requirements

Work shall comply with all relevant Building Regulations and other statutory requirements relating to the completed construction work

NHBC will generally accept work that accords with relevant Building Regulations/Building Standards and supporting documents. Exceptions would be where NHBC has a higher standard.

#### R2 Design requirement

Design and specification shall provide satisfactory performance

Account shall be taken of:

- (a) The land quality, including:
  - (i) climate
  - (ii) topography
  - (iii) geology and ground conditions
  - (iv) contamination
  - (v) workings below ground
  - (vi) previous use of the site
  - (vii) any other aspect, on or adjacent to the site, which could affect the design.

Where appropriate, the land quality will have to be determined by a person acceptable to NHBC.
- (b) The structural adequacy of the works. The design, with appropriate factors of safety, shall satisfactorily allow for loads during and after construction and for their transfer to the supporting structure, or foundation, without undue movement, including:
  - (i) self weight
  - (ii) all imposed loads, including wind loads
  - (iii) construction loads.
- (c) The geographical location of the site, including:
  - (i) exposure to wind and rain
  - (ii) topography.
- (d) The position of the dwelling on the site, especially with reference to the dwelling's exposure to the weather, including at early stages in the development of a site, even if it is eventually protected by structures built later.
- (e) The position of building elements within the construction works, including the inter-relationship of materials and constructions.
- (f) The security of the dwellings.

#### R3 Materials requirement

All materials, products and building systems shall be suitable for their intended purpose

The structure of the home shall, unless specifically agreed otherwise in writing with NHBC, have a life of at least 60 years. Individual components and assemblies, not integral to the structure, may have a lesser durability and need planned maintenance, repair or replacement during that period.

Account shall be taken of the use and location of materials, products and building systems in relation to:

- durability of both the structure and individual components and assemblies
- geographical location
- position on the site
- position within the structure.

Materials, products and building systems will normally be acceptable if they comply with the following:

- (a) MATERIALS AND PRODUCTS USED FOR CRITICAL FUNCTIONS
 

Functions critical to performance are: structure, fire resistance, weatherproofing, durability, thermal and sound insulation, services including heating appliances and flues.

Any of the following are acceptable:

  - (i) performance in accordance with standards set by NHBC, or
  - (ii) where no NHBC standard is set, compliance with the relevant British Standard or equivalent European Technical Specification approved by a Committee for Standardisation, provided they are used in accordance with the relevant Code of Practice, or
  - (iii) compliance with standards not lower than those defined in a relevant British Standard specification or equivalent, provided their use is accepted by NHBC, or
  - (iv) satisfactory assessment by an appropriate independent technical approvals authority accepted by NHBC, or
  - (v) use of materials and products in accordance with well established satisfactory custom and practice, provided that such custom and practice is acceptable to NHBC, or
  - (vi) acceptance, in writing, by NHBC that the quality and use is satisfactory.
- (b) MATERIALS AND PRODUCTS USED FOR NON-CRITICAL FUNCTIONS
 

Compliance with the above acceptance criteria for

critical functions or strictly in accordance with manufacturers' recommendations for the specific use.

- (c) RECLAIMED MATERIALS
 

Reclaimed materials may only be re-used with the prior agreement of NHBC. Independent certification of suitability may be required.
- (d) PROPRIETARY BUILDING SYSTEMS
 

Reference should be made to R3(a), (iv).
- (e) TIMBER DURABILITY
 

Reference should be made to Chapter 2.3 'Timber preservation (natural solid timber)' (each section).

#### Note

Equivalents to British Standards or technical approvals authority shall be those accepted in the UK.

#### R4 Workmanship requirement

All work shall be carried out in a proper, neat and workmanlike manner

The Builder shall ensure that:

- (a) the conditions of the materials, products and the completed work are satisfactory
- (b) appropriate precautions are taken to prevent damage
- (c) account is taken of the following:
  - (i) the requirements of the design
  - (ii) suitable methods of unloading and handling
  - (iii) proper protection during storage
  - (iv) use of correct installation methods
  - (v) protection against weather during construction (including excessive heat, cold, wetting or drying)
  - (vi) protection against damage by following trades.

#### R5 Structural design requirement

Structural design shall be carried out by suitably qualified persons in accordance with British Standards and Codes of Practice

The following shall be designed by Chartered Civil or Structural Engineers whose status (including professional indemnity insurance) is accepted by NHBC:

- (a) foundations on hazardous ground where the hazard makes special consideration necessary. (Note. This would not apply to matters for which NHBC sets Standards, such as building near trees, except where specified to the contrary)
- (b) foundations and superstructure of every building over three storeys in height
- (c) certain types of foundations and retaining walls, as required in the individual Chapters of the NHBC Standards



- (d) any structural element which is not based on specific design criteria as laid down in the Chapters of the NHBC Standards
- (e) any dwelling not constructed in accordance with UK traditional practice.

**Note**

Other structural elements may be designed by a Chartered Civil or Structural Engineer or others whose status (including professional indemnity insurance) is accepted by NHBC.

The structural design shall take account of the durability requirement in Technical Requirement R3 Materials requirement.

In England, Wales, Northern Ireland and the Isle of Man, structural design may be undertaken by the Builder's own Engineer or a Consulting Engineer employed by the Builder. Where specialist subcontractors undertake the design, it must be separately appraised by the Builder's own Engineer or by a Consulting Engineer employed by the Builder to ensure that the site investigation, choice of foundations, siting and construction of dwellings are properly taken into account and that the design is appropriate for the loading and conditions.

In Scotland, the Engineer shall be independent of the Builder and specialist subcontractor.

Account shall be taken of all parts of the following British Standards

(Eurocodes) and their respective National Annexes.

BS EN 1990	Basis of structural design (Eurocode 0)
BS EN 1991	Actions on structures (Eurocode 1)
BS EN 1992	Design of concrete structures (Eurocode 2)
BS EN 1993	Design of steel structures (Eurocode 3)
BS EN 1995	Design of timber structures (Eurocode 5)
BS EN 1996	Design of masonry structures (Eurocode 6)
BS EN 1997	Geotechnical design (Eurocode 7)

Alternatively, designs in accordance with BS 8103 'Structural design of low rise buildings' will be acceptable.

The Builder shall:

- require the Engineer to issue clear instructions for site personnel

- not permit departure from the design without the Engineer's written consent
- require the Engineer or his representative to carry out such inspections as may be required by NHBC to ensure the adequacy of the design and construction.

The Builder shall ensure that the Engineer visits the site during construction:

- (i) when the foundations have been designed under this Technical Requirement, or
- (ii) when specifically required by NHBC in these Standards.

The Engineer shall satisfy himself that the design is suitable for the conditions encountered on the site of each dwelling.

When requested by NHBC, the Builder shall:

- produce such design documents, calculations and prescribed forms of certification as NHBC requires for scrutiny
- provide design documents and assembly instructions, solely for the use of NHBC staff
- arrange for NHBC staff to have access to places where off-site fabrication is taking place.

## INDEX

<b>A</b>		<b>I</b>		<b>S</b>	
Acknowledgements	1	Interpretation	1	Standards committees	1
<b>B</b>		<b>L</b>		Statutory requirements	2
British Standards	1	Land quality	2	Structural design	2
Building Systems	2	Limitations	1	<b>T</b>	
<b>C</b>		Low rise buildings	3	Technical requirements	1
Codes of practice	1	<b>M</b>		Testing	1
Critical functions	2	Materials, critical functions	2	Timber durability	2
<b>D</b>		Materials, non-critical functions	2	Tolerances	1
Design requirements	2	Materials, requirements	2	<b>W</b>	
<b>F</b>		<b>P</b>		Workmanship	2
Foundations	2	Performance standards	1		
<b>G</b>		<b>R</b>			
Guidance	1	Reclaimed materials	2		

# Chapter 1.2

A consistent approach to finishes

---



# 1.2 A consistent approach to finishes

## CONTENTS

### DESIGN

There are no specific Design implications

Clause Page

### MATERIALS

There are no specific Material implications

### SITWORK

External walls - tolerances	S1	1
External walls - appearance	S2	2
External works	S3	3
Doors and windows	S4	3
Glazing	S5	4
Walls and ceilings - tolerances	S6	4
Walls and ceilings - appearance	S7	4
Floors	S8	5
Tile finishes	S9	5
Joint sealants	S10	5
Other surfaces and finishes	S11	5
Fitted furniture	S12	5

### INDEX

6

## SCOPE

This Chapter gives guidance on the suitability of the finishes in new homes.

## INTRODUCTION

This Chapter is intended to apply at the time the home is substantially complete ready for NHBC pre-handover inspection. It will be used by NHBC both during the construction process and when conducting Resolutions under Section 2 of the Buildmark insurance cover.

The Chapter should also be considered in conjunction with relevant performance standards and guidance contained elsewhere in the NHBC Standards. Additional information is also contained in the NHBC publication 'Guide to your new home' relating generally to normal household maintenance.

Some elements may be subject to the effects of normal thermal or drying movement and this may occur both before and after completion. A commentary has been added to a number of clauses to provide background information.

Many sources of information relating to tolerances and finishes have been reviewed in the preparation of this Chapter. The tolerances and finishes given here are considered to be appropriate for the house-building industry and take precedence over other recommendations.

This Chapter is not intended to deal with every situation that may arise and discretion should be exercised in its application in specific circumstances. The nature and extent of work necessary to remedy minor variations from the tolerances and finishes given should be proportionate and appropriate to the circumstances.

**SITWORK STANDARDS**

**EXTERNAL WALLS - TOLERANCES**

**1.2 - S1 External walls shall be built to appropriate tolerances**

Some of the materials used to construct external walls are not uniform because of their manufacturing process, nor are they intended to be. In consequence, some external walls will have variations and irregularities. Where reclaimed materials are used there may be even greater irregularities and these characteristics are often intended as an aesthetic feature. The recommended tolerances are intended to be applied in the spirit of this overall context.

**Commentary**

- bricks and other materials vary in size and appearance for a number of reasons and in consequence the tolerances and finishes stated may not always be appropriate, especially where reclaimed stock is used. Such materials will need to be considered separately
- the tolerances described generally apply to entire areas of walling, complete panels and the like, and not to the elements of the construction, such as individual bricks
- the tolerances do not apply to design features and similar constructional details which are not intended to lie within the limits stated in this document (e.g. quoins, soldier courses, plinths).

Items to be taken into account include:

**Fairfaced masonry**

**(a) level of bed joints**

± 8mm maximum deviation for walls 5m long (a pro rata tolerance is applicable for walls less than 5m long).

± 12mm maximum deviation for walls over 5m long.

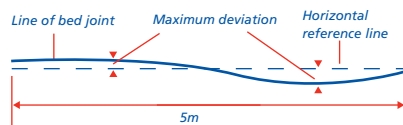

There should not be frequent variations in the level of the bed joints

**(b) thickness of bed joints**

The thickness of an individual bed joint should not vary from the average of any 8 successive joints by more than 5mm.

**Commentary**

- bricks and other materials vary in size and therefore some variation in the thickness of bed joints is likely.

**(c) straightness on plan**

±8mm maximum deviation in any length of wall up to 5m.

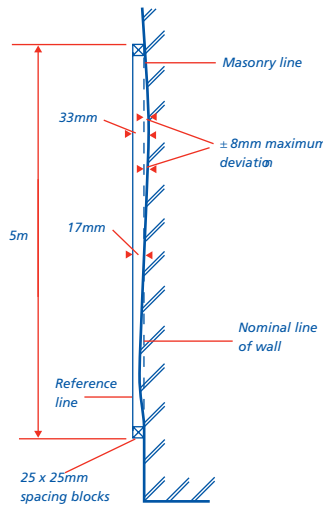

**Example:** Using 25mm wide spacing blocks, the masonry line should be between 17mm and 33mm from the reference line.

**Note:** Spacing block dimensions are a guide only To suit actual site conditions, final dimensions should ensure reference line is kept clear of the wall face.

**(d) perpend alignment in external walls**

Vertical alignment of perpend joints should not deviate significantly from the perpendicular.

**Commentary**

- because bricks do vary in length as a result of their manufacturing process, not all perpend joints will align. However, there should not be a cumulative displacement of the perpend joints in a wall.

**(e) plumb of wall**

Maximum 8mm out of plumb for walls up to 5m in height, limited to 8mm in a storey height (approx 2.5m).

Maximum 12mm out of plumb for walls over 5m in height, limited to 8mm in a storey height (approx 2.5m).

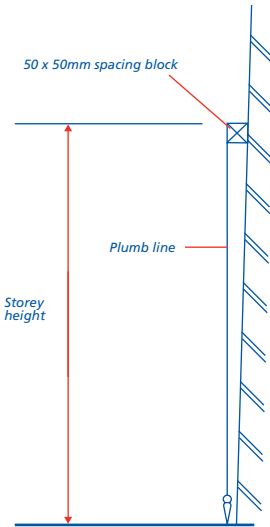
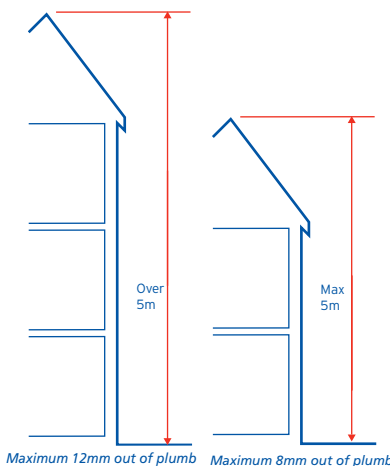

**Example:** Using 50mm wide spacing block, the plumb bob should be between 42mm and 58mm from the wall.

**Note:** Spacing block dimensions are a guide only To suit actual site conditions, final dimensions should ensure plumb line is kept clear of the wall face

**(f) straightness in section**

±8mm maximum deviation in any 2.5m height of wall.

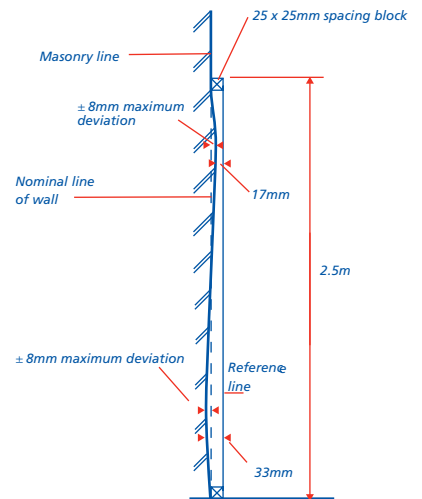

**Example:** Using 25mm wide spacing blocks, the masonry line should be between 17mm and 33mm from the reference line

**Note:** Spacing block dimensions are a guide only. To suit actual site conditions, final dimensions should ensure reference line is kept clear of the wall face

# 1.2 A consistent approach to finishes

## (g) straightness of external reveals

4mm maximum deviation.

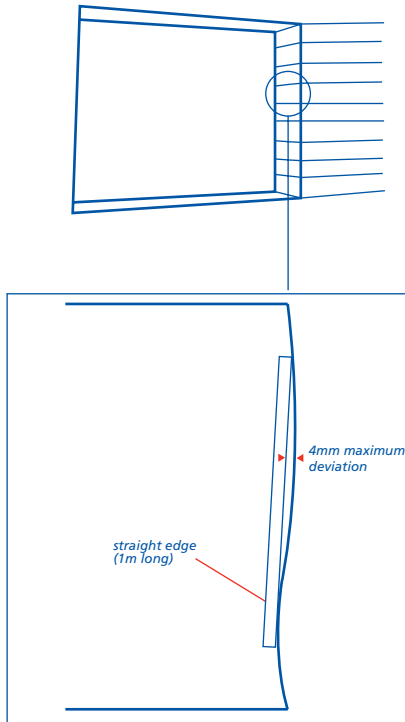

## Render

### (h) vertical and horizontal flatness

± 8mm maximum vertical and horizontal deviation from flatness in 5m (excluding features).

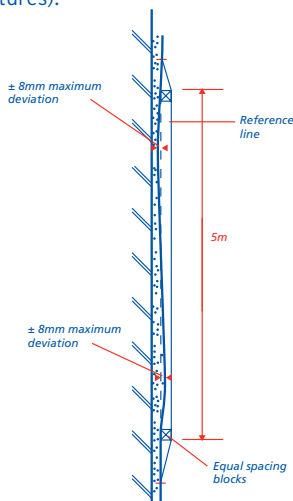

*Example:*  
Using 25mm wide spacing blocks, the render line should be between 17mm and 33mm from the reference line.

*Note:*  
Spacing block dimensions are a guide only. To suit actual site conditions, final dimensions should ensure the reference line is kept clear of the wall face.

### Commentary

- areas of render in close proximity to features (e.g. bell casts), are excluded from the tolerance

- flatness is measured in a similar way to straightness on plan and plumb of masonry.

## Curtain walling

### (i) line, level, plumb and plane

± 2mm maximum deviation in any one storey height or structural bay width and ± 5mm maximum deviation overall.

These tolerances apply unless otherwise specified in the design.

## Rainscreen cladding

### (j) line, level, plumb and plane

± 3mm maximum deviation in any one storey height or structural bay width.

These tolerances apply unless otherwise specified in the design.

## Brick slip cladding systems

### (k) vertical and horizontal flatness

± 8mm maximum vertical and horizontal deviation from flatness in 5m.

### (l) level of bed joints

± 8mm maximum deviation in the bed joints in a 5m length (a pro rata tolerance is applicable for walls less than 5m long).

## EXTERNAL WALLS - APPEARANCE

### 1.2 - S2 External walls shall have an appropriate appearance

Appearance should be considered for entire wall areas, panels, interfaces and the like and not for individual units. Consequently, the wall being considered should, where possible, be viewed in daylight from a distance of not less than 10m.

Some variation in colour and texture of external walls is inevitable and in certain cases is a feature.

Items to be taken into account include:

## Fairfaced masonry

### (a) appearance of fairfaced masonry

Fairfaced masonry should be reasonably uniform in texture, finish and colour. Excessive colour banding should not occur.

With certain walls, such as half brick walls, a fairfaced finish can only be achieved on one face. The other face should be left neat and tidy.

Mortar should be reasonably uniform in texture, finish and colour.

Facing brick units should not have significant cracks in them or other damage such as chips and marks greater than 15mm in diameter.

Commentary

- some mortar blemishes will occur on individual masonry units
- some variation will occur in the texture, finish and colour of mortar
- some variation will occur in the colour of individual masonry units and generally over the wall
- colour banding of fairfaced masonry should be avoided by mixing batches and consignments of bricks
- efflorescence occurs naturally in some types of masonry. It is not harmful and usually disappears over time
- some brick products have natural or design features which may be in excess of 15mm in diameter
- some minor shrinkage cracking may occur between masonry units (bricks and blocks) and mortar joints.

## Render

### (b) appearance of render

Rendering on walls should be reasonably consistent in texture, finish and colour.

### Commentary

- some hairline cracking and crazing is likely to occur in both traditional render and proprietary render systems. Such cracking and cracking should not impair the performance of the render
- crazing, which may occur in the render surface, should not be more than 0.2mm wide
- there may be some colour variation in appearance. This may be due to differences in suction of the background and orientation of the wall
- daywork joints, patching and other repairs may be visible but should not be unduly obtrusive.



## Curtain walling

### (c) appearance of curtain walling

Installation should ensure that curtain walling systems are within reasonable tolerances and appearance for the materials involved.

## Rainscreen cladding

### (d) appearance of rainscreen cladding

Installation should ensure that rainscreen cladding systems are within reasonable tolerances and appearance for the materials involved.

## Brick slip cladding systems

### (e) appearance of brick slip cladding systems

Installation should ensure that brick slip cladding systems are within reasonable tolerances and appearance for the materials involved.

## Timber cladding

### (f) appearance of timber cladding

Some variation in colour may occur in uncoated timber exposed to the weather.

The rate and extent of colour change will vary between species and can sometimes vary even within the same species.

#### Commentary

- the effects of normal weathering may cause certain uncoated timber, over time, to develop a silver/grey colour.

## Tile hanging

### (g) appearance of tile hanging

Panels of tile hanging should be reasonably uniform in appearance, particularly at abutments.

#### Commentary

- certain handmade tiles vary in size and may not be of a uniform appearance
- some variation in colour may occur in tiles.

## Cast stone sills

### (h) appearance of cast stone sills

Conspicuous surface abrasions and chips caused during installation should be removed in accordance with the manufacturer's recommendations which may include filling, polishing out, re-spraying or painting as appropriate.

#### Commentary

- cast stone is manufactured with natural products and colour variations are inevitable
- efflorescence, fungicidal growth and colour variation may occur due to orientation, shading and pollution.

## EXTERNAL WORKS

### 1.2 - S3 External works shall have appropriate finishes

Items to be taken into account include:

#### (a) drives, paths, decks, terraces and balconies - variations in surface finish

Variations in the surface should not exceed  $\pm 10\text{mm}$  maximum deviation from a 2m straightedge with equal offsets provided correct gradients have been used.

#### Commentary

- some minor variations in surface levels including scuffing and pitting may arise due to settlement, natural ground movement and car and light vehicle use. In gravel and other loose surfaces, displacement of stone etc. will occur
- localised falls into gulleys and channels are acceptable.

#### (b) drives, paths, decks, terraces and balconies - standing water

Surfaces should minimise the potential for standing water.

#### Commentary

- one hour after rain has stopped, areas of temporary standing water should not be deeper than 5mm or exceed  $1\text{m}^2$ . Temporary standing water is not permitted adjacent to entrance doors.

#### (c) covers to drainage systems

Covers to the drainage system should align with the adjacent ground or surface finish.

Covers to drainage channels should be set below the adjacent ground.

#### Commentary

- in hard landscaping, some settlement of the area immediately around the cover may occur. The difference in height between a cover and the adjacent hard surfaces should be set to allow for future settlement
- in soft landscaping, such as lawned areas, some settlement of the ground may occur.

## DOORS AND WINDOWS

### 1.2 - S4 Doors and windows shall be installed to appropriate tolerances

Items to be taken into account include:

#### (a) openings in walls (including external openings viewed from the inside)

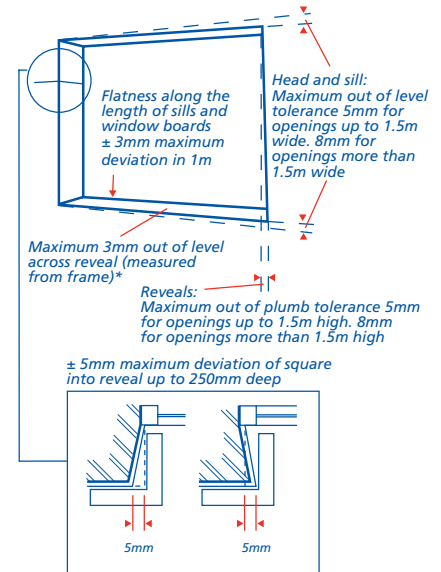

\*Tiled sills, for example, in bathrooms may be intentionally laid sloping away from the window

#### (b) gaps and distortion

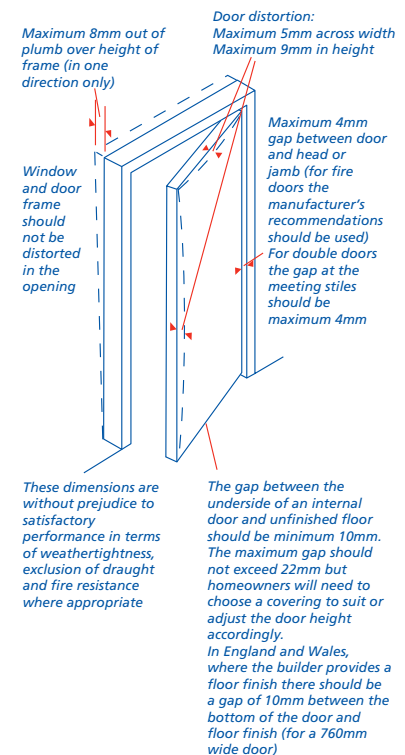

Window frames up to 1.5m in height  
- maximum 5mm out of plumb.  
Over 1.5m in height  
- maximum 8mm out of plumb.

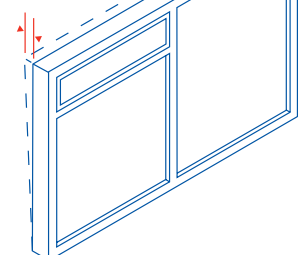

# 1.2 A consistent approach to finishes

## GLAZING

### 1.2 - S5 Glass shall be free of undue defects

The following are acceptable if they are neither obtrusive nor bunched:

- bubbles or blisters
- hairlines or blobs
- fine scratches not more than 25mm long
- minute particles.

The above does not apply within 6mm of the edge of the pane, where minor scratching is acceptable.

#### Commentary

- glass should be viewed in daylight from within the room and at least 2m from the panes (3m for toughened, laminated or coated glass) facing the glass.

## WALLS AND CEILINGS - TOLERANCES

### 1.2 - S6 Wall and ceiling finishes shall be built to appropriate tolerances

Items to be taken into account include:

#### Plastered and dry lined

##### (a) wall and ceiling surfaces

The deviation of board joints in walls and ceilings should not exceed 3mm when measured using a 450mm straightedge with equal offsets.

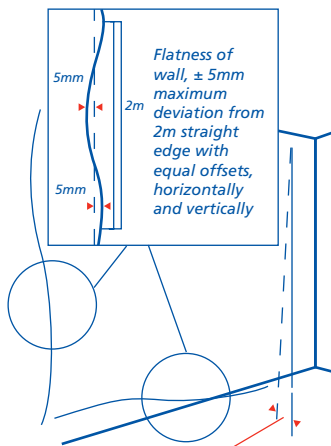

Plumb of wall finish:  
Maximum 8mm out of plumb in a storey height up to 2.5m - maximum 12mm out of plumb for a continuous wall height greater than 2.5m

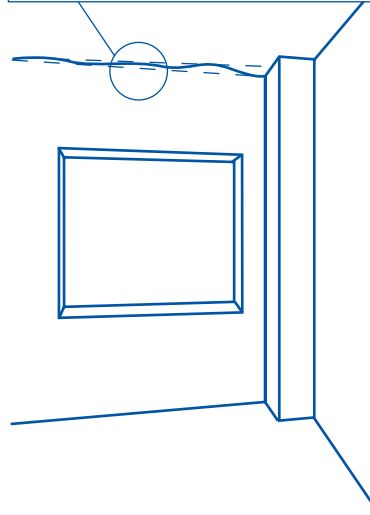
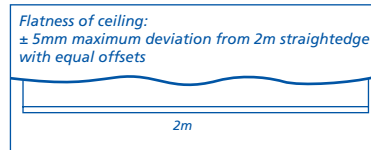
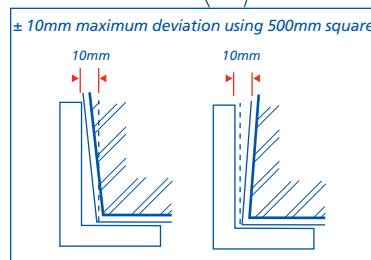
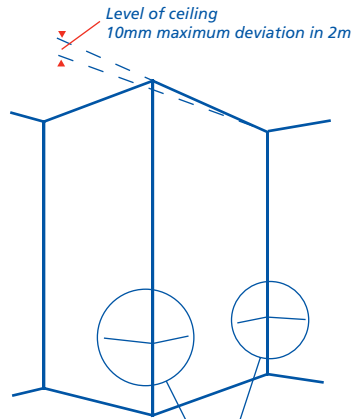

#### Duct casings

##### (b) squareness

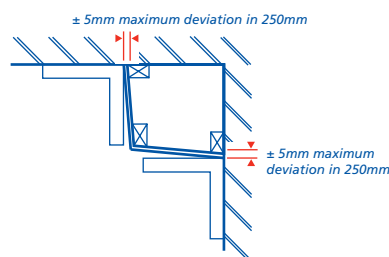

## Skirtings

##### (c) gaps

The gap between the floor finish (without coverings) and between the bottom of the skirting should not exceed 5mm.

#### Commentary

- the gap between the floor finish and the skirting may increase because of normal drying out, shrinkage and/or deflection, particularly in timber floors
- a gap may occur between the wall finish and skirting due to drying out, shrinkage and fixing position.

## WALLS AND CEILINGS - APPEARANCE

### 1.2 - S7 Wall and ceiling finishes shall have an appropriate appearance

Items to be taken into account include:

#### Plastered and dry lined

##### (a) appearance of wall and ceiling surfaces

Surfaces should be reasonably uniform although there may be minor textural differences around lights and other

fittings. There should be no visible gaps between fittings and the wall/ceiling (e.g. around switch plates).

In plastered walls and ceilings some tooling marks may be visible.

#### Commentary

- in general wall surfaces, some cracking (up to 2mm wide) is likely due to shrinkage and differential movement of materials
- at wall, floor and ceiling junctions where there are changes in the construction materials, small cracks (up to 2mm wide) may appear in the surface as a result of shrinkage and differential movement of materials
- jointing tape should be fully covered and not be obtrusive in the finished wall or ceiling surface
- small cracks may occur in wall finishes which pass across floors (e.g. in staircase walls)
- where stair strings abut a wall, a crack of up to 4mm may appear as a result of shrinkage of materials.

#### Duct casings

##### (b) appearance of duct casings

Duct casings, access covers and any associated framing should be neat and tidy and have an appropriate decorative finish.

#### Blockwork walls in garages

##### (c) appearance of blockwork walls in garages

Cracks (up to 2mm wide) in unplastered blockwork walls may be evident due to thermal movement and drying shrinkage.

## Skirtings

### (d) joints

Joints in skirtings are likely in long lengths of walls. Joints should present a continuous appearance when viewed from a distance of 2m in daylight. Some initial shrinkage of the skirting may already be evident at completion of the property.

#### Commentary

- gaps in skirtings may appear at joints and corners due to shrinkage.

## FLOORS

### 1.2 - S8 Floors shall be built to appropriate tolerances

Items to be taken into account include:

#### (a) level of floor

Maximum 4mm out of level per metre for floors up to 6m across, and maximum 25mm overall in any other case.

#### Commentary

- the effects of normal drying shrinkage on screeded floors may cause minor cracking
- timber floors and staircases naturally shrink as they dry. As this drying occurs, it may result in squeaking components as they move against each other. This is natural and to be expected, and cannot be totally eliminated.

#### (b) flatness of floor

± 5mm maximum deviation from a 2m straightedge with equal offsets.

#### (c) underfloor service ducts

Service ducts should be constructed so that the cover is level with the adjacent floor finish provided by the builder.

#### Commentary

- drying shrinkage of the floor may result in minor differences in level between the floor and duct cover. This may become evident with some types of thin floor coverings, and the choice of covering should take this into account.

## CERAMIC, CONCRETE, TERRAZZO AND SIMILAR TILE FINISHES

### 1.2 - S9 Tiling shall have an appropriate appearance

Items to be taken into account include:

#### (a) tile joints

Tile joints should be straight in alignment unless the tiles are, by design, irregular in shape.

The width of floor tile joints should not be less than 3mm, unless otherwise specified by the manufacturer.

The width of wall tile joints should not be less than 1mm.

This relieves any local stress that may occur.

Joints in floor tiles should generally not exceed the tile thickness, but wider joints, up to 10mm, may be necessary to accommodate dimensional irregularities in some tiles.

Where tiles have dimensional irregularities the joint dimensions should be "evened out" to maintain a regular appearance.

#### (b) overall variation in surface level of wall and floor tiles

± 3mm maximum deviation from a 2m straightedge with equal offsets.

#### (c) variations in surface level between adjacent wall or floor tiles

1mm for joints less than 6mm wide.  
2mm for joints more than 6mm wide.

## JOINT SEALANTS

### 1.2 - S10 Joint sealants shall have a neat and tidy appearance

Items to be taken into account include:

#### (a) appearance of joint

Sealants should be tooled to remove blisters and irregularities, and achieve a compact, smooth neat surface finish.

#### Commentary

- joints should normally be viewed from a distance of 2m (e.g. external window and door frames), but may be less depending on the location (e.g. showers and baths).

## OTHER SURFACES AND FINISHES

### 1.2 - S11 Other surfaces and finishes shall have an appropriate appearance

Items to be taken into account include:

#### (a) painted and varnished surfaces

Surfaces should be reasonably smooth and free from nail holes, cracks and splits. Open joints should be filled. Colour, texture and finish should be reasonably uniform.

#### Commentary

- surfaces should be viewed in daylight from a distance of 2m and not by shining artificial light on the surface. Wall lights or uplighters should be switched off
- painted and varnished surfaces should be free from conspicuous runs and prominent brush marks. There should be no bare or starved areas
- timber surfaces may show limited raised grain and the colour and texture may also vary
- drying shrinkage of timber may cause cracking of the paint finish, particularly where joints occur in plaster and woodwork
- where painted surfaces are touched-up, minor colour variations will occur
- external finishes will dull over time depending on a number of factors such as exposure to sunlight, rain and pollutants.

#### (b) knots in timber

Some exudation of resin from knots may occur and may cause discoloration of paintwork, both internally and externally.

#### Commentary

- because timber is a natural material some resin is likely to exude from knots even though modern primers contain a knotting compound to limit the effect.

#### (c) garage floors

Where garage floors have not been sealed, dusting may occur.

#### (d) socket, switch and other service outlets

Where there are two or more adjacent outlets they should be aligned horizontally.

## FITTED FURNITURE

### 1.2 - S12 Fitted furniture shall have an appropriate appearance

Items to be taken into account include:

#### (a) appearance

Doors and drawers of fitted furniture should be visually aligned vertically, horizontally and in plan, and operate as intended by the manufacturer.

Gaps between adjacent doors and/or drawers should be uniform.

There should be no significant difference in level at the intersection of adjacent worktops.

#### Commentary

- no dimensional tolerance has been set for gaps between adjacent doors and/or drawers or for their alignment because some variation will be necessary to take account of adjustments as part of the fitting process
- no dimensional tolerance has been set for the abutment of adjacent worktops because of the variety of materials available and because minor variations, even with manufactured products, are inevitable and small differences in height may be unavoidable
- fitted furniture should normally be viewed from a distance of 2m.

#### (b) scratches

Factory-finished components should not have conspicuous abrasions or scratches when viewed in daylight from a distance of 0.5m.

#### Commentary

- conspicuous surface abrasions caused during installation should be removed in accordance with the manufacturer's recommendations which may include filling, polishing out, re-spraying or painting as appropriate
- in rooms or areas where there is no daylight, scratches should be viewed in artificial light from fixed wall or ceiling outlets and not from portable equipment.

# 1.2 A consistent approach to finishes

## INDEX

<b>B</b>		<b>G</b>		<b>S</b>	
Bed joints	1	Garage floors	5	Scratches	5
Brick slip cladding systems	3	Garages, blockwork walls	4	Skirtings	5
<b>C</b>		Gaps and distortion	3	Sockets, switches and other service outlets	5
Cast stone sills	3	Glazing	4	Standing water	3
Ceramic, concrete, terrazzo and similar tile finishes	5	<b>J</b>		Straightness on plan	1
Covers to drainage system	3	Joint sealants	5	Straightness in section	2
Curtain walling	3	<b>K</b>		<b>T</b>	
<b>D</b>		Knots in timber	5	Thickness of bed joints	1
Doors and windows	3	<b>L</b>		Tile hanging	3
Drives, paths, decks, terraces and balconies	3	Level of bed joints	1	Tile joints	5
Duct casings	4	Level of floor	5	Timber cladding	3
<b>E</b>		<b>O</b>		<b>U</b>	
External reveals, straightness	2	Openings in walls	3	Underfloor service ducts	5
External walls, appearance	2	Other surfaces and finishes	5	<b>V</b>	
External walls, tolerance	1	<b>P</b>		Variations in surface finish	3, 5
External works	3	Painted and varnished surfaces	5	<b>W</b>	
<b>F</b>		Perpend alignment	1	Walls and ceilings, appearance	4
Fairfaced masonry	1, 2	Plumb of wall	1	Wall and ceiling surfaces	4
Fitted furniture	5	<b>R</b>		Walls and ceilings, tolerances	4
Flatness of floor	5	Rainscreen cladding	3	Windows and door openings	4
Floors	5	Rendering	2		

# Chapter 1.4

## Cold weather working

---



# 1.4 Cold weather working

## CONTENTS

### DESIGN

There are no specific Design implications

Clause Page

### MATERIALS

There are no specific Materials implications

### SITWORK

Sitework standards	S1	1
Temperature and weather conditions	S2	1
Protection of stored materials	S3	1
Concreting	S4	1
Masonry	S5	2
Rendering, plastering and screeding	S6	2
Use of admixtures	S7	2
Painting	S8	2

### INDEX

3

## SCOPE

This Chapter gives guidance on meeting the Technical Requirements and recommendations for cold weather working.



## SITWORK STANDARDS

- 1.4 - S1 All sitework shall:**  
**(a) meet the Technical Requirements**  
**(b) follow established good practice and workmanship**

Sitework that complies with the guidance below will be acceptable for cold weather working.

## TEMPERATURE AND WEATHER CONDITIONS

- 1.4 - S2 Allowance shall be made for cold weather conditions during construction**

Unless the precautions detailed in the following guidance are adopted, work should NOT proceed when the air temperature is below or likely to fall below 2°C. Frozen materials should not be used.

Items to be taken into account include:

**(a) temperature measurement**

A maximum/minimum thermometer should be available to indicate whether the temperature is falling or rising. The thermometer should be sited in the shade.

The temperature may drop rapidly after sunset.

**(b) weather and local topography**

### FORECASTS

Plan ahead and take account of weather forecasting services, by either stopping work or taking adequate precautions. The following services are available:

- pre-recorded weather forecasts on the WEATHERCALL telephone service
- weather forecasts specific to contractors' needs
- an assessment of time when suitable working conditions will prevail in a given area.

All these services are provided by the Meteorological Office.

### WIND CHILL

The Meteorological Office can advise on the wind chill factor. Strong winds can reduce the temperature of concrete and mortar more quickly than still conditions. Work is more likely to be affected by frost in windy freezing conditions.

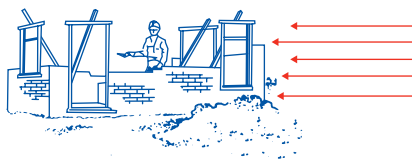

### TOPOGRAPHICAL FEATURES

High trees or adjacent buildings may provide permanent shade from low winter sun and slow down any temperature rise.



Frost hollows can occur where cold air is drawn into valleys.



## PROTECTION OF STORED MATERIALS

- 1.4 - S3 Stored materials shall be adequately protected against cold weather**

Items to be taken into account include:

**(a) overnight protection**

During cold weather, the use of covers will protect materials from overnight snow, ice and frost. They will also reduce the effects of longer term frosts, and permit an earlier resumption of work. Frozen materials should not be used.

Appropriate covers should be provided for bricks and blocks and for sand, aggregates and cement, to prevent them from becoming saturated, and damaged by frost.

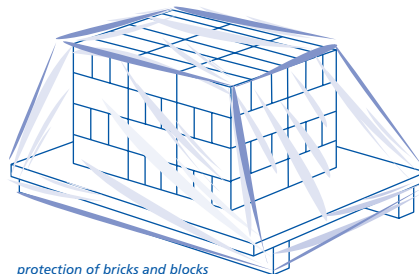

protection of bricks and blocks

**(b) longer cold periods**

If it is necessary to continue building during longer periods of cold weather, the use of heaters will protect aggregates and other materials from being frozen, and prevent frost damage to newly laid masonry.

## CONCRETING

- 1.4 - S4 Concrete shall not be placed in cold weather unless suitable precautions are taken**

Items to be taken into account include:

**(a) placing of foundation and oversite concrete**

Concrete should not be placed if the ground or oversite is frozen. Work built on frozen ground can be severely damaged by movement when thawing takes place.

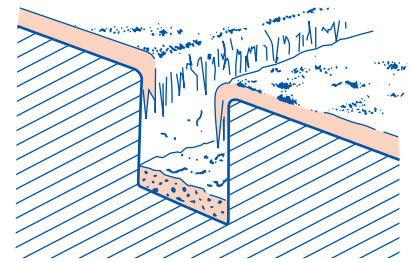

If work has to be carried out during long periods of cold weather, the whole work area should be covered, and heated if necessary, to maintain the temperature above freezing.

**(b) placing concrete other than in foundations or oversites**

All surfaces which can come into contact with fresh concrete, such as formwork, reinforcement, and other concrete surfaces should be free of snow, ice and frost. Special care is needed when small quantities of fresh concrete are placed against a large volume of hardened concrete at a lower temperature.

**(c) mixing concrete**

### READY-MIXED

The minimum temperature of concrete when delivered should be 5°C. This is a requirement of BS 5328.

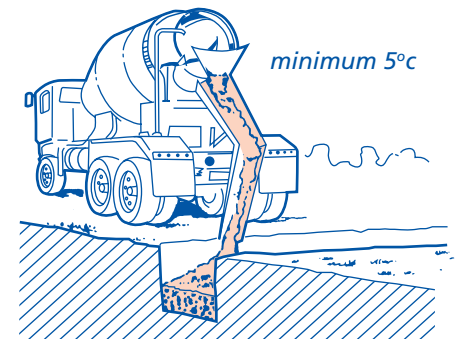

# 1.4 Cold weather working

## SITE-MIXED

If the air temperature drops to 2°C, concrete work should NOT proceed unless:

- the aggregate temperature is above 2°C, and the aggregate is free of frost and snow, and
- water for mixing is heated, but not in excess of 60°C, and
- the cement is not heated, and
- the cast concrete can be properly protected, taking account of the cross sectional area and location, and
- the ground into which the concrete is to be placed is not frozen.

Covers will not stop severe frost penetrating the aggregate. If work is to continue, it may be necessary to steam heat aggregate or use hot air blowers below covers.

Heated mixing water cannot be relied upon to thaw frozen aggregates. The amount of water in a mix is only a small proportion of the total mix volume. Very cold aggregate can absorb heat from water while remaining frozen.

### (d) curing

Curing periods may need to be extended at low temperatures. Advice on minimum periods is given in BS EN 13760 Table 4 Curing class 2. Table F1 gives the minimum curing period for Curing class 2.

50mm of insulation held down firmly at the edges will give protection to oversite concrete from slight overnight frosts. If very severe frosts are expected, insulation alone is inadequate, and heating should be provided.

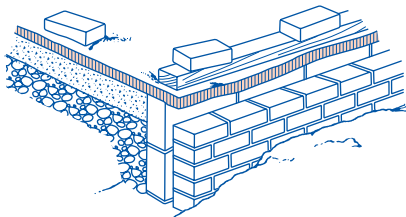

## MASONRY

**1.4 - S5 Masonry shall not be laid in cold weather unless suitable precautions are taken**

### MINIMUM TEMPERATURES

Materials which have been damaged by frost or are frozen should NOT be used.

When the temperature is below or likely to fall below 2°C, masonry should NOT be laid unless heating is provided. The temperature should be checked throughout the day on a maximum and minimum thermometer.

### PROTECTION

Newly laid masonry will need protection when the temperature is below or likely to fall below 2°C.

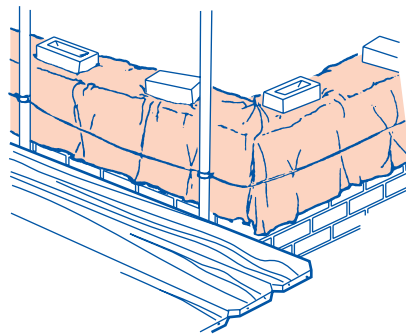

Polyethylene will provide weather protection and prevent work from becoming saturated.

An air gap between the masonry and the covers will enable new masonry to cure.

Additional insulation will be necessary at very low temperatures. If very severe frosts are expected, heaters would be required.

Protection against frost may be required for up to 6 days depending on the severity of the conditions.

## RENDERING, PLASTERING AND SCREEDING

**1.4 - S6 Rendering, plastering and screeding shall not be carried out in cold weather unless suitable precautions are taken**

### RENDERING

Rendering should NOT be carried out if:

- the temperature is below or likely to fall below 2°C, or
- backgrounds are saturated or frozen, or
- there is a possibility that new work will be subjected to frost before it has set.

### PLASTER AND SCREED

Plastering and screed laying should NOT be commenced unless the structure is free of frost. The temperature of the structure should be kept above freezing during the curing period.

It is important that heaters used for this purpose do not produce water vapour. While heaters are in use, the building should be ventilated to disperse moisture.

Because warm air rises, ground floors and walls near to floor level may be slow to respond to heating after a prolonged cold period. Warm air heaters should be placed in the room a day before plastering is to start, to allow sufficient time for the structure to warm up. Heating should continue for at least 48 hours after completion of work.

To avoid damage to screeds, plaster finishes and woodwork, heating should not be excessive.

## USE OF ADMIXTURES

**1.4 - S7 Admixtures shall be used correctly**

### PLASTICISERS AND ACCELERATORS

No admixture will prevent frost damage to immature concrete or mortar.

Plasticisers (which entrain air during mixing) can provide improved frost resistance to mature mortar and concrete.

Additives should only be used strictly in accordance with manufacturers' recommendations.

The use of accelerators may assist the mortar or concrete to set before temperatures fall.

### RETARDERS AND BONDING AGENTS

Retarding agents should NOT be used in cold weather as their use can seriously delay setting times of the cement. Bonding agents may be ineffective in cold weather.

### CALCIUM CHLORIDE

Calcium chloride and additives based on it do not prevent frost damage to mortars. These additives should NOT be used. They are also likely to have undesirable side effects.

## PAINTING

**1.4 - S8 Painting shall not be carried out when there is a risk of damage due to cold weather**

Painting should NOT be carried out:

- on surfaces that are affected by damp, frost or condensation
- where the air temperature is below or likely to fall below 2°C
- when condensation is likely to occur before paintwork is dry
- when snow or rain is likely before the paintwork is dry.

## INDEX

<b>A</b>		<b>M</b>		<b>T</b>	
Accelerators	2	Masonry	2	Temperature	1, 2
Admixtures	2	Materials	1	Topographical features	1
Aggregates	2	Minimum temperatures	2	<b>W</b>	
Air temperature	1	<b>O</b>		Water	2
<b>B</b>		Oversite concrete	1	Weather	1
Bonding agents	2	<b>P</b>		Wind chill	1
<b>C</b>		Painting	2		
Calcium chloride	2	Plastering	2		
Cast concrete	2	Plasticisers	2		
Cement	2	Protection	1, 2		
Concreting	1	<b>R</b>			
Curing	2	Ready-mixed concrete	1		
<b>F</b>		Rendering	2		
Forecasts	1	Retarding agents	2		
Foundations	1	<b>S</b>			
Frozen materials	1	Screeding	2		
<b>H</b>		Sitework standards	1		
Heaters	2	Site-mixed concrete	2		

---

# Part 2

## Materials

---

- 2.1 Concrete and its reinforcement
- 2.2 No longer allocated
- 2.3 Timber preservation  
(natural solid timber)



# Chapter 2.1

Concrete and its reinforcement

---



# 2.1 Concrete and its reinforcement

## CONTENTS

	Clause	Page
<b>DESIGN</b>		
Design standards	D1	1
Suitability of concrete	D2	1
Mixdesign	D3-D4	1
Reinforced concrete	D5-D6	2
Special types of concrete	D7	2
Admixtures	D8	2
Provision of information	D9-D10	2 -3
<b>MATERIALS</b>		
Materials standards	M1	3
Ready-mixed concrete	M2	3
Site-mixed concrete	M3	3
Reinforcement	M4	3
<b>SITWORK</b>		
Sitework standards	S1	3
Storage of materials	S2	3
Blinding concrete	S3	3
Formwork	S4	4
Reinforcement	S5-S6	4
Ready-mixed concrete	S7	4
On-site concrete mixing	S8	5
Testing	S9	5
Casting	S10	5
Curing	S11	5
<b>APPENDIX 2.1-A</b>		
Table 1 - General purpose concrete mixes		6
Site-mixed concrete:		
Table 2a - Mix proportion by weight		7
Table 2b - Mix proportion by volume		7
Table 2c - Slump classes		7
Table 3 - Exposure classes		7
Buried concrete in aggressive ground:		
Table 4a - Aggressive Chemical Environment for Concrete		8
Table 4b - Design guide for concrete elements in the ground		9
<b>INDEX</b>		10

## SCOPE

This Chapter gives guidance on meeting the Technical Requirements and recommendations for concrete mixes suitable for various locations in and around dwellings.



## DESIGN STANDARDS

### 2.1 - D1 Design shall meet the Technical Requirements

Design that follows the guidance below will be acceptable for concrete and its reinforcement.

## SUITABILITY OF CONCRETE

### 2.1 - D2 Concrete shall be suitable for its intended use

Concrete should be in accordance with relevant Building Regulations and other statutory requirements.

Items to be taken into account include:

#### (a) compliance with recognised design standards

Concrete design and specification should comply with the relevant British Standards. Mix design should take account of strength and durability and follow recognised standards and practices. Alternatively, mixes in accordance with the following guidance will be acceptable. (This applies to plain and reinforced concrete whether precast or in-situ.)

Tables 1, 2a and 2b of Appendix 2.1-A list uses of concrete, mix specifications and the mix proportions for Standardised Prescribed mixes as described in BS 8500 and BS EN 206. Table 3 of Appendix 2.1-A describes the exposure environments and examples where they may occur. Tables 4a and 4b in Appendix 2.1-A give guidance on selecting mixes for concrete elements in aggressive ground.

#### (b) choice of supplier of ready-mixed concrete

Ready-mixed concrete will only be acceptable from suppliers who operate a full quality control system which ensures that the concrete specified is delivered.

Suppliers of ready-mixed concrete who operate under the Quality Scheme for Ready-Mixed Concrete (QSRMC) or BSI Kitemark scheme are acceptable. Other suppliers of ready-mixed concrete may be accepted if their operations are to an equivalent quality standard acceptable to NHBC.

## MIX DESIGN

### 2.1 - D3 The concrete mix shall be specified correctly

Concrete mixes should be specified in accordance with BS 8500-1. Concrete mixes for particular end uses in housing applications may be selected from Table 1 in Appendix 2.1-A or Table A.7 of BS 8500-1 as either:

- Designated mix, which is supplied ready mixed, or

- Standardised prescribed mix for site mixing.

Equivalent Designated and Standardised Prescribed mixes are listed as suitable for particular end uses, for example:

unreinforced ground bearing garage floor slabs can use either:

- a GEN3 Designated mix, or
- a ST4 Standardised Prescribed mix.

### 2.1 - D4 Mix design shall ensure adequate durability

Items to be taken into account include:

#### (a) mix proportions

The various uses of concrete are shown in Table 1 in Appendix 2.1-A. Designated mixes should conform to Table 7 of BS 8500-2.

Standardised Prescribed mixes conform to either Table 2a or 2b in Appendix 2.1-A which are derived from Tables 10 and 12 respectively of BS 8500-2.

#### (b) sulfates and acids in ground or groundwater

Sulfates and other chemicals can cause expansion and disruption of concrete. Also, high acidity, for example in peat, or permeable soil with acidic groundwater, can cause damage to concrete. Where concrete is at risk from chemical attack from the ground or where the ground water is highly mobile the level of sulfate and other chemicals should be determined, in terms of the ACEC Class (Aggressive Chemical Environment for Concrete Class) in accordance with BRE Special Digest 1. For the higher ACEC classes specialist advice should be sought to determine the Design Chemical Class (DC Class) for the concrete element and any appropriate Additional Protective Measures (APM) which may be required. The mix specification should then be selected from Table A.7 of BS 8500-1.

For lower levels of ACEC Class (AC-1, AC-1s, AC-2, AC-2s and AC-2z) the mix specification may be selected using Tables 4a and 4b in Appendix 2.1-A.

#### (c) chlorides

Chlorides in concrete are likely to increase the risk of corrosion of embedded metal and can also reduce the resistance of concrete to chemical attack.

All concrete materials contain some chlorides. For concrete mixes, the limits on chloride content in fresh concrete are given in BS EN 206-1, Table 10.

Cured concrete may also be damaged by exposure to:

- chlorides in the ground
- sea spray, or
- products used for de-icing highways.

Where these conditions might occur, follow the guidance in relevant documents.

#### (d) aggregates

Aggregates should be of a grade which ensures adequate durability of the concrete.

Certain types of aggregate are shrinkable and require special precautions in mixing, as described in BRE Digest 357.

#### (e) alkali-silica reaction

Certain aggregates may be susceptible to attack from alkalis originating in the cement or other sources. The reaction causes expansion and subsequent cracking and disruption of the concrete.

The total alkali content of the concrete arising from all sources, calculated in accordance with BRE Digest 330 or Concrete Society Report 30 should not exceed 3.0kg/m<sup>3</sup>.

Where unfamiliar aggregate materials are used, special precautions may be required. Damage will normally only occur when all three of the following conditions exist:

- there is a high moisture level in the concrete, and
- there is an alkali source, and
- the aggregate contains an alkali reactive constituent.

#### (f) exposure to climate and atmosphere

Exposure classes related to environmental conditions are given in Table 3 of Appendix 2.1-A which corresponds to Table 4.1 of BS EN 1992-1-1. Table 1 of Appendix 2.1-A gives guidance on the strength class of concrete suitable for particular exposures for superstructure elements. Further guidance may be obtained from BS 8500-1.

Any concrete mix should be designed for the conditions expected:

- at the geographical location of the site, and
- at the location of the element in the structure.

The higher the concrete grade, the greater its resistance to:

- chemical attack, and
- mechanical wear.

Air entraining agents can effectively reduce the risk of frost damage to cured concrete.

#### (g) overall performance

In addition to the items listed above, durability of concrete is dependent upon:

- correct control of the water/cement ratio
- full compaction of the placed concrete
- good curing.

## REINFORCED CONCRETE

### 2.1 - D5 Reinforced concrete shall be designed to ensure adequate durability

Items to be taken into account include:

#### (a) loading

Reinforced concrete should be designed by an Engineer in accordance with Technical Requirement R5.

BS 8103-4 can be used for the design of suspended ground floors in houses, bungalows and garages.

#### (b) end restraint

Where the ends of slabs are cast monolithically with concrete members, surface cracking may develop over the supports. Reinforcement should therefore be provided in accordance with BS EN 1992-1-1.

#### (c) cover

For concrete not designed by an Engineer in accordance with Technical Requirement R5, the minimum cover for reinforcement should be:

Position of the concrete	Minimum cover [mm]
Incontact with the ground	75
Inexternal conditions	50
Castagainst a dpm on sand blinding	40
Againstadequate blinding concrete	40
Inprotected or internal conditions	25

#### (d) fire resistance

Concrete cover to reinforcement should be adequate not only for the exposure conditions but also, where necessary, to resist fire. Requirements for fire resistance are given in BS EN 1992-1-2.

Cover required by BS EN 1992-1-1 will normally provide up to one hour fire resistance for columns, simply supported beams and floors.

#### (e) blinding

Blinding concrete should be used only in the following situations:

- to protect the bottom of the trench/ excavation if there is a delay in pouring structural concrete
- to provide sufficient support to ensure that cover to reinforcement is maintained
- where the foundation has been slightly overdug
- where localised soft spots have been removed.

#### (f) carbonation

Carbonation is of concern in reinforced concrete because it reduces the corrosion protection given to the reinforcement by the concrete.

The effects of carbonation on concrete are to increase porosity and decrease alkalinity. When alkalinity is reduced below a certain level steel reinforcement can rust.

Carbonation cannot be prevented. The risk of reinforcement corroding can be reduced by providing as great a concrete cover as possible; and by ensuring that wet concrete is of good quality and properly compacted, so reducing the rate of carbonation.

### 2.1 - D6 Reinforcing steelwork shall be properly and clearly detailed, specified and scheduled

The steel specification should indicate the steel type, grade and size. Drawings and bending schedules should be prepared in accordance with BS 4466 and include all necessary dimensions for completion of the sitework.

## SPECIAL TYPES OF CONCRETE

### 2.1 - D7 Special types of concrete shall be appropriate for their use

Proprietary concrete, no-fines or lightweight concrete should be of a quality and density appropriate for their conditions of use.

If used for a structural purpose, the design should be in accordance with Technical Requirement R5, and the concrete mix design should be properly detailed.

If no-fines concrete is used, a render, cover coat or cladding should be applied to the finished structure, unless otherwise acceptable under Technical Requirement R3.

Proprietary methods of reinforcement, eg glass fibre, should be assessed in accordance with Technical Requirement R3.

## ADMIXTURES

### 2.1 - D8 Admixtures shall only be used to enhance the performance and durability of concrete

Items to be taken into account include:

- (a) improved workability
- (b) waterproofing
- (c) foaming agents
- (d) accelerated strength
- (e) retardation
- (f) chlorides

Admixtures should only be specified in full knowledge of how each one works, and any limitations on their use.

Admixtures are permitted in accordance with BS EN 206-1.

Where admixtures are permitted, they should be used strictly in accordance with the manufacturer's recommendations, including the stated dosage.

Air entraining agents increase the air void content and thereby the frost resistance of cured concrete, but do not prevent fresh concrete freezing in cold weather.

Admixtures should not be relied upon to prevent freezing.

Retarding agents can, in fact, increase the risk of frost damage.

Admixtures containing chloride should never be used in reinforced concrete.

## PROVISION OF INFORMATION

### 2.1 - D9 Designs and specifications shall be produced in a clearly understandable format and include all relevant information

Items to be taken into account include:

#### (a) ground aggressivity

Any ground aggressivity to concrete should be indicated as:

- Design Sulfate Class (DS Class)
- Aggressive Chemical Environment for Concrete Class (ACEC Class)

#### (b) strength and durability

Concrete performance depends as much on how the cured concrete element is produced as on the composition of the concrete.

The concrete specification should indicate clearly any requirements which are of specific importance, such as:

- strength
- maximum free water/cement ratio and/ or minimum cement content
- consistence class (e.g slump)
- air content (if required)
- aggregate size
- colour.

#### (c) mix design and Additional Protective Measures (APM)

Drawings and specifications for concrete work should include:

- specification of mix designs (concrete strength class)
- details of any Additional Protective Measures.

#### (d) reinforcement and movement joints

Drawings and specifications for concrete work should include:

- cover to reinforcement
- reinforcement, plans, sections and bending schedules
- reinforcement details at supporting edges
- camber in beams and slabs, where appropriate
- reinforcement around openings
- movement joints.

**(e) formwork**

Information should be included on:

- formwork materials and features
- joints
- mould release agents
- holes for services.

Concrete which is to be left untouched or with minimum finishing may require detailed formwork drawings indicating the position and detail of joints between shutters, corners and other critical junctions.

**(f) finish**

Information should include details of final finishing treatment.

**(g) testing**

Information should include:

- number and frequency of samples to be taken
- test laboratory arrangements
- recording of results.

**(h) curing and protection**

Information should include:

- requirements for curing and striking formwork
- minimum period that should elapse before striking/removal of formwork
- minimum periods of curing
- minimum periods of protection.

**2.1 - D10 All relevant information shall be distributed to appropriate personnel**

Ensure that design and specification information is issued to site supervisors and relevant specialist subcontractors and/or suppliers.

**MATERIALS STANDARDS****2.1 - M1 All materials shall:**

- (a) meet the Technical Requirements**
- (b) take account of the design**

Materials that comply with the design and the guidance below will be acceptable for concrete and its reinforcement.

Materials for concrete and its reinforcement should comply with all relevant standards, including those listed below. Where no standard exists, Technical Requirement R3 applies (see Chapter 1.1 'Introduction to the Standards and Technical Requirements').

References to British Standards and Codes of Practice include those made under the Construction Products Directive (89/106/EEC) and, in particular, appropriate European Technical Specifications approved by a European Committee for Standardisation (CEN).

**READY-MIXED CONCRETE****2.1 - M2 Ready-mixed concrete shall be in accordance with the design and shall be chosen to ensure sufficient strength and durability**

Ready-mixed concrete should be ordered to a detailed specification conforming to BS 8500 and BS EN 206-1.

When Designated mixes are used, the ready-mix supplier will only require the mix designation, and consistence class

**SITE-MIXED CONCRETE****2.1 - M3 Materials for site-mixed concrete shall be in accordance with the design and shall be chosen to ensure sufficient strength and durability**

Items to be taken into account include:

**(a) cement or cementitious material**

Cement and combination and combination types should be as:

Table 1 of BS 8500-2 and should conform to the Standards quoted therein and in the case of combinations to Annex A of BS 8500-2.

**(b) aggregates**

Aggregates should comply with:

BS EN 12620 Aggregates for concrete.

Aggregates should consist of any types of coarse and/or fine aggregate as specified. Aggregates supplied as a mixture of different sizes should be proportioned to ensure a reasonable consistency.

Certain types of aggregate are shrinkable and require special precautions in mixing as described in BRE Digest 357.

Certain types of aggregate may be susceptible to alkali attack or excessive moisture movement. Unfamiliar materials should be checked and precautions taken, where necessary. Aggregate Carbon Range (ACR) should not exceed the specified limits if required for use in concrete subject to aggressive sulfate ground conditions.

Proprietary aggregates should only be specified where they have been assessed in accordance with Technical Requirement R3.

**(c) water**

Water from the mains is acceptable. Water from other sources should meet: BS EN 1008 Mixing water for concrete.

**(d) admixtures**

Admixtures, other than air-entraining admixtures, should comply with: BS EN 934-2 Admixtures for concrete mortar and grout - Concrete admixtures - Definitions, requirements, conformity, marking and labelling.

Air entraining admixtures should not be used in Standardized Prescribed concrete mixes.

**REINFORCEMENT****2.1 - M4 Reinforcement shall be in accordance with the design**

Reinforcement should comply with:

BS4449	Specification for carbon steel bars for the reinforcement of concrete
BS4482	Specification for cold reduced steel wire for the reinforcement of concrete
BS4483	Specification for steel fabric for the reinforcement of concrete
BS6744	Specification for austenitic stainless steel bars for the reinforcement of concrete.

**SITWORK STANDARDS****2.1 - S1 All sitework shall:**

- (a) meet the Technical Requirements**
- (b) take account of the design**
- (c) follow established good practice and workmanship**

Sitework that complies with the design and the guidance below will be acceptable for the use of concrete and its reinforcement.

Adequate concrete performance depends as much on how the cured concrete element is produced as on the composition of the concrete.

**STORAGE OF MATERIALS****2.1 - S2 Materials shall be properly stored to avoid impairing the performance of the finished concrete**

Where materials need to be stored, the following

precautions should be taken:

- store cement in a dry place
- store each type of cement separately
- follow the cement manufacturer's recommendations on maximum storage time
- store different sizes of aggregate in separate bays
- keep sand and aggregate clean
- keep sand and aggregate dry - where this is not possible, allowance must be made in the concrete batching for moisture in the sand and aggregate.

For precautions during cold weather, reference should be made to Chapter 1.4 'Cold weather working'.

**BLINDING CONCRETE****2.1 - S3 Blinding concrete shall be used, where required, to aid construction**

Blinding concrete should only be used in the following situations:

# 2.1

## Concrete and its reinforcement

2.1

- to protect the bottom of the trench/ excavation if there is a delay in pouring structural concrete
- to provide sufficient support to ensure cover to reinforcement is maintained
- where the foundation has been slightly overdug
- where localised soft spots have been removed.

### FORMWORK

#### 2.1 - S4 Formwork shall be structurally adequate and constructed in a workmanlike manner

Items to be taken into account include:

##### (a) setting out

Where formwork is necessary, it should be set out in relation to relevant reference lines and benchmarks. Accuracy is essential to ensure that the cover to the reinforcement is as specified.

##### (b) support of working loads

The formwork and its supports should be rigid enough to maintain the correct position and to withstand all extra loads and accidental knocks likely to occur when concrete is placed and compacted.

Wedges, inserts and boxes should be firmly secured to avoid displacement during vibration.

##### (c) finish

For concrete which is to be left untreated or with minimum finishing, the tightness of formwork joints is particularly important to avoid grout loss and resulting ragged edges.

Joints between shutters should be constructed for easy stripping.

Any holes for bolts or spacers should be drilled with care to avoid disfiguring or splintering the formwork surface and giving a poor finish.

##### (d) striking

Formwork should be capable of being struck without damage to the concrete.

Formwork should be dismantled without shock, disturbance or damage to the concrete. Support for loadbearing elements should not be removed until the concrete has achieved sufficient strength, as detailed by the designer.

Props under suspended floors or beams should be released from the centre, outwards to avoid overloading.

### REINFORCEMENT

#### 2.1 - S5 All reinforcement shall be in accordance with the design

Items to be taken into account include:

##### (a) condition of reinforcement

Check that reinforcing bars are clean, and free from loose rust and contaminants

(especially shutter releasing agents and oils) before, during and after placement.

##### (b) shape of bars

Site bending should be carried out with the proper machinery for the job, whether hand-operated or powered.

##### (c) placing of bars

Bars should be bent and placed as shown on the drawings.

Reinforcement should be laid so that the main reinforcing bars are parallel to the span or as detailed in the design.

Slab reinforcement should be located near the bottom of the slab, with the main reinforcing bars usually placed first and the secondary bars on top. For beams, the main reinforcing bars should be placed inside the links.

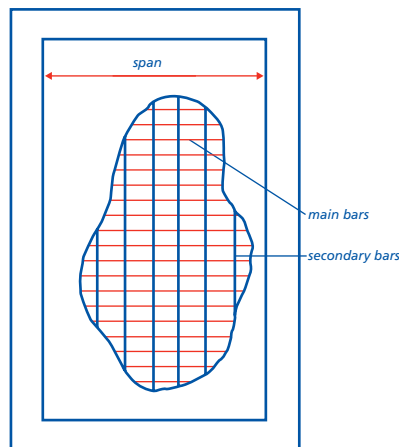

##### (d) lapping bars and mesh

Reinforcing bars or mesh should always be lapped in accordance with their size and type, as indicated by the designer, to ensure that the loading is fully transferred across the lap. Any additional laps require the designer's approval.

##### (e) cover for bars

Particular attention should be given to maintaining adequate cover for the reinforcement, especially for concrete in exposed positions or in the ground. Check that the cover is adequate for stirrups as well as for the main bars, and that no ties or clips protrude into the cover.

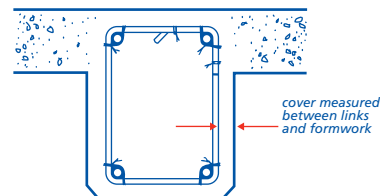

##### (f) support of reinforcement

Cover spacers should be made of concrete (eg broken concrete paving slabs) or ready made of steel or plastic. Concrete cover spacers should be not more than 50 x 50mm.

Supports should be placed not more than one metre apart or closer where necessary.

Spacers for parallel bars should be staggered to avoid creating a plane of weakness in the concrete.

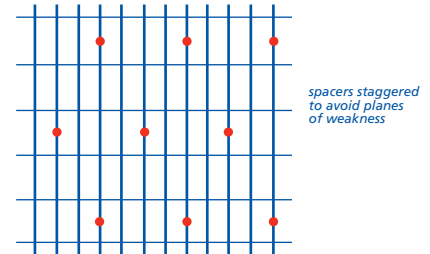

Supports for top steel should be chairs (or other proprietary products).

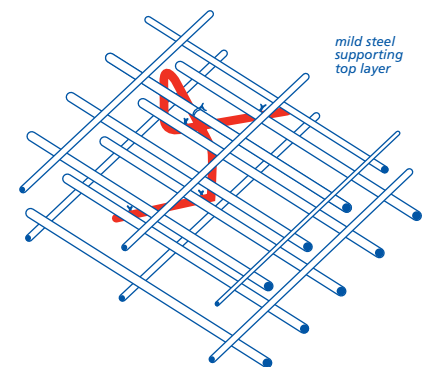

For details of reinforcement for suspended ground floor slabs, reference should be made to Chapter 5.2 'Suspended ground floors' (Design).

#### 2.1 - S6 All installations and final preparations shall be completed before concreting starts

Before concreting starts, all services, ducts, inserts, etc to be embedded in the concrete should be installed and, where appropriate, tested.

All inserts, box-outs, cast-in fixings, etc should be checked for correct positioning and secured.

The formwork should be cleaned out and checked for fallen debris, especially nails and wire clippings. The completed reinforcement should be checked and, where necessary, approved by the designer or his representative.

### READY-MIXED CONCRETE

#### 2.1 - S7 Ready-mixed concrete shall be ordered to ensure it achieves the required design strength and durability

When ordering ready-mixed concrete all requirements according to the design, including reference to Appendix 2.1-A, should be specified.



The concrete should be a GEN mix, FND mix or RC mix ordered in accordance with Appendix 2.1-A Tables 1 and 4b.

Check the delivery ticket to ensure that the concrete meets the requirements given in the design.

## ON-SITE CONCRETE MIXING

### 2.1 - S8 Concrete shall be mixed to achieve the required design strength and durability

Items to be taken into account include:

#### (a) mixing methods

Except for very small quantities, a mechanical mixer should be used. If hand mixing, add an extra 10% of cement to the quantities shown in Tables 2a and 2b in Appendix 2.1-A.

#### (b) admixtures

Admixtures should be used only where permitted in the specification. Dosages should be strictly in accordance with the manufacturer's instructions and should be tested in trial mixes, where necessary. Admixtures should, wherever possible, be added to the mix water to ensure complete dispersal.

Do not overdose concrete with admixtures - use the correct dosage.

Plasticizers can improve concrete cohesion and the bond with reinforcement.

Air entraining agents increase the air void content of the cured concrete and can help produce a more frost resistant surface. They are recommended for paths, drives and pavements which are likely to be exposed to freezing conditions.

Accelerators produce early setting of the concrete. No admixture should be relied upon as an anti-freeze for fresh concrete. For details about concreting at low temperatures, reference should be made to Chapter 1.4 'Cold weather working'.

Admixtures containing chlorides can cause metal corrosion and should never be used in reinforced concrete.

## TESTING

### 2.1 - S9 Testing, where required, shall be carried out to the full satisfaction of NHBC

Where testing is necessary to ensure that concrete is to the strength required by the design, ie with Designed mixes, UKAS approved laboratories should be used.

Concrete test cubes should be prepared as requested by the Engineer. These should be marked, cured and stored safely until testing. Tests should be carried out in accordance with BS EN 12390.

Proof of testing with reports and certificates, should be kept for later

reference. Proof of testing, with allied documentation, should be made available to NHBC upon request. A ready-mix concrete supplier should take test cubes, as required, for his quality assurance procedures.

## CASTING

### 2.1 - S10 Concrete shall be cast so as to achieve the required design strength and durability

Items to be taken into account include:

#### (a) transportation

Concrete should be deposited as close as possible to its final location. Transportation on site should be as fast and efficient as possible in order to avoid segregation and to ensure full compaction of the placed concrete.

#### (b) low temperatures

The temperature of the concrete at the point of use should not be less than 5°C (41°F).

Fresh concrete is susceptible to frost damage. Freezing can cause internal damage that is not immediately obvious. During cold weather, either stop working or follow the recommendations given in Chapter 1.4 'Cold weather working'.

#### (c) placing

Site-mixed concrete should be placed within 30 minutes, and ready-mixed concrete within 2 hours, of water being added to the cement.

Additional water should not be added to ready-mixed concrete unless under the supervision and approval of the supplier. Concrete should not be placed in or under water, unless it has been specially designed for that use.

Concreting should, wherever possible, be carried out in one operation, taking account of:

- weather conditions,
- available daylight, and
- time to allow for surface finishing.

#### (d) avoiding construction joints

Concrete cast in one operation (ie without construction joints) should not be greater than the following, and should always be as square in shape as possible:

- reinforced concrete 60m<sup>2</sup>
- unreinforced concrete 16m<sup>2</sup>.

Sufficient concrete should be mixed/ordered, so that it can be placed in a continuous process. Construction joints should be formed only if unavoidable and then in consultation with the Engineer. Before work continues beyond the joint, all shuttering should be removed.

#### (e) joints in foundations

Joints should not be positioned next to a return in the foundation.

#### (f) compaction

Concrete should be consolidated according to the design and specification requirements.

Reinforced concrete should be fully compacted using poker vibration unless the design states otherwise. Poker vibration should be carried out by experienced operators to ensure complete coverage and avoid honeycombing.

Vibrating beams or hand tamping may be used to consolidate slabs up to 150mm thick, unless the design details otherwise.

Excessive use of vibration can cause segregation and prevent concrete reaching an adequate strength.

#### (g) protection after placing

Freshly poured concrete should be kept moist by covering as soon as the surface is hard enough to resist damage. This is particularly important in hot, windy or cold weather to prevent the surface drying out too rapidly or freezing. Damp hessian, damp sharp sand or an impervious sheet (such as polyethylene) are acceptable as surface coverings. An alternative is to apply a curing agent to the surface of concrete.

## CURING

### 2.1 - S11 Concrete shall be adequately cured to achieve full design strength

Check the design to see if there are any special requirements for curing concrete.

No load should be allowed on the work until the concrete has cured sufficiently.

It is recommended that plain unreinforced concrete made with ordinary Portland cement is left for at least 4 days to cure. It is possible to proceed with substructure masonry above strip or trench fill foundations on unreinforced ordinary Portland cement concrete at an early stage, provided care is taken to protect the surface from damage.

Reinforced concrete, or concrete containing cement replacements, such as PFA, will require a longer curing period. This will normally be 7 days and the concrete structure should not be loaded during this period.

Any curing agents should comply with Technical Requirement R3 and should be applied strictly in accordance with the manufacturer's instructions. Curing agents should never be used on floors which are to receive either a topping or a screed, as it could affect the future bond.

Curing periods may be extended at low temperatures, as described in Chapter 1.4 'Cold weather working'.

# 2.1 Concrete and its reinforcement

## APPENDIX 2.1-A

**Table 1 - General purpose concrete mixes - minimum concrete specification (non-hazardous conditions)**

Use	BS 8500 and BS EN 206-1		
	Ready-mixed concrete (Designated mix)	Site-mixed concrete (Standardised Prescribed mix)	Consistence class
<b>Substructure and ground floors</b> <ul style="list-style-type: none"> <li>rough blinding (non-structural)</li> <li>infill</li> <li>unreinforced oversite concrete below timber floors</li> </ul>	GEN1	ST2	S3
<ul style="list-style-type: none"> <li>structural blinding and overbreak</li> <li>strip foundations</li> <li>trench fill</li> <li>other mass concrete foundations</li> <li>fill to wall cavity</li> <li>solid filling under steps</li> </ul>	GEN1	ST2	S3/S4 <sup>1</sup>
<ul style="list-style-type: none"> <li>house floors not designed as suspended and not reinforced                             <ul style="list-style-type: none"> <li>permanent finish to be added eg screed or floating floor</li> <li>no permanent finish to be added eg carpet</li> </ul> </li> </ul>	GEN1	ST2	S2
	GEN2	ST3	S2
<ul style="list-style-type: none"> <li>garage floors not designed as suspended and not reinforced</li> </ul>	GEN3	ST4	S2
<ul style="list-style-type: none"> <li>house and garage ground floor slabs                             <ul style="list-style-type: none"> <li>fully or nominally reinforced, either ground bearing, suspended or over sub-floor voids</li> </ul> </li> </ul>	RC35	ST5 <sup>2</sup>	S2
<b>Superstructure</b> <ul style="list-style-type: none"> <li>general reinforced concrete exposure class<sup>3</sup> to BS 8500-1                             <ul style="list-style-type: none"> <li>nominal cover to reinforcement of 35mm (which is the minimum cover of 25mm plus an allowance in design for deviation of 10mm)</li> <li>XC1 (dry) and XC2 (wet, rarely dry)</li> <li>XC3 (moderate humidity), XC4 (cyclic wet and dry) and XF1 (freeze/thaw attack and no de-icing agent)</li> <li>nominal cover to reinforcement of 40mm (which is the minimum cover of 30mm plus an allowance in design for deviation of 10mm)</li> <li>Any exposure class (XC1-4 and XF1)</li> </ul> </li> </ul>	RC30	<sup>4</sup>	S2
	RC40	-	S2
	RC35	<sup>5</sup>	S2
<b>In-situ external concrete</b> <ul style="list-style-type: none"> <li>drives and paths</li> <li>foundations for precast concrete paving slabs</li> </ul>	PAV1 GEN1	ST5 <sup>6</sup> ST1	S2 S1

### Notes

- Consistence class S3 should be used for strip foundation concrete and Consistence class S4 should be used for trench fill foundation concrete.
- ST4 mix for house and garage floors may only be used in conjunction with Chapter 5.2 'Suspended ground floors'. In all other cases the designated mix should be used.
- Exposure classes (XC1-4 and XF1) are defined in BS 8500-1 Table A.1.
- In this situation an ST4 mix may be used but only for small quantities of concrete. In all other cases the appropriate designated mix should be used.
- In this situation an ST5 mix may be used but only for small quantities of concrete. In all other cases the appropriate designated mix should be used.
- Not suitable in areas of severe exposure to frost attack (see Chapter 6.1 Appendix B). This is equivalent to Exposure Class XC4 above.

## Tables 2a, 2b and 2c - Site-mixed concrete for Standardised Prescribed Mixes

**Table 2a - Mix proportions by weight**

This table applies to cement strength class 32.5 and 20mm maximum aggregate size. Where cement strength class 42.5 or higher is used the cement weight should be decreased by 10%.

Standardised Prescribed Mix	Consistence Class (see Table 2c)	Cement (kg)	Fine aggregate (kg)	Coarse aggregate (kg)
ST1	S1	230	770	1155
ST2	S2	265	760	1135
ST2	S3	285	735	1105
ST2	S4	300	815	990
ST3	S2	295	745	1120
ST4	S2	330	735*	1100
ST5	S2	375	720*	1080

**Table 2b - Mix proportions by volume**

This table applies to 20mm maximum aggregate size

Cement strength class	Standardised Prescribed Mix	Consistence Class (see Table 2c)	Number of (25 kg) bags of cement	Fine aggregate (litres)	Coarse aggregate (litres)
32.5	ST1	S1	1	60	85
	ST2	S2	1	50	75
	ST2	S3	1	45	70
	ST2	S4	1	50	60
	ST3	S2	1	45	65
42.5 or higher	ST1	S1	1	65	95
	ST2	S2	1	55	80
	ST2	S3	1	50	75
	ST2	S4	1	55	65
	ST3	S2	1	50	75

**Table 2c - Consistence classes**

Consistence class	Consistence (slump) in mm
S1	10 to 40
S2	50 to 90
S3	100 to 150
S4	160 to 210

### Notes

\* Fine aggregate grading to be grades CP or MP only of BS EN 12620.

## Table 3 - Exposure classes

Exposure class	Environment	Exposure conditions
XC1	Dry or permanently wet	Concrete inside buildings with low air humidity Concrete permanently submerged in water
XC2	Wet, rarely dry	Concrete surfaces subject to long-term water contact Many foundations
XC3	Moderate humidity	Concrete inside buildings with moderate or high air humidity External concrete sheltered from rain
XC4	Cyclic wet and dry	Concrete surfaces subject to water contact, not within exposure class XC2
XF1	Moderate water saturation, without de-icing agent	Vertical concrete surfaces exposed to rain and freezing

### Notes

This table is based on Table 1 of BS EN 206-1

# 2.1 Concrete and its reinforcement

## Tables 4a and 4b - Buried concrete in aggressive ground

Tables 4a and 4b are based on extracts from BS 8500-1 & 2 and BRE Special Digest 1. They cover the lower range of chemical aggressiveness. For concrete exposed to more aggressive conditions, specialist advice should be sought. For the purposes of Chapter 2.1 the following terminology is used. Other related terms, which might be encountered in specialist reports, are described in BRE Special Digest 1.

**Table 4a - Aggressive Chemical Environment for Concrete (ACEC) site classification<sup>(1)</sup>**

This table applies to concrete exposed to ground with a pH value greater than 2.5

Sulfate and magnesium						Natural soil		Brownfield <sup>(3)</sup>		ACEC Class for site
Design Sulfate Class for site	2:1 Water/soil extract		Groundwater		Total Potential Sulfate <sup>(2)</sup>	Static water	Mobile water	Static water	Mobile water	
1	2	3	4	5	6	7	8	9	10	11
	SO <sub>4</sub>	Mg	SO <sub>4</sub>	Mg	SO <sub>4</sub>	pH	pH	pH <sup>(5)</sup>	pH <sup>(5)</sup>	
	mg/l	mg/l	mg/l	mg/l	%					
DS-1	<500	All Mg values	<400	All Mg values	<0.24	>2.5		>2.5		AC-1s
							>5.5 <sup>(6)</sup>		>6.5	AC-1
							2.5 -5.5		5.5-6.5	AC-2z
									4.5-5.5	AC-3z
									2.5 -4.5	AC-4z
DS-2	500-1500	All Mg values	400-1400	All Mg values	0.24-0.6	>3.5		>5.5		AC-1s
							>5.5		>6.5	AC-2
						2.5-3.5		2.5-5.5		AC-2s
							2.5-5.5		5.5-6.5	AC-3z
									4.5-5.5	AC-4z
									<4.5	AC-5z

### Notes

- For concrete quality and APM for ACEC Classes above AC-2z follow specialist advice. For the full list of ACEC Classes refer to Table A.2 of BS 8500-1 or BRE Special Digest Part C Table C1 for natural ground locations and Table C2 for brownfield locations.
- Applies only to sites where concrete will be exposed to sulfate ions (SO<sub>4</sub>) which may result from the oxidation of sulphides such as pyrite, following ground disturbance.
- Applies to locations on sites that comprise either undisturbed ground that is in its natural state or clean fill derived from such ground.
- 'Brownfield' is defined as sites which may contain chemical residues remaining from previous industrial use or from imported wastes.
- An additional account is taken of hydrochloric and nitric acids by adjustment to sulfate content.
- For flowing water that is potentially aggressive to concrete owing to high purity or an aggressive carbon dioxide level greater than 15 mg/l, increase the ACEC Class to AC-2z.

### Explanation of suffix symbols to ACEC Class number

- Suffix **s** indicates that, as the water has been classified as Static, no Additional Protective Measures are generally necessary.
- Concrete placed in ACEC Classes which include the suffix **z** have primarily to resist acid conditions and may be made with any of the cements or combinations listed in Table D2 of BRE Special Digest 1.

This table is based on Tables C1 and C2 of BRE Special Digest 1.



**Table 4b - Design guide for concrete elements in the ground**

Concrete element	ACEC Class <sup>(1)</sup>	Designated mix
Stripor trenchfill foundation, raft foundation, pile <sup>(3)</sup> and ground beams	AC-1,AC1s	AsTable 1
	AC-2,AC2s	FND2 <sup>(2)</sup>
	AC-2z	FND2z <sup>(2)</sup>

**Notes**

- 1 For all other ACEC Classes refer to BS 8500-1 Table A.4 or follow specialist advice.
- 2 Portland limestone cement may only be used if the Design Sulfate Class (see Table 4a) of the site does not exceed DS-1.
- 3 Applies to cast-in-situ piles only and for other types of pile refer to BRE Special Digest 1 or follow specialist advice.

**Glossary of terms**

**Aggressive Chemical Environment for Concrete Classification (ACEC Class)** - A new system for the classification of aggressive ground conditions that are derived from Design Sulfate Class. It takes into account the site (natural or brownfield) and the mobility and pH of groundwater. Brownfield, 'Mobile' water and low pH (acidic) conditions, may have adverse effects on buried concrete and hence result in a more severe ACEC Class.

**Additional Protective Measures (APM)** - These are defined as the extra measures that could be taken to protect concrete where the basic concrete specification might not give adequate resistance to chemical attack.

**Design Chemical Class (DC Class)** - This defines the qualities of concrete that are required to resist chemical attack. The DC Class is derived from the ACEC Class of the ground and other factors including the type of concrete element and its required structural performance.

**Design Sulfate Class (DS Class)** - It is a site classification based on the determined sulfate (including Potential sulfate) contents of the ground and/or groundwater. It is also dependent on the type of site, presence or absence of magnesium ions, pyrite and for pH less than 5.5 chloride and nitrate ions. Five levels of classification are given that are equivalent to those given in BRE Digest 363 (now superseded).

**Enhanced concrete quality** - An incremental step in concrete quality that could be used as an Additional Protective Measure (APM). Each increment in concrete quality is counted as an extra APM.

**Mobile groundwater** - Sites where water is free to flow into an excavation to give a standing water level are affected by mobile ground water. The threshold ground permeability is greater than  $10^{-6}$  m/s (i.e. 86 mm/day).

**Static groundwater** - The sites where the free flow of water is confined due to either permanently dry condition or the soil is relatively impermeable, of permeability less than  $10^{-6}$  m/s.

**Total Potential Sulfate (TPS)** - The total potential sulfate content is the result of the combination of sulfates already present in the ground and that which may be added due to the oxidation of pyrite in the ground.

## INDEX

<b>A</b>		<b>F</b>		<b>S</b>	
ACEC class	8, 9	Finish	3	Site-mixed concrete	3, 5, 7
Acids	1	Fire resistance	2	Sitework standards	3
Admixtures	2, 3, 5	Formwork	3, 4	Special types of concrete	2
Aggregates	1, 3	<b>G</b>		Standardised prescribed mixes	1, 6, 7
Alkali-silica reaction	1	General purpose mixes	6	Storage of materials	3
APM	2, 9	Glossary of terms	9	Sulfates	1, 9
<b>B</b>		Ground aggressivity	2	<b>T</b>	
Blinding	2, 3	<b>J</b>		Testing	3, 5
<b>C</b>		Joints	2, 3, 5	Transportation	5
Carbonation	2	<b>L</b>		<b>W</b>	
Cement	3, 8	Loading	2	Water	3
Chlorides	1, 2	<b>M</b>			
Compaction	5	Mix design	1		
Cover	2, 4	Mixing methods	5		
Curing	3, 5	<b>P</b>			
<b>D</b>		Placing	5		
Design standard	1	Protection	3, 5		
Designated mixes	1, 6	Performance	2		
Durability	2	<b>R</b>			
<b>E</b>		Ready-mixed concrete	1, 3, 4		
Exposure	1, 7	Reinforced concrete	2		
		Reinforcement	2, 3, 4		

# Chapter 2.3

Timber preservation (natural solid timber)

---



# 2.3 Timber preservation (natural solid timber)

2.3

## CONTENTS

	Clause	Page
<b>DESIGN</b>		
Design standards	D1	1
Statutory requirements	D2	1
Durability	D3	1
Method of treatment	D4	1
Compatibility with metal components	D5	1
<b>MATERIALS</b>		
Materials standards	M1	1
<b>SITWORK</b>		
Sitework standards	S1	1
Protection and storage	S2	1
Treatment of cut surfaces	S3	1
<b>APPENDIX 2.3-A</b>		
Table 1 - Timber component groups and preservative treatment (based on BS 8417)		2
Table 2 - Natural durability of building timbers (heartwood only)		3
<b>APPENDIX 2.3-B</b>		
Additional sources of information		3
<b>INDEX</b>		4

## SCOPE

This Chapter gives guidance on meeting the Technical Requirements and recommendations for the protection of natural solid timber against fungal decay when exposed to damp conditions and against insect attack.

## LIMITATIONS

This Chapter only refers to treatment of natural solid timber. It does not relate to timber products such as plywood and wood particle boards.

This Chapter only gives acceptable treatment schedules and does not cover:

- condition of the timber before treatment
- techniques of operating the treatment process, which is the responsibility of the organisation carrying out the operation.

## DESIGN STANDARDS

### 2.3 - D1 Design shall meet the Technical Requirements

Design that follows the guidance below will be acceptable for timber selection and preservation.

## STATUTORY REQUIREMENTS

### 2.3 - D2 Timber and its preservative treatment shall comply with all statutory requirements

Design should be in accordance with relevant Building Regulations and other statutory requirements.

## DURABILITY

### 2.3 - D3 Timber and joinery used in the construction of dwellings shall either have adequate natural durability or, where treatment is undertaken, receive a satisfactory preservative treatment against fungal decay and insect attack

Timber and external joinery should be either:

- naturally durable and resistant to insect attack, or
- treated with preservative in accordance with this Chapter.

Appendix 2.3-A provides information to establish whether or not treatment is necessary for a particular element or timber species and also the type of treatment.

## METHOD OF TREATMENT

### 2.3 - D4 The method of treatment and treatment process shall reasonably ensure that the timber is safely and satisfactorily protected against fungal decay and insect attack

For timber or joinery which requires treatment, it is important that it is carried out to appropriate standards which are both suitable and safe. Treatments in accordance with procedures set out in British Standards, Codes of Practice or which have been satisfactorily assessed by an independent authority, will be acceptable, unless otherwise notified in writing.

## COMPATIBILITY WITH METAL COMPONENTS

### 2.3 - D5 Measures shall be taken to prevent adverse effects from incompatibility between metal components and treated timber

In situations where occasional dampness is expected, metal fittings in contact with timber treated with copper containing preservatives should be galvanized. Where timber treated with copper organic

preservatives is likely to become wet, fittings of austenitic stainless steel should be used.

Copper containing treatments can create a corrosive cell between mild steel and aluminium.

## MATERIALS STANDARDS

### 2.3 - M1 All materials shall: (a) comply with the Technical Requirements (b) take account of the design

Materials that comply with the design and the guidance given in Appendix 2.3-A will be acceptable for timber preservation.

The specification should state the specific treatment and standard required.

Preservative treatments should comply with all relevant standards and Codes of Practice. Proprietary treatments not contained in this Chapter or in British Standards should comply with Technical Requirement R3 (see Chapter 1.1 'Introduction to the Standards and Technical Requirements').

In all cases, preservatives must meet the requirements of the Control of Pesticides Regulations (1986) administered by the Health and Safety Executive.

The safety instructions published by the manufacturers should be followed.

References to British Standards and Codes of Practice include those made under the Construction Products Directive (89/106/EEC) and, in particular, appropriate European Technical Specifications approved by a European Committee for Standardisation (CEN).

In situations where occasional dampness is expected, metal fittings in contact with timber treated with copper containing preservatives should be galvanized. Where timber treated with copper containing preservatives is likely to become wet, fittings of austenitic stainless steel should be used.

## SITWORK STANDARDS

### 2.3 - S1 All sitework shall: (a) comply with the Technical Requirements (b) take account of the design (c) follow established good practice and workmanship

Sitework that complies with the design and the guidance below will be acceptable for timber preservation.

Timber treated with copper containing preservatives should be re-dried to a moisture content of 20% for at least 7 days before being in contact with metal fittings.

In situations where occasional dampness is expected, metal fittings in contact with timber treated with copper containing preservatives should be galvanized. Where timber treated with copper containing preservatives is likely to become wet, fittings of austenitic stainless steel should be used.

Check that when delivered to site, timber and joinery products have received the specified treatment. This should be stated on the delivery note.

## PROTECTION AND STORAGE

### 2.3 - S2 Timber and joinery shall be stored and protected to ensure it is in a suitable condition when installed in the dwelling

It is important when timber and joinery products are stored that they are:

- protected from damage immediately upon delivery
- protected from the weather
- stored off the ground
- stored in a way which limits the risk of distortion
- stored so that air can circulate freely around them.

## TREATMENT OF CUT SURFACES

### 2.3 - S3 Timber which has been preservative treated and cut shall be re-treated on the cut surfaces

Timber should not be cut after treatment but where this is unavoidable (either at the treatment plant or on site) all cut surfaces should be given two liberal applications of a suitable colour tinted preservative. The purpose of the colour tinting is to enable checks to be made that re-treatment has been carried out.

Only in situations where colour tinting will affect the appearance of the timber when fixed to the dwelling will clear preservatives be acceptable for this purpose.

The site applied preservative should be compatible with the original treatment.

# 2.3 Timber preservation (natural solid timber)

## APPENDIX 2.3-A

Table 1 - Timber component groups and preservative treatment required (based on BS 8417)

Component group	Examples	Hazard class	Desired service life	Preservative type required (see note 1)			Preservative treatment not required:
				Copper organic	Organic Solvent or Microemulsion	Boron	
Internal joinery, intermediate floor joists	Architraves, internal doors, intermediate floor joists	1	60	✓	✓	✓	unless a specific request for treatment against insect attack has been made
Roof timbers (dry)	Pitched roofs: rafters, purlins, joists, wall plates	1	60	✓	✓	✓	unless a specific request for treatment against insect attack has been made
Roof timbers (dry) in areas with house longhorn beetle	Ditto	1	60	✓	✓	✓	Where timber used is: <ul style="list-style-type: none"> <li>softwood - heartwood only (see note 2) and of durability class 1 - 3 (see note 3) or</li> <li>hardwood</li> </ul>
Roof timbers (risk of wetting)	Flat roofs joists, sarking, tiling battens, valley boards, timbers exposed to risk of condensation	2	60	✓	✓	✓	Where timber used is heartwood only (see note 2) and of durability class 1 - 2 (see note 3)
Roof timbers (risk of wetting) in areas with house longhorn beetle	Ditto	2	60	✓	✓	✓	Where timber used is heartwood only (see note 2) and of durability class 1 - 2 (see note 3)
External walls/ground floors	Timber frames, ground floor joists, I-beam studwork	2	60	✓	✓	✓	Where timber used is heartwood only (see note 2) and of durability class 1 - 2 (see note 3)
Sole plates (see note 4)		2	60	✓	✓	✓	Where timber used is heartwood only (see note 2) and of durability class 1 - 2 (see note 3)
External joinery, coated (not in ground contact) (see note 5)	Window frames, door frames, doors, cladding (coated), soffits, fascias, barge boards	3	30	✗ (see note 6)	✓	✓	Where timber used is heartwood only (see note 2) and of durability class 1 - 3 (see note 3)
Uncoated external timbers (not in ground contact)	Decking, balcony infill, cladding (uncoated)	3	15	✓	✗	✗	Where timber used is heartwood only (see note 2) and of durability class 1 - 2 (see note 3)
Timber in contact with the ground	Decking timber in ground contact, timber below dpc	4	15	✓	✗	✗	Where timber used is heartwood only (see note 2) and of durability class 1 - 2 (see note 3)

### Notes to table 1

- 1 Preservative treatment of timber should be in accordance with the recommendations of BS 8417 (with the exception of sole plates - see note 4). For preservatives listed in the supplement to the WPA Manual treatment recommendations are given in table 9, BS 8417.
- 2 Almost always, packs of timber contain sapwood. It should be assumed that timber is sapwood and preservative treated accordingly unless the timber has been specifically selected as heartwood only.
- 3 Natural durability classes are given in table 2.
- 4 Sole plates should be positioned above dpc. Preservatives used should be resistant to leaching or, for boron, treatment should be to full cross section retention standard. Treatment should be carried out in accordance with the WPA manual.
- 5 The hardwoods known as Meranti, Seraya or Lauan should be treated in the same way as European redwood / Scots Pine when used for joinery.
- 6 Generally, copper organic preservatives are not used for treating joinery items, but they can be used to treat claddings which are to be coated.

Table 2 - Natural durability of building timbers (heartwood only)

Durability Class	Timber Type	Timber Species	
1. Very durable	Softwoods	None	
	Hardwoods	Opepe Padauk-Andaman Afromosia Greenheart Guarea Iroko Jarrah Okan Pyinkado Teak Kapur  Padauk Peroba	- Malaysian - Sabah - Burma - White
2. Durable	Softwoods	Cedar	- Western red (imported)
	Hardwoods	Basralocus Ekki Chestnut Karri, Kempas Louro Oak  Mahogany	- Sweet  - Red - American White - European - American
3. Moderately durable	Softwoods	Pine Cedar Fir  Larch  Pine	- Caribbean pitch - Western red (UK) - Douglas (North American) - Douglas (UK) - Dunkeld (UK) - European - Hybrid - Japanese - Tamarack - Western - Maritime - American pitch
	Hardwoods	Keruing  Oak  Mahogany	- Sabah - Malaysian - Tasmanian - Turkey - African
4. Slightly durable	Softwoods	Fir  Pine    Redwood Fir  Hem-fir Pine Spruce  Spruce-pine-fir	- Noble - Silver - Canadian red - Corsican - Jack - Parana - Ponderosa - Radiata - Scots - Southern - Western white - Yellow - European - Balsam - Grand - USA and Canada - Lodgepole - Eastern Canadian - Engelmann - European (Whitewood) - Sitka - Western white - Canada
	Hardwoods	Elm  Oak Beech Elm	- Dutch - English - White - American red - Silver - Rock - Wych
5. Not durable	Softwoods	None	
	Hardwoods	Alder Beech Birch   Chestnut Lime Sycamore	- European - Silver - European - Paper - Yellow - European horse

APPENDIX 2.3-B

Additional sources of information

BS 8417 Preservation of Timber - Recommendations.

BS EN 599 - Part 1 Durability of wood and wood-based products - Performance of preventive wood preservatives as determined by biological tests - Part 1: Specification according to hazard class.

Industrial Wood Preservation - Specification and Practice ('the WPA Manual') (2008).

The Wood Protection Association, 1 Gleneagles House, Vernongate, Derby DE1 1UP

Tel: 01322 225104;

Email: info@wood-protection.org

# 2.3 Timber preservation (natural solid timber)

## INDEX

<b>A</b>		<b>H</b>		<b>S</b>	
Additional sources of information	3	Hardwoods	3	Sapwood	2
<b>C</b>		Hazard class	2	Softwoods	3
Compatibility with metal components	1	Health and safety executive	1	<b>T</b>	
Component group	2	House Longhorn beetle	2	Timber elements	2
Control of pesticides regulations	1	<b>I</b>		Timber type	3
Cut surfaces	1	Insect attack	1	Timber species	3
<b>D</b>		<b>M</b>		<b>V</b>	
Desired service life	2	Method of treatment	1	Very durable timber	3
Durability	1	Moderately durable timber	3		
Durable timber	3	<b>N</b>			
<b>E</b>		Natural durability	3		
External wall timbers	2	Non-durable timber	3		
<b>F</b>		<b>O</b>			
Flat roofs	2	Organic solvent	2		
Floors	2	<b>P</b>			
Fungal decay	1	Pitched roofs	2		
		Preservation	2		
		Protection	1		



---

# Part 3

## Ancillary technologies

---

### ■ 3.1 Low or zero carbon technologies





# Chapter 3.1

Low or zero carbon technologies

---



# 3.1 Low or zero carbon technologies

## CONTENTS

	Clause	Page
<b>INTRODUCTION</b>		1
Biomass boilers		1
Heat pumps		1
Solar photovoltaics		1
Solar thermal water heating		1
Wind turbines		1
<b>DEFINITIONS FOR THIS CHAPTER</b>		1
<b>DESIGN</b>		
Design Standards	D1	2
Statutory requirements	D2	2
Certification	D3	2
System design	D4	2
Building integration	D5	2
Electrical requirements	D6	3
Discharge	D7	3
Insulation of pipework	D8	3
Ground collectors	D9	3
Refrigerant pipework	D10	3
Fuel storage	D11	3
Clean Air Act	D12	3
Access	D13	4
Provision of Information	D14-D15	4
<b>MATERIALS</b>		
Materials standards	M1	4
Standards	M2	4
Fixings	M3	4
Flashings	M4	4
Pipes and insulation	M5	4
<b>SITWORK</b>		
Sitework standards	S1	4
Competancy of installers	S2	4
Sequence of work	S3	5
Location	S4	5
Fixing	S5	5
Stability	S6	5
Weather resistance	S7	5
Access	S8	5
Handling, storage and protection	S9	5
Testing and commissioning	S10	5
Handover requirements	S11	5
<b>APPENDIX 3.1 - A</b>		6
Additional information		
<b>INDEX</b>		6

## SCOPE

This Chapter gives guidance on meeting the Technical Requirements and recommendations for low or zero carbon (LZC) technologies.

**INTRODUCTION**

This Chapter gives guidance on low or zero carbon (LZC) technologies acceptable to NHBC.

Other systems that follow the general principles of this Chapter may also be acceptable subject to specific agreement with NHBC.

Additional requirements for solid fuel and oil fired boilers are given in Chapter 6.8 'Fireplaces, chimneys and flues'. Guidance on other internal services is given in Chapter 8.1 'Internal services'.

The illustrations provided within the Introduction are generic and do not indicate the only possible systems acceptable to NHBC.

The LZC technologies covered in this Chapter include:

**BIOMASS BOILERS**

Biomass boilers burn wood pellets or wood chips for space and/or water heating.

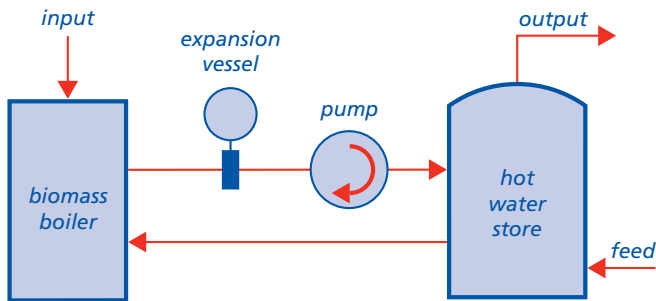

**HEAT PUMPS**

Heat pump systems provide space and/or water heating by transferring heat from a low temperature heat source. The most common heat sources are the ground, outdoor air or exhaust air.

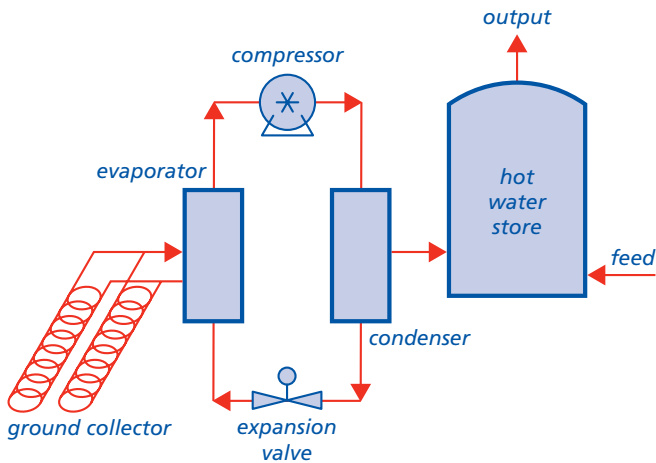

**SOLAR PHOTOVOLTAICS**

Solar Photovoltaic (PV) systems convert solar radiation into electricity.

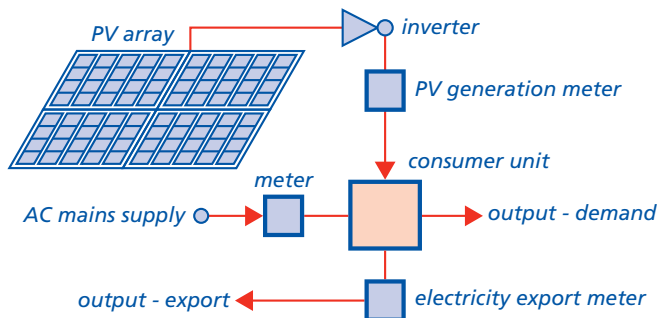

**SOLAR THERMAL WATER HEATING**

Solar thermal systems harness solar radiation for space and/or water heating.

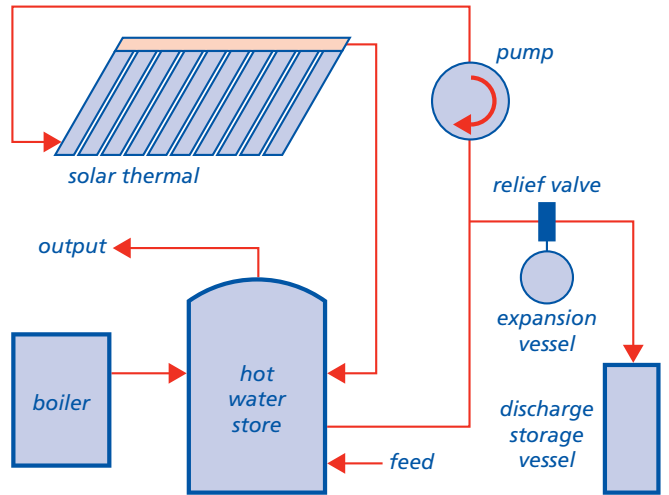

**WIND TURBINES**

Wind turbine systems convert energy from the wind into electricity.

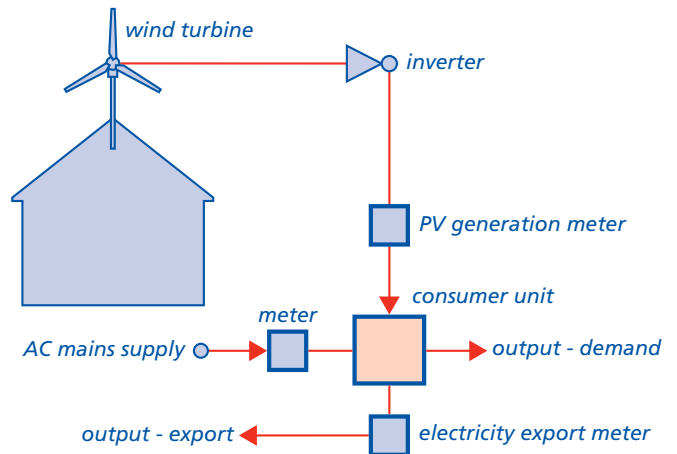

**DEFINITIONS FOR THIS CHAPTER**

**CONTROLS**

Controls are used to operate and/or regulate the system and may be electrical or mechanical.

**EXCLUSION ZONE**

An area where entry is restricted during periods when maintenance is in progress, to prevent risk of injury or loss of life.

**FIXING**

A component which is used to attach the LZC technology to the structure.

**FLASHING**

A piece of material, usually metal, plastic or composite, installed to prevent water from penetrating the building.

**GROUND COLLECTORS**

The component of a ground source heat pump system which absorbs heat from the ground. Collectors can be installed either horizontally or vertically in the ground. They may also be incorporated into proprietary foundation systems.

**INTERFACE**

Interconnection between two or more components.

**INTERSTITIAL CONDENSATION**

Condensation occurring within or between the layers of the building envelope.

**INVERTER**

A device that convert direct current into alternating current.

**ISLANDING (ISLAND MODE OPERATION)**

Where a LZC technology feeds the network or local distribution system during a planned or unscheduled loss of mains supply.

**LOW OR ZERO CARBON (LZC) TECHNOLOGIES**

A term applied to renewable sources of energy and also to technologies which are significantly more efficient than traditional solutions or which emit less carbon in providing heating, cooling or power.

**METER**

Device that measures consumption and/or generation of energy.

**OPEN LOOP SYSTEM**

A heat pump system that extracts water from an underground source, pumps it through a heat exchanger and returns it underground.

**PARALLEL ELECTRICAL GENERATION**

A system in which building loads can be fed simultaneously from the national grid or electricity supply grid and on-site sources such as wind turbines and photovoltaic panels.

**PERFORMANCE**

The manner or quality of functioning for a material, product or system.

**REFRIGERANT PIPEWORK**

Carries refrigerant between the indoor and outdoor unit of a split system. Normally made of copper and must be insulated and protected from damage.

**RENEWABLE ENERGY**

Energy from naturally available sources that can be replenished including energy from the sun, the wind and tides, and from replaceable matter such as wood or other plant material.

**SPLIT SYSTEM**

A type of heat pump in which the condenser is located indoors, the evaporator is located outdoors, and the two are linked by refrigerant pipework.

**SURFACE CONDENSATION**

Condensation occurring on surfaces of the building.

**SWITCHGEAR**

The combination of electrical switches, fuses and/or circuit breakers used to isolate electrical equipment.

**VAPOUR CONTROL LAYER**

A material that restricts the passage of water vapour into the construction to reduce the risk of interstitial condensation.

**DESIGN STANDARDS****3.1 - D1 Design shall meet the technical requirements**

Design that follows the guidance below will be acceptable for LZC technologies.

**STATUTORY REQUIREMENTS****3.1 - D2 Design shall comply with all relevant statutory requirements**

Design should be in accordance with relevant Building Regulations and other statutory requirements.

**CERTIFICATION****3.1 - D3 Low or zero carbon technologies shall be certified in accordance with appropriate standards**

LZC technologies should have current certification confirming satisfactory assessment by an appropriate independent technical approvals authority acceptable to NHBC.

System products and installations that are assessed and certified through the Microgeneration Certification Scheme (MCS) will normally be acceptable to NHBC.

Further details of MCS can be found at:

[www.microgenerationcertification.org](http://www.microgenerationcertification.org)

Other certification bodies or test documentation may be acceptable if they are considered by NHBC to be a suitable alternative.

When requested by NHBC the certification and relevant test documentation should be made available.

**SYSTEM DESIGN****3.1 - D4 Low or zero carbon technologies shall be designed to ensure satisfactory performance**

Items to be taken into account include:

**(a) location**

The output from certain LZC technologies may be affected by factors such as orientation, roof pitch, shading and geographical location.

For stand-alone wind turbine systems suitable exclusion zones should be provided in accordance with the manufacturer's recommendations.

**(b) systems**

Each system should generally be supplied from one manufacturer as a package and not as individual components or materials. However, where components from more than one manufacturer are used they should be compatible to ensure satisfactory performance.

**(c) performance**

LZC technologies should be designed in accordance with the manufacturer's recommendations and the certification scheme requirements and standards.

LZC technologies designed to contribute towards space and water heating should be designed in accordance with the performance requirements in Chapter 8.1 'Internal services' (Design).

**(d) compatibility**

Systems should be compatible with the building. Multiple systems should also be compatible with each other.

**(e) acoustic performance**

The design and location of LZC technologies should take account of noise and vibration. Both internal noise and external noise should be considered. The effect on neighbouring properties should be considered, particularly the relative positioning of openings in relation to the LZC technology.

**(f) drawings and specifications**

Drawings and specifications should indicate clearly which manufacturer and/or installer is responsible for each system, including interfaces.

**BUILDING INTEGRATION****3.1 - D5 Low or zero carbon technologies shall not adversely affect the stability or weather resistance of the building**

Items to be taken into account include:

**(a) structural integrity**

The design of the structure to which the LZC technologies will be attached should take account of:

- the self-weight of the LZC components
- imposed loads
- wind loads
- snow loads
- dynamic loading (where relevant).

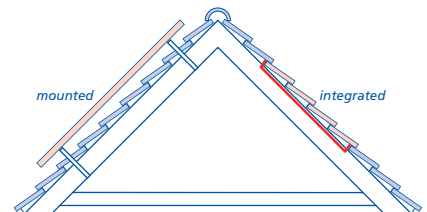

Foundations for stand-alone LZC technologies should be designed by an Engineer in accordance with Technical Requirement R5.

Where stand-alone systems are installed the foundations and anchor points should be designed to withstand the structural forces acting upon them.

Wind turbines should be designed in accordance with BS EN 61400.

**(b) supporting structure**

The structure to which the LZC technology is attached should be assessed to ensure that it is able to accept the design loadings and prevent detrimental effects arising from movement or vibration.

**(c) fixings**

Fixings, supports, bracketry and mounting frames should be designed to accommodate all static and dynamic loads in accordance with the manufacturer's recommendations.

Fixings, supports, bracketry and mounting frames should be designed to take account of ventilation and drainage requirements of the LZC technology.

**(d) weather resistance**

The interface between the LZC technology and the building should be designed to ensure that moisture is prevented from reaching the interior, or any part of the structure that could be adversely affected by its presence.

To ensure satisfactory performance, the interface of a roof or wall integrated system and the part of the roof covering or wall cladding it replaces should be weatherproofed by appropriate flashings and sealed to limit air leakage.

Weatherproofing details that rely solely on sealant are not acceptable.

**(e) thermal bridging and condensation**

To avoid the potential for surface and/or interstitial condensation, the design should take account of thermal bridging, particularly where any part of the system, including fixings, penetrates the thermal envelope of the building.

**(f) corrosion protection**

Metalwork used for fixings, supports, bracketry or mounting frames should have adequate protection against corrosion.

Where two metals are to be joined they should be compatible or isolated from each other to prevent bimetallic corrosion.

Aluminium and aluminium alloys should not come into contact with cementitious material.

**ELECTRICAL REQUIREMENTS**

**3.1 - D6 The electrical installation shall be in accordance with relevant regulations**

The electrical installation should comply with BS 7671 'Requirements for Electrical Installations'.

Where parallel electrical generation occurs, inverters should have a current Engineering Recommendation G83/1 Type Test certificate and comply with all other parts of ER G83/1 for standard

installations. Larger installations should comply with ER G59/2.

The electrical installation should be capable of being isolated from all other electrical sources when required for maintenance or testing.

LZC technologies which generate electricity and are connected to the mains should automatically disconnect when there is a mains power failure. This is to prevent them from feeding the network or local distribution system during a planned or unscheduled loss of mains supply. This is known as 'islanding'.

**DISCHARGE**

**3.1 - D7 Discharge from low or zero carbon technologies shall terminate safely**

Discharge from solar thermal water heating systems should be into a storage vessel. The vessel and discharge pipework should be suitable to withstand high temperatures.

All air source systems should incorporate an automatic defrost cycle and suitable condensate drainage.

**INSULATION OF PIPEWORK**

**3.1 - D8 Pipework shall be designed to prevent freezing**

Where there is a risk of pipes freezing, they should be insulated, particularly when at, or close to, ground level.

**GROUND COLLECTORS**

**3.1 - D9 Ground collectors shall be installed with regard for structural and environmental factors**

Excavations for the installation of ground collectors should not adversely affect aquifers, foundations, drainage, water supply pipes and other services. Design should take account of local planning authority guidance including where excavations are close to trees and hedgerows (see Chapter 4.2 'Building near trees').

The design of ground collectors should specify their depth and layout to avoid freezing of adjacent ground.

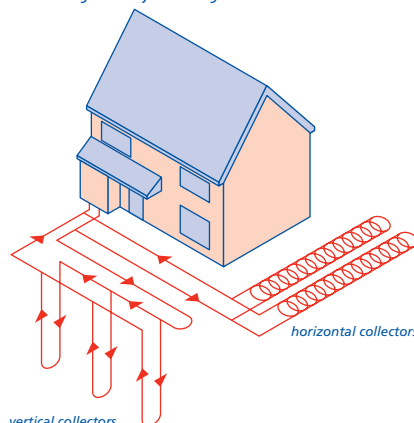

Where open loop systems are proposed, consultation with the Environment Agency, Northern Ireland Environment Agency or Scottish Environment Protection Agency, as appropriate, should be made.

Open loop systems may require one or more of the following:

- a licence to investigate groundwater
- an abstraction licence
- a discharge consent.

**REFRIGERANT PIPEWORK**

**3.1 - D10 Refrigerant pipework shall be designed to ensure adequate performance**

Refrigerant pipework connecting split systems should be of refrigerant quality copper pipe or other material as recommended by the manufacturer. The pipe should be insulated and the insulation should incorporate a vapour control layer to prevent ice build-up.

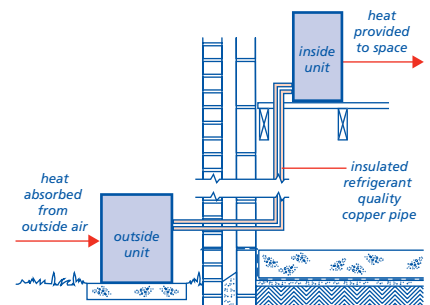

**FUEL STORAGE**

**3.1 - D11 Fuel storage for biomass boilers shall be suitable for the installation**

The location of fuel storage should take account of access for delivery.

Fuel stores should:

- be of a suitable size to take account of peak load and period of demand
- have fire detection and extinguishing equipment where elevated dust levels are expected
- have appropriate fire resistance and separation to prevent fire and gases entering other parts of the building, where they are integral.

Guidance is given in The HVCA Guide to Good Practice Installation of Biofuel Heating (TR/38).

**CLEAN AIR ACT**

**3.1 - D12 Biomass boilers installed in smoke controlled areas shall comply with relevant legislation**

Biomass boilers that are to be installed within a smoke controlled area should comply with the Clean Air Act 1993 or Clean Air (Northern Ireland) Order 1981.

## ACCESS

**3.1 - D13 Appropriate arrangements shall be provided for the purposes of cleaning, inspection, maintenance and repair of low or zero carbon technologies**

Design should take account of safe access to the LZC technologies, including switchgear, inverters, meters and controls, for cleaning, inspection, maintenance and repair of systems.

## PROVISION OF INFORMATION

**3.1 - D14 Designs and specifications shall be produced in a clearly understandable format and include all relevant information**

Designs and specifications should include:

- full set of current drawings
- manufacturers' specifications
- fixing schedule
- interfaces
- controls
- on-site testing
- commissioning schedule.

**3.1 - D15 All relevant information shall be distributed to appropriate personnel**

Designs and specifications should be issued to consultants, relevant specialist subcontractors, site supervisors and/or suppliers as appropriate.

## MATERIALS STANDARDS

**3.1 - M1 All products and materials shall:**

- (a) meet the Technical Requirements  
(b) take account of the design

Products and materials that comply with the design and the guidance below will be acceptable for LZC technologies.

Products and materials for LZC technologies should comply with all relevant standards, including those listed below. Where no standards exist, Technical Requirement R3 applies (see Chapter 1.1 'Introduction to the Standards and Technical Requirements').

References to British Standards and Codes of Practice include those made under the Construction Products Directive (89/106/EEC) and, in particular, appropriate European Technical Specifications approved by a European Committee for Standardisation.

## PRODUCTS

**3.1 - M2 Products used for low or zero carbon technologies shall be adequate for their location and intended use**

Relevant standards include:

- BS EN 12975-1– Thermal solar systems and components. Solar collectors. General requirements

- BS EN 12976-1 – Thermal solar systems and components. Factory made systems. General requirements
- BS EN 61215 – Crystalline silicon terrestrial photovoltaic (PV) modules. Design qualification and type approval
- BS EN 61646 – Thin film terrestrial photovoltaic (PV) modules. Design qualification and type approval
- EN 14511 Parts 1-4 – Air conditioners, liquid chilling packages and heat pumps with electrically driven compressors for space heating and cooling
- BS EN 61400-1 – Wind turbines. Design requirements
- BS EN 61400-2 – Wind turbines. Design requirements for small wind turbines
- BS EN 14785 – Residential space heating appliances fired by wood pellets. Requirements and test methods
- BS EN 12809 – Residential independent boilers fired by solid fuel
- BS EN 303-5 – Heating boilers for solid fuels, hand and automatically fired, nominal heat output of up to 300kW. Terminology, requirements, testing and marking.

## FIXINGS

**3.1 - M3 Fixings shall be of durable material and provide satisfactory performance**

Fixings should be manufactured from:

- phosphor bronze
- silicon bronze
- stainless steel to BS EN ISO 3506
- mild steel with coatings to BS EN 12329, BS EN ISO 2082, BS EN 1461, or other appropriate treatment in accordance with BS EN ISO 12944 or BS EN ISO 14713
- aluminium alloy to BS EN 573 and BS EN 755.

Stainless steel should comply with BS EN 10088. Mild steel should be galvanised in accordance with BS EN 10346.

Materials that comply with recognised Standards, which provide equal or better performance to those above, would also be acceptable.

Other materials should be assessed in accordance with Technical Requirement R3.

## FLASHINGS

**3.1 - M4 Materials for flashings shall provide satisfactory performance**

The following are acceptable as flashings:

- rolled lead sheet (at least code 4) complying with BS EN 12588
- aluminium and aluminium alloys to BS EN 485 and BS EN 573 (0.6mm to 0.9mm thick) and protected from contact with mortar by a coating of bituminous paint
- zinc alloys to BS EN 988 and 0.6mm thick

- copper to BS EN 1172 and 0.55mm thick fully annealed.

Where two metals are to be joined they should be compatible and not cause bimetallic corrosion in that environment. Alternatively they should be isolated from each other.

Proprietary flashing kits and flashings, including plastic and composite, should be assessed in accordance with Technical Requirement R3.

## PIPES AND INSULATION

**3.1 - M5 Pipes and insulation shall provide satisfactory performance**

Materials used for pipes and insulation should be suitable for the intended purpose and provide satisfactory performance for the life of the system.

Pipes should comply with relevant codes and standards or be independently assessed for their intended use in accordance with Technical Requirement R3.

Insulation materials should be inert, durable and should not be adversely affected by moisture or vapour. They should also comply with relevant codes and standards or be independently assessed for their intended use in accordance with Technical Requirement R3.

## SITWORK STANDARDS

**3.1 - S1 All sitework shall:**

- (a) meet the Technical Requirements  
(b) take account of the design  
(c) follow established good practice and workmanship

Sitework that complies with the design and guidance below will be acceptable for LZC technologies.

All relevant information suitable for the use of installers should be available on site before work on the LZC technology starts, including:

- full set of current drawings
- manufacturer's specification
- fixing schedule
- details of all interfaces and controls
- on-site testing regime
- commissioning schedule.

## COMPETENCY OF INSTALLERS

**3.1 - S2 Systems shall be installed by competent operatives**

Systems should be installed by operatives who:

- are competent and familiar with the system being installed, and



- can demonstrate that they have been trained in accordance with the MCS installer standards, or other suitable scheme acceptable to NHBC.

The installation, including interfaces, should be in accordance with the design.

## SEQUENCE OF WORK

### 3.1 - S3 Low or zero carbon technologies shall be installed in accordance with a suitable schedule

To ensure performance, certain LZC systems and ancillary components should be installed in a logical and timely sequence in accordance with the manufacturer's recommendations.

## LOCATION

### 3.1 - S4 Low or zero carbon technologies shall be correctly located

LZC technologies, including ancillary components should be located and identified in accordance with the manufacturer's recommendations and the design.

## FIXING

### 3.1 - S5 Low or zero carbon technologies shall be securely fixed

LZC technologies, including ancillary components should be fixed in accordance with the manufacturer's recommendations and the design.

The type, size, number and positioning of all fixings, including their fitting tolerance, should be in accordance with the manufacturer's recommendations and the design.

Particular attention should be given to:

- the provision of suitable locking nuts and washers
- the isolation of dissimilar metals
- the isolation of aluminium from cementitious material.

Notching, drilling or chasing of structural components to accommodate service pipes or cables should either comply with Chapter 8.1 'Internal services', or be designed by an Engineer in accordance with Technical Requirement R5.

## STABILITY

### 3.1 - S6 The building structure shall be constructed to take account of the low or zero carbon technology being installed

LZC technologies should be installed so as not to adversely affect the stability of the building to which they are fixed, in accordance with the manufacturer's recommendations and the design.

## WEATHER RESISTANCE

### 3.1 - S7 Low or zero carbon technologies shall not compromise the weather resistance of the building to which they are installed

LZC technologies should be installed in accordance with the manufacturer's recommendations and the design to ensure adequate weather resistance and limit air leakage.

The interface between the LZC technologies and the building should ensure that moisture is prevented from reaching the interior or any part of the structure that could be adversely affected by its presence.

Appropriate flashings and seals should be correctly installed in accordance with the manufacturer's recommendations and the design.

Interface weatherproofing details that rely solely on sealant are not acceptable.

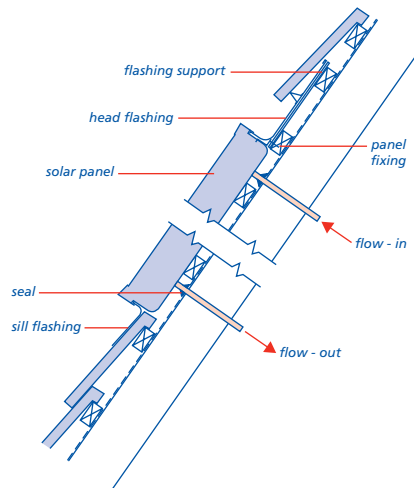

## ACCESS

### 3.1 - S8 Access to low or zero carbon technologies shall be provided in accordance with the design

Access to LZC technologies and ancillary components should be provided in accordance with the manufacturer's recommendations and the design.

## HANDLING, STORAGE AND PROTECTION

### 3.1 - S9 Materials, products and systems shall be handled, stored and protected in a satisfactory manner to prevent damage, distortion, weathering and degradation

Items to be taken into account include:

#### (a) handling and storage

LZC technologies should be transported, lifted, handled and stored in accordance with the manufacturer's recommendations.

The delivery of products to site should be sequenced to avoid storage where possible.

#### (b) protection

Low or zero carbon technologies should be protected to avoid the risk of damage.

Ground collectors should be protected and tested prior to backfilling.

## TESTING AND COMMISSIONING

### 3.1 - S10 Low or zero carbon technologies shall be tested and commissioned in accordance with the commissioning schedule

The installer should check:

- the safety of the system
- the correct installation of the system in accordance with the certification requirements, manufacturer's recommendations and the design
- the correct operation of the system in accordance with the certification requirements, manufacturer's recommendations and the design.

Upon completion, the installer should provide a certificate to confirm that the LZC technology has been installed, tested and commissioned in accordance with the above.

## HANDOVER REQUIREMENTS

### 3.1 - S11 Detailed information including instructions shall be provided to the end user

The pack of information provided to the end user by the house builder should include:

- user instructions for the systems installed
- a completed manufacturer's certificate from an acceptable independent assessment organisation, MCS or suitable alternative
- a completed installer's certificate from an acceptable independent assessment organisation, MCS or suitable alternative.

The pack should also include:

- contact details for the manufacturer and installer
- key components installed
- fuel type and source
- maintenance and servicing requirements
- warranties and/or guarantees for the LZC technology.

# 3.1 Low or zero carbon technologies

## APPENDIX 3.1-A

### Additional information:

BS EN 12975-2: 2006	Thermal solar systems and components. Solar collectors. Test methods
BS EN ISO 14713: Part 1-4	Zinc coatings. Guidelines and recommendations for the protection against corrosion of iron and steel in structures
ER G59/2	Recommendations For The Connection Of Generating Plant To The Distribution Systems Of Licensed Distribution Network Operators
ER G83/1	Recommendations for the connection of small –scale embedded generators (up to 16 A per phase) in parallel with public low-voltage distribution networks
BRE Digest 489	Wind loads on roof –based photovoltaic systems
BRE Digest 495	Mechanical installation of roof-mounted photovoltaic systems
	The HVCA Guide to Good Practice Installation of Biofuel Heating (TR/38)
	The HVCA Guide to Good Practice Installation of Heat pumps (TR/30)
British Wind Energy Association	Small Wind Turbine Performance and Safety Standard
Photovoltaics in buildings	Guide to the installation of PV systems. 2nd Edition (DTI publication 06/1972)
CE72	Energy Efficiency Best Practice in Housing - Installing small wind-powered electricity generating systems
CE131	Energy Efficiency Best Practice in Housing - Solar water heating systems

## INDEX

<b>A</b>		<b>G</b>		<b>S</b>	
Access	5	Ground collectors	3	Sequence of work	4
<b>B</b>		<b>H</b>		Solar photovoltaics	1
Biomass boilers	1	Handling, storage and protection	5	Solar thermal water heating	1
Building integration	2	Handover requirements	5	Stability	5
<b>C</b>		Heat pumps	1	System design	2
Certification	2	<b>I</b>		<b>T</b>	
Clean Air Act	3	Insulation of pipework	3	Testing and commissioning	5
Competency of installers	4	<b>L</b>		<b>W</b>	
<b>D</b>		Location	5	Weather resistance	5
Definitions	1	<b>P</b>		Wind turbines	1
Discharge	3	Pipes and insulation	4		
<b>E</b>		Products	4		
Electrical requirements	2	<b>R</b>			
<b>F</b>		Refrigerant pipework	3		
Fixing/s	4, 5				
Flashings	4				
Fuel storage	3				

---

# Part 4

## Foundations

---

- 4.1 Land quality - managing ground conditions
- 4.2 Building near trees
- 4.3 No longer allocated
- 4.4 Strip and trench fill foundations
- 4.5 Raft, pile, pier and beam foundations
- 4.6 Vibratory ground improvement techniques





# Chapter 4.1

Land quality - managing ground conditions

---



# 4.1 Land quality - managing ground conditions

## CONTENTS

	Clause	Page
<b>Objectives</b>		1
<b>Procedural summary</b>		1
<b>PROCEDURAL FLOW CHART</b>		2
<b>DESIGN</b>		
<b>Initial assessment</b>		
Desk study	D1	3
Walkover survey	D2	3
Results	D3	4
<b>Where hazards are not suspected</b>		
Basic investigation	D4	4
<b>Where hazards are suspected</b>		
Detailed investigation	D5	4
Managing the hazards	D6	5
Documentation and verification	D7	5
Unforeseen hazards	D8	6
<b>APPENDIX 4.1-A</b>		
References		6
<b>APPENDIX 4.1-B</b>		
Potential hazards and associated risks		7
<b>APPENDIX 4.1-C</b>		
Site investigation techniques		8
<b>APPENDIX 4.1-D</b>		
“Suitable persons” and “Consultants or Specialists”		9
<b>INDEX</b>		9

## SCOPE

This Chapter gives guidance on meeting the Technical Requirements and recommendations for assessing the site with regard to managing the ground conditions.

### Hazardous sites

Builders are reminded that where a site\* is hazardous, NHBC Rules state that, they must notify NHBC in writing at least 8 weeks before work begins.

Failure to provide NHBC with information about hazardous sites may result in a delay in processing the registration, hold up construction work on site and the issue of the 10 year cover.

\* Site is defined in NHBC Rules as an area of land which is covered by a single detailed planning consent.

### Objectives

This Chapter provides a framework for managing **geotechnical** and **contamination** risks with the objective of ensuring that:

- all sites are properly assessed and investigated
- foundations and substructure designs are suitable for the ground conditions
- sites are properly remediated where necessary or appropriate design precautions are taken, and
- appropriate documentation and verification can be provided to NHBC.

#### Assessment of geotechnical and contamination issues

Assessment should be carried out by direct investigation and examination of the ground, supplemented where necessary by results of laboratory testing on samples obtained.

Examples of potential hazards and associated risks relating to geotechnical and contamination issues are listed in Appendix 4.1-B.

Additionally, contaminated land should be assessed using the following framework:

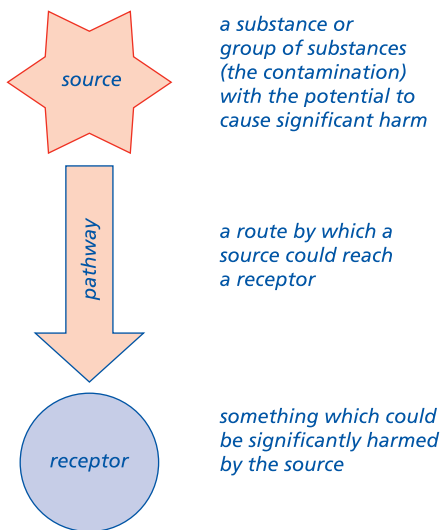

Contamination may exist as a result of past industrial activities, the dumping of waste materials, spills or the presence of naturally occurring substances.

For contaminated land to exist the source, pathway and receptor (known as the pollutant linkage) must all exist.

A written or diagrammatic representation of the site characteristics (known as a Conceptual Model) should be produced to show the possible relationships between the contaminants, pathways and receptors.

### Procedural summary

The processes to assess and manage the ground conditions are:

- illustrated in the **Procedural flowchart**, and
- described in detail in the pages that follow.

Useful references are contained in Appendix 4.1-A.

**Initial assessment** (Clauses D1 to D3) NHBC requires **all** sites to be assessed by a **Desk study** and a **Walkover survey**.

The **Results** should be used to determine whether or not hazards are known or suspected.

**Basic investigation** (Clause D4) Where hazards are not suspected a **basic investigation** will be required to support the results of the initial assessment.

**Detailed investigation**(Clause D5) Where hazards are known or suspected a **detailed investigation** will be required.

**Further assessment** After the basic or detailed investigation has been undertaken a further assessment is required to confirm that all the objectives have been met. Where the results are inconclusive, further site investigation will be required.

**Where hazards are found** (Clause D6) Where hazards are identified, design precautions or remediation will be required to minimise their effects.

**Documentation and verification** (Clause D7) NHBC will require documentation to show that:

- the site has been properly assessed and investigated
- where necessary, suitable precautions are incorporated into the design
- all necessary remediation has been carried out.

**Unforeseen hazards**(Clause D8) If any unforeseen hazards are found during the course of construction, further investigation may be required.

# 4.1 Land quality - managing ground conditions

## Procedural flowchart

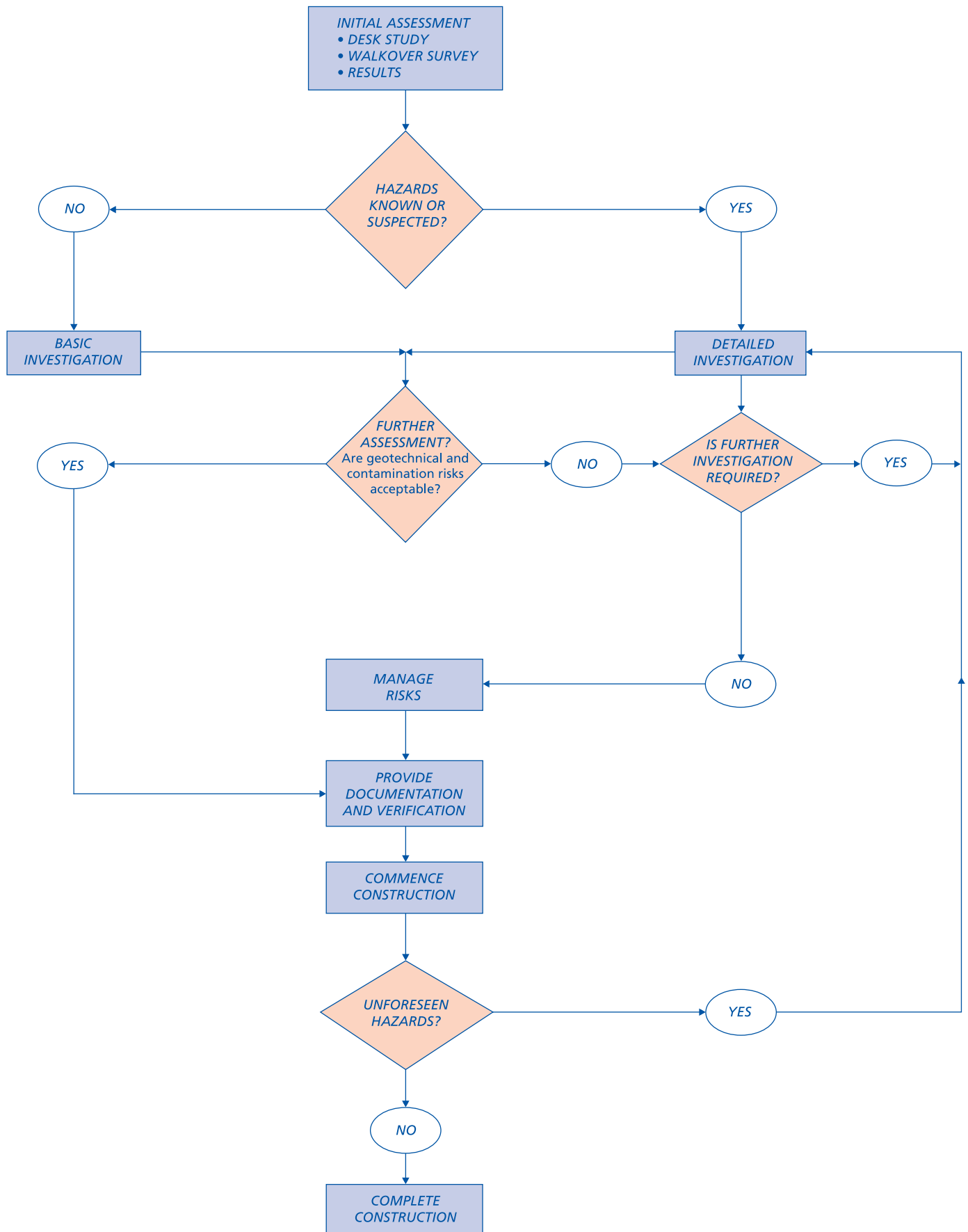

4.1



**DESIGN STANDARDS**

**INITIAL ASSESSMENT**

**DESK STUDY**

**4.1 - D1 A desk study of the site and the surrounding area shall be undertaken by a suitable person**

A desk study is the collection and examination of existing information obtained from a wide variety of sources.

It should indicate any potential hazards at an early stage and provide a basis for the investigation.

A suitable person, as described in Appendix 4.1-D, should carry out the desk study.

Items to be taken into account include:

**(a) soils, geology, surface water and ground water**

Investigate the soils, geology, surface water and ground water of the site and surrounding area.

**(b) use of the site and surrounding area**

Research the current use and history of the site and surrounding area to assess the potential problems including those which may have been left by:

- industrial, commercial and agricultural uses including storage
- mining
- quarrying
- landfilling and tipping.

Some sites may have been associated with more than one process.

**(c) sources of information**

Refer to key sources of information including:

- the Environment Agency or its equivalent, for example coastal erosion, landfill sites, details of water abstraction
- the Local Authority, for example planning and environmental health
- county records offices, libraries, museums, and local history sources
- the utility companies
- the Coal Authority
  - mining reports - past, present and proposed mining
- the British Geological Survey
  - maps and information
- soil survey maps
- the Ordnance Survey
  - current and previous editions of plans and aerial photographs.

The above list is not exhaustive and local sources may be relevant.

**(d) existing site information**

Review all available information from:

- the vendor of the site
- previous in-house information
- ongoing monitoring.

**INITIAL ASSESSMENT**

**WALKOVER STUDY**

**4.1 - D2 A walkover survey of the site and the surrounding area shall be undertaken by a suitable person**

A walkover survey is a direct inspection of the site and the surrounding area carried out in conjunction with the desk study.

Look for indications of any potential hazards to provide a basis for the investigation.

A photographic record of the site can help in the reporting of the walkover survey.

A suitable person, as described in Appendix 4.1-D, should carry out the walkover survey.

Items to be taken into account include:

**(a) topography**

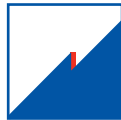

What is the significance of any abrupt changes in slope?



Is there evidence of overburden on slopes?



Are there any signs of landslip, e.g. tilting trees, posts or walls?

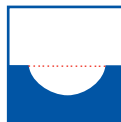

Are there signs of local subsidence?

**(b) soils and rocks**



What is the basic type of ground?

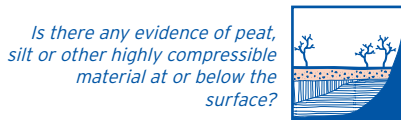

Is there any evidence of peat, silt or other highly compressible material at or below the surface?



Is there cracking or stickiness of the surface which may indicate a shrinkable sub-soil?

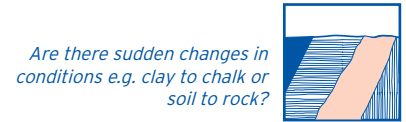

Are there sudden changes in conditions e.g. clay to chalk or soil to rock?

**(c) surface water and ground water**

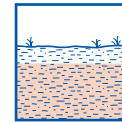

Is a high water table indicated, e.g. by waterlogged ground?

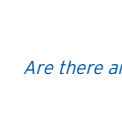

Are there any signs of flooding?



Are there any reeds or water-loving plants?

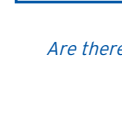

Are there any springs, ponds, wells, ditches or streams?

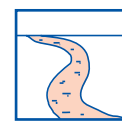

Is there any discoloured water? What is its source?

**(d) vegetation (which may indicate the nature of the soils)**

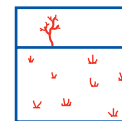

Is the vegetation sparse, dead or dying?

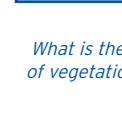

What is the type and condition of vegetation on land adjoining the site?

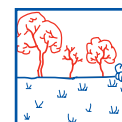

What are the species, height and condition of the trees?

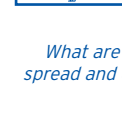

What are the species, height, spread and condition of hedges and scrub on clay?



Is there evidence of former trees, hedges or scrub on clay?

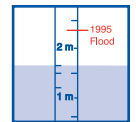

4.1

**(e) structural information**

Is there evidence of damage to structures, e.g. cracking in buildings, on or around the site?

Is there other evidence of movement?

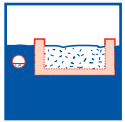

Is there evidence of any structures or services below ground?

**(f) local information**

Is there local knowledge of the site e.g. mining, refuse tipping, flooding?

Are there local industrial history records indicating past and present uses of the site?



Do local place names and street names give clues e.g. Brickfield Cottage, Water Lane?

**INITIAL ASSESSMENT****RESULTS****4.1 - D3 The results of the desk study and walkover survey shall be recorded and evaluated by a suitable person**

A suitable person, as described in Appendix 4.1-D, should record the results of the initial assessment and evaluate whether hazards are suspected.

The record should include the following as appropriate:

- site plans with dates, showing:
  - previous uses of the site
  - current uses of the site
  - the proposed site layout
- details of the geology of the site from:
  - geological maps
  - previous site investigations
  - laboratory test results
- photographs of the site to show particular points of interest or concern, (e.g. areas of ground instability), with dates
- copies and interpretation of aerial photographs, with dates
- a list of sources of information consulted (e.g. Environment Agency, Coal Authority, etc.) and copies of the information obtained.

**Sites where hazards are not suspected****BASIC INVESTIGATION****4.1 - D4 A basic investigation of the site shall be carried out and recorded by a suitable person to the satisfaction of NHBC**

Where the results of the initial assessment indicate that hazards are not suspected on the site, this should be substantiated by carrying out a **basic investigation**.

This approach is to provide assurance for all sites, regardless of how free of hazards they may appear.

Only suitable persons with the skills and knowledge described in Appendix 4.1-D should carry out the basic investigation.

The following provides a specification for the basic investigation for all sites.

Trial pits should be located so as to be representative of the site. (For more detailed information refer to BS EN 1997-2)

The number and depth of trial pits needed depends upon:

- the proposed development
- how inconsistent the soil and geology is across the site
- the nature of the site.

The depth of the trial pits should not usually be less than 3m.

**Items to be taken into account include:****(a) geotechnical investigation**  
(see Appendix 4.1-C)

A basic geotechnical investigation should be carried out. This will include trial pits and, where they do not provide sufficient information, boreholes will be necessary.

Physical tests, such as plasticity index tests, should be carried out as appropriate to support the results of the initial assessment.

Trial pits should be located outside the likely foundation area. The distance from the edge of the foundation should not be less than the trial pit depth.

**(b) contamination investigation**  
(see Appendix 4.1-C)

A basic contamination investigation should be carried out as part of the basic geotechnical investigation. This should consist of sampling and testing of soil taken from trial pits during the geotechnical investigation, as found to be necessary from the outcome of the initial assessment.

During the excavation of the trial pits the use of sight and smell may help to identify certain contaminants.

Where there is any doubt about the condition of the ground a detailed investigation should be carried out (see 4.1 - D5).

**FURTHER ASSESSMENT**

If the **basic investigation** reveals the presence of geotechnical and/or contamination hazards or has not addressed all of the original objectives further **detailed investigations** should be carried out (see Clause D5).

If the **basic investigation** addresses all of the original objectives refer to **Clause D7, Documentation and Verification**.

**Sites where hazards are suspected****DETAILED INVESTIGATION****4.1 - D5 Where hazards are suspected a detailed investigation of the site shall be carried out, under the supervision of a consultant or specialist acceptable to NHBC, to determine and report on the nature and extent of all hazardous ground conditions**

A **detailed investigation** should be carried out where:

- hazards are suspected from the outset
- the initial assessment identified hazards, or
- the basic investigation identified hazards.

The basic (geotechnical and contamination) investigation should form the minimum requirement for any site investigation.

In addition to the basic investigation, the detailed investigation should:

- adopt a structured and staged approach
- gather information based on clearly defined stages of investigation
- consider the immediate site and the adjacent area
- take into account the possibility of future development in the vicinity of the site
- consider the nature of the development
- consider the complexity of the ground conditions
- cover the extent of influence of the proposed foundations
- consider the presence of soil gas; if there is any possibility of gas being present, then a full gas investigation should be carried out, which should include flow measurements
- provide a clear understanding of the problems, and an understanding of the liabilities, which have to be managed in order to develop the site
- consider:
  - the surface water and ground water conditions
  - the soils and geology, and
  - the previous site history.

A consultant or specialist acceptable to NHBC should be appointed to:

- design and supervise the detailed investigation
- present all the factual data obtained from the detailed investigation.

Guidance for the appointment of a consultant or specialist is given in Appendix 4.1-D.

**FURTHER ASSESSMENT**

If the **detailed investigation** has not satisfactorily addressed all of the original objectives further investigation should be carried out.

**MANAGING THE RISKS**

**4.1 - D6 Any hazardous ground conditions shall be satisfactorily managed under the supervision of a consultant or specialist acceptable to NHBC**

As appropriate, the consultant or specialist acceptable to NHBC should:

- identify any results which show that design precautions and/or remediation may be necessary
- carry out a risk assessment to determine appropriate design precautions and/or remedial treatment
- specify the options for remediating any contamination that may be present and provide a remediation statement
- make recommendations as to appropriate design precautions including any ground improvement techniques as necessary
- make recommendations on appropriate precautions for all underground services serving the site
- ensure the works are appropriately supervised
- produce a remediation report.

Items to be taken into account include:

**DESIGN CONSIDERATIONS**

**(a) design precautions**

Solutions for dealing with geotechnical hazards include the following:

- specialist foundations:
  - piling and ground beams
  - rafts
- ground improvement techniques:
  - vibro
  - dynamic compaction
  - surcharging.

**(b) remediation techniques**

Solutions for dealing with contamination hazards include the following:

- risk avoidance - treatment to reduce the risk to the target by changing pathway or isolating the target by:
  - changing layout
  - building protective measures into construction

- engineering based - treatment to remove or isolate the contaminants or modify the pathway by:
  - excavation
  - providing ground barriers
  - covering and capping
- process based - treatment to remove, modify, stabilise or destroy the contaminants by:
  - physical means
  - biological means
  - chemical means
  - thermal means.

**(c) site location**

The identification of any constraints associated with the site and surrounding area which could restrict design precautions or remediation techniques should be identified and specified.

**(d) timescale**

Time constraints may influence the solution chosen since some techniques are very time consuming. This should not alter the requirement for effective remediation.

**(e) consultation**

In order to avoid abortive works it is important that the requirements of all statutory authorities are met by the proposed solution for the site.

**REMEDIATION**

**(f) method statement**

The method statement should detail the proposed remediation strategy for the site.

The statement should include the following details:

- original risk assessment, identification of the remediation objectives and outline information of the method chosen
- remediation objectives for ground, ground water and soil gas
- working method for implementation of the remediation
- waste classification and methods for controlling and disposing of waste
- proposed supervision and monitoring of remediation
- all validation sampling and testing to be implemented.

**(g) reports**

The report should include the following information:

- photographic records, especially for work which will be buried (e.g. membranes)
- site diaries or drawings, environmental supervisor's site diary, and independent witness statements where appropriate
- accurate surveys of the levels and position of all remediated areas
- a description of any remedial materials used
- details of soil movements and waste transfer notes
- results of post-remediation sampling; laboratory certificates should be provided in appendices

- validation test results
- monitoring results
- details of all consultations and meetings with statutory authorities.

**Now refer to Clause D7, Documentation and Verification.**

**All sites**

**DOCUMENTATION AND VERIFICATION**

**4.1 - D7 Documentation and verification shall be provided to the satisfaction of NHBC that the site is suitable for the proposed development**

Items to be taken into account include:

**(a) geotechnical assessment**

**WHERE GEOTECHNICAL HAZARDS ARE PRESENT**

NHBC should be provided with design proposals to overcome the hazards.

**(b) contamination assessment**

**WHERE CONTAMINATION HAZARDS ARE NOT PRESENT**

Evidence to substantiate that the site is not suspected to be hazardous may be asked for.

**WHERE CONTAMINATION HAZARDS ARE PRESENT**

NHBC should be provided with design proposals to overcome the hazards.

**Radon gas**

Where the site is within an area susceptible to radon it will be necessary to follow appropriate guidance in Building Regulations and associated documents.

The following table indicates the documentation required by NHBC.

# 4.1 Land quality - managing ground conditions

4.1

Documentation required by NHBC				
	No geotechnical or contamination hazards present	Geotechnical hazards present (but no contamination hazards)	Contamination hazards present (but no geotechnical hazards)	Geotechnical and contamination hazards present
Initial assessment, further assessment and basic investigation	✓	✓	✓	✓
Detailed investigation		✓	✓	✓
Proposals to manage geotechnical risks		✓		✓
Proposals to manage contamination risks			✓	✓
Verification evidence	✓	✓	✓	✓

## UNFORESEEN HAZARDS

**4.1 - D8 Where any additional or unforeseen ground conditions are found during construction, the builder shall ensure that they are investigated and managed to the satisfaction of NHBC**

As construction proceeds, additional or unforeseen hazards may be found. For example, it is possible to have undetected hazards which are missed by the site investigation.

Where additional or unforeseen hazards are found additional specialist advice is required so that the hazard is properly investigated, managed and verified.

## APPENDIX 4.1-A

### References

<p>BRE: Report BR211 - 'Radon: Guidance on protective measures for new dwellings'</p> <p>Report BR212 - 'Construction of new buildings on gas-contaminated land'</p> <p>Report BR376 - 'Radon: guidance on protective measures for new dwellings in Scotland'</p> <p>Report BR413 - 'Radon: guidance on protective measures for new dwellings in Northern Ireland'</p> <p>Report BR414 - 'Protective measures for housing on gas-contaminated land'</p> <p>Digest 383 - 'Site investigation for low-rise buildings: Soil description'</p> <p>BSI: BS EN 1997-2- Geotechnical design: Ground investigation and testing</p> <p>BS 10175 - Investigation of potentially contaminated sites</p> <p>BS EN ISO 14688 - Geotechnical investigation and testing. Identification and classification of soil: Part 1. Identification and description. Part 2. Principles for a classification.</p> <p>BS EN ISO 22476 - Geotechnical investigation and testing. Sampling methods and groundwater measurements. Part 1. Technical principles for execution.</p> <p>BS 8485 - Code of practice for the characterization and remediation of ground gas in affected development.</p> <p>CIRIA: C665 - Assessing risks posed by hazardous ground gasses to buildings.</p> <p>Special publications 101 - 112 - Remedial treatment for contaminated land</p>	<p>DCLG and its predecessor departments</p> <p>Approved Documents A and C - Structures and site preparation and resistance to contaminants and moisture</p> <p>DEFRA and its predecessor departments</p> <p>CLAN 02/05 Soil guideline values and the determination of land as contaminated land under Part 2A</p> <p>Circular 01/2006 Environmental Protection Act 1990: Part 2A Contaminated Land</p> <p>Department of the Environment Industry Profiles - Information on the processes, materials and wastes associated with individual industries</p> <p>Department of the Environment - Waste Management Paper No 27 - Landfill Gas: A technical memorandum on the monitoring and control of landfill gas.</p> <p>Environment Agency</p> <p>CLR11 Model procedures for the management of land contamination</p> <p>CLEA (Contaminated Land Exposure Assessment) guidance and software Science Reports SR 1,2,3 and 7.</p> <p>NHBC: Guidance on evaluation of development proposals on sites where methane and carbon dioxide are present.</p> <p>R&amp;D Publication 66 - Guidance for the safe development of housing on land affected by contamination.</p>
---	---

## APPENDIX 4.1-B

## Examples of potential hazards and associated risks

Potential hazard	Associated risk
High water table or low lying land	Flooding. Effects from toxic or noxious materials which could be concentrated or transported by ground water.
Mining, past, present and proposed	Ground movement which will depend on the type of workings and materials extracted. Existence of ground gasses including methane and carbon dioxide.
Solution features in chalk and limestone including swallow holes	Underground cavities.
Trees	Shrinkage and heave of clay soils. See Technical Requirement R5. Physical damage caused by roots.
Peat	Acid attack. Changes in volume due to variations in moisture content. Production of methane and carbon dioxide.
Low bearing capacity ground	Settlement of foundations and sub-structures.
Infill and made ground including tipping	Release of gases which may be explosive or asphyxiating. Low bearing capacity causing settlement.
Former buildings or structures	Underground obstructions producing variations in bearing capacity and settlement characteristics.
Adjacent buildings	Effect on stability of both the new and existing buildings.
Existing drains, including land drains	Contamination, flooding, waterlogging and interruption of land drainage systems.
Sulfates in ground or ground water	Expansive reaction. Chemical attack on concrete, mortar and bricks or blocks made with cement.
Unstable ground subject to landslip	Ground movement.
Seas, lakes and rivers adjacent to land	Erosion.
Contamination	Substances which may be: <ul style="list-style-type: none"> <li>• carcinogenic</li> <li>• toxic</li> <li>• asphyxiating</li> <li>• corrosive</li> <li>• phytotoxic</li> <li>• combustive</li> <li>• explosive</li> <li>• radioactive.</li> </ul>

## APPENDIX 4.1-C

**Site investigation techniques**

(In accordance with the recommendations of BS EN 1997-2 Geotechnical design: Ground investigation and testing)

Site investigation normally comprises a combination of the following:

**Direct investigation**

These techniques involve intrusive activities to enable retrieval and examination of the ground using the following methods of investigation:

**a) trial pits**

Trial pits allow the detailed inspection, logging, sampling and in-situ testing of large volumes of natural soil or fill and the assessment of ground water conditions.

**b) trenches**

Trenches are extended trial pits or linked trial pits which are excavated where greater exposure of the ground conditions is required.

Trial pits and trenches should be positioned where they will not affect future foundations.

**c) boreholes**

- Light cable percussion drilling  
The conventional equipment used in the UK to drill boreholes in soils and weak rocks is the light cable percussion rig, often referred to as the shell and auger rig.
- Continuous flight auger  
Exploratory boreholes may also be drilled in soils by mechanical continuous flight augers of various sizes. Hollow stem methods are typically employed where sample retrieval is required.
- Rotary drilling  
Rotary drilling is used to investigate rock and sometimes stiff soils such as Boulder Clay. The two basic rotary methods are open-hole drilling and rotary coring.

**d) probes**

Probing techniques can be used for the analysis of the relative density of soils and also for environmental sampling and monitoring (such as chemical and physical testing of gases, liquids and solids).

**Indirect investigation**

Geophysical techniques (for example, electromagnetic, resistivity, seismic, gravity and ground radar) provide indirect interpretations of ground conditions. These measure from the surface, variations in properties of the ground both horizontally and vertically and hence attempt to define subsurface conditions.

Geophysical methods rely for their effectiveness on marked contrasts in the physical properties being measured. The required contrasts are provided by boundaries between distinctive strata with different properties (for example, between sand and gravel and rockhead). Definable contrasts may also be provided by faulting, underground cables and pipelines or by cavities.

**Sampling**

The number and type of samples taken and tests which are carried out for any particular investigation are designed to be appropriate to the range of ground materials encountered and to the development which is planned. The requirements should take account of the results of the desk study, the walkover survey and the site investigation.

Samples should always be taken, stored and transported carefully to avoid cross contamination.

Samples can be taken of:

**a) soils and rocks**

Samples from trial pits and boreholes are taken to enable soil and rock descriptions to be made and to provide material for physical and chemical testing.

Samples of soils may be either 'disturbed' (that is, not retaining the original structure and consistency) or 'undisturbed'. Having undergone minimal disturbance, it follows that 'undisturbed' samples provide a more reliable indication of physical soil properties than 'disturbed' samples.

**b) ground water**

Ground water should be collected from appropriately designed monitoring wells. The wells should be screened and sealed to ensure that the relevant stratum is being monitored.

**c) gas**

Gas sampling should be carried out from appropriately designed monitoring wells. Boreholes or window sampling holes are typically used. Identification of likely source and measurement of gas flows plays an important role in assessment of risk.

**Testing****a) in-situ testing**

A wide variety of in-situ tests can be used to support the results of direct testing. These range from basic tests undertaken by geologists or engineers using simple hand-held devices or portable test kits to the more elaborate methods that require specialist personnel and equipment.

**b) laboratory testing**

Testing laboratories should participate in quality assurance programmes (such as Contest and Aquacheck) and be

accredited for relevant tests (by the likes of UKAS and MCERTS).

Physical tests on soil and rock materials are carried out to provide the following information on ground:

- strength
- relative density
- deformation
- settlement
- consolidation characteristics
- permeability.

Chemical tests on soils, rocks, ground water and gases can be carried out to provide an indication of potential contamination on the site.



**APPENDIX 4.1-D**

**“Suitable persons” and “consultants or specialists”**

**SUITABLE PERSONS**

The following skills and knowledge are required by the person responsible for the Initial Assessment (Clause D3), Basic Investigation (Clause D4) and Documentation and Verification (Clause D7):

- be able to carry out a desk study and walkover survey
- understand the hazards that can affect the development and know from where they originate
- know how to collect information relating to such hazards on and adjacent to the site
- be able to recognise the signs of potential hazards
- be able to determine when specialist advice and detailed testing is required, and
- be able to report the findings in a clear and concise manner.

**CONSULTANTS OR SPECIALISTS**

The following criteria should be used as guidance for the appointment of a consultant or specialist responsible for the Detailed Investigation (Clause D5), management of hazards (Clause D6) and Documentation and Verification (Clause D7):

Experience	has experience with similar types of site and development
Appropriate discipline(s)	a thorough understanding of all the relevant skills required on the project and has access to the skills of other disciplines including chemists, geologists, hydrogeologists, toxicologists and environmental chemists
Project management	ability to manage a project team consisting of the appropriate disciplines
Communication	able to communicate effectively within their organisation, with the client, statutory authorities and the general public
Reporting	can prepare comprehensive and well presented reports
Legislation	understands the legislation and liabilities associated with the area of the United Kingdom in which the development is being carried out
Quality assurance	has an appropriate quality management system and uses appropriately accredited laboratories
Risk management	can carry out risk assessments as part of the risk management process
Site investigation	can design site investigation programmes which include soil sampling, testing and laboratory analysis
Health and safety	is fully aware of all occupational hygiene issues and health and safety legislation
Engineering design	understands effective risk reduction techniques e.g. engineered foundations and sub-structure details or suitable remediation
Professional indemnity insurance	has, and maintains, appropriate Professional Indemnity Insurance for the work being carried out.

4.1

**INDEX**

<b>A</b>		<b>H</b>		<b>S</b>	
Assessment	1	Hazards	1, 3, 4, 5, 6, 7, 8, 9	Site investigation techniques	8
<b>B</b>		<b>I</b>		Source	1
Basic investigation	1, 4, 9	Initial assessment	1, 3, 4, 9	Specialist	4, 5, 9
<b>C</b>		<b>O</b>		Suitable person	3, 4, 9
Consultant	5, 9	Objectives	1	Supervision	4, 5
Contamination	5	<b>P</b>		<b>U</b>	
Contamination hazards	4, 5, 7	Pathway	1	Unforeseen hazards	2, 9
<b>D</b>		Potential hazards	7	<b>V</b>	
Design considerations	5	Procedural flow chart	1, 2	Verification	2, 9
Desk study	1, 3, 4, 9	Procedural summary	1	<b>W</b>	
Detailed investigation	1, 4, 9	<b>R</b>		Walkover survey	2, 4, 5, 9
Documentation	1, 5, 6, 9	Receptor	1		
<b>F</b>		Remediation	5		
Further assessment	1, 4	Results	1, 4, 5, 8, 9		
Further investigation	1, 4				
<b>G</b>					
Geotechnical hazards	5, 6				





# Chapter 4.2

## Building near trees

---



# 4.2 Building near trees

## CONTENTS

	Clause	Page
<b>INTRODUCTION</b>		1
<b>DESIGN</b>		
Design standards	D1	1
Statutory requirements	D2	1
Trees and hedgerows adjacent to structures	D3	1
Foundations (all soil types)	D4	1
Foundations (shrinkable soils)	D5-D7	1 - 3
Designing to accommodate heave	D8	4
Provision of information	D9	5
<b>MATERIALS</b>		
Materials standards	M1	5
Proprietary heave materials	M2	5
<b>SITWORK</b>		
Sitework standards	S1	5
Foundation depths	S2	5
Excavation for foundations	S3	6
Heave precautions	S4	6
Drainage	S5	7
<b>APPENDIX 4.2-A</b>		
Water demand and mature height of trees		8
<b>APPENDIX 4.2-B</b>		
Foundation depth charts		9
<b>APPENDIX 4.2-C</b>		
Foundation depth tables		13
<b>APPENDIX 4.2-D</b>		
Climate zones		19
<b>APPENDIX 4.2-E</b>		
Information sources and acknowledgements		20
<b>APPENDIX 4.2-F</b>		
Worked example		21
<b>INDEX</b>		23

## SCOPE

This Chapter gives guidance on meeting the Technical Requirements and recommendations when building near trees, hedgerows and shrubs, particularly in shrinkable soils.

## INTRODUCTION

The combination of shrinkable soils and trees, hedgerows or shrubs represents a hazard to structures that requires special consideration. Trees, hedgerows and shrubs take moisture from the ground and, in cohesive soils such as clay, this can cause significant volume changes resulting in ground movement. This has the potential to affect foundations and damage the supported structure. In order to minimise this risk, foundations should be designed to accommodate the movement or be taken to a depth where the likelihood of damaging movement is low.

This Chapter gives guidance for common foundation types to deal with the hazard and includes suitable foundation depths which have been established from field data, research, NHBC data and practical experience. The depths are not those at which root activity, desiccation and ground movement are non-existent but they are intended to provide an acceptable level of risk. However, if significant quantities of roots are unexpectedly encountered in the base of the trench, the excavation may need to be deepened.

The interaction between trees, soil and buildings is dependent on many factors and is inherently complex. The relationship becomes less predictable as factors combine to produce extreme conditions. These are signified by the need for deeper foundations. Depths greater than 2.5m indicate that conditions exist where prescriptive guidance is less reliable.

The following situations are beyond the scope of the guidance in this Chapter and will require a site specific assessment by an Engineer (see Technical Requirement R5):

- foundations with depths greater than 2.5m within the influence of trees
- ground with a slope of greater than 1 in 7 (approximately 8°) and man made slopes such as embankments and cuttings
- underpinning.

Consideration has been given to the potential effects of climate change in the guidance provided.

The services of a specialist arboriculturalist may be helpful for the identification of the type and condition of trees that may affect building work. This includes trees both on and adjacent to the site.

## DESIGN STANDARDS

### 4.2 - D1 Design shall meet the Technical Requirements

Design that follows the guidance below will be acceptable for building near trees, hedgerows and shrubs.

## STATUTORY REQUIREMENTS

### 4.2 - D2 Design shall comply with all relevant statutory requirements

Design should be in accordance with relevant Building Regulations and other statutory requirements.

## TREES AND HEDGEROWS ADJACENT TO STRUCTURES

### 4.2 - D3 The design shall take account of trees and hedgerows and their growth

Items to be taken into account include:

#### (a) removal of existing trees and hedgerows

Dead trees and dead hedgerows should be removed. Unstable trees should be made stable but where this is not possible they should be felled. If in doubt, advice should be obtained from a Registered Arboriculturalist.

Acts of Parliament, planning conditions, conservation area restrictions or tree preservation orders may mean that trees and hedgerows are protected and must be retained. The local planning authority should be consulted.

#### (b) protection of remaining trees and hedgerows

Most of a tree's root system is within 600mm of the surface and extends radially for distances often in excess of the tree's height. All parts of the root system are vulnerable to damage and once damaged, roots may not regenerate. Extensive root damage may impair the stability of the tree.

Root damage and tree instability can be caused by:

- stripping topsoil too close to trees
- excavating trenches for foundations and services too close to trees
- raising soil levels adjacent to trees, particularly where non-granular materials are used
- compaction of soil around trees by heavy plant
- storage of heavy materials around trees
- covering rooting area with impervious surfaces.

Trees should be protected from damage by:

- a fence or barrier. The fence or barrier should extend around a single trunk equivalent to a circle of radius 12 times the trunk diameter measured 1.5m above ground level. The shape of this area may

change depending on specific factors such as local drainage, soil type, age and species of the tree. An arboriculturist may be required to assess these factors

- ensuring services are not routed close to trees or, where this is impractical, are installed in such a way as to minimise root damage.

Further guidance is given in BS 5837.

#### (c) allowance for physical growth of young trees

Direct damage due to the growth of the main trunk and roots of young trees should be avoided by locating structures and services at a safe distance from the trees. Further guidance is given in BS 5837. Where this cannot be achieved precautions should be taken to allow for future growth. For example:

- foundations should be reinforced to resist lateral forces
- walls or structural slabs should bridge over the roots allowing sufficient clearance for future growth or be reinforced to avoid cracking
- pavings and other surfaces should be laid on a flexible base to allow for some movement.

## FOUNDATIONS (all soil types)

### 4.2 - D4 Foundations for all soil types shall be designed to transmit loads to the ground safely and without excessive movement

Foundations for all soil types should be designed and constructed in accordance with Chapter 4.1 'Land quality - managing ground conditions' and other relevant Chapters of the Standards (depending on site specific conditions).

Different foundation types should not be used to support the same structure unless the foundations and superstructure design are undertaken by an Engineer (see Technical Requirement R5).

The remainder of this Chapter gives additional guidance that applies when building near trees, hedgerows and shrubs on shrinkable soils as defined in Clause D5(b).

## Foundations (shrinkable soils)

### 4.2 - D5 The design shall make allowance for the effect of trees and hedgerows on shrinkable soils

Items to be taken into account include:

#### (a) shrinkage and heave

Shrinkable soils are subject to changes in volume as their moisture content is altered. Soil moisture contents vary seasonally and are influenced by a number of factors including the action of tree roots. The resulting shrinkage or swelling of the soil can cause subsidence or heave damage to foundations, the structures

they support and services. Heave precautions are described in Clause D8.

Shrinkable soils are widely distributed throughout the UK. Local geological survey maps may give relevant information.

#### (b) soil classification

For the purposes of this Chapter, shrinkable soils are those containing more than 35% fine particles and having a modified Plasticity Index of 10% or greater.

Fine particles are defined as those having a nominal diameter less than 60µm, ie. clay and silt particles.

The Plasticity Index (Ip) of a soil is a measure of its volume change potential and is determined by Atterberg Limits tests. These tests are carried out on the fine particles and any medium and fine sand particles. Soil particles with a nominal diameter greater than 425µm are removed by sieving beforehand. The percentage of particles smaller than 425µm is routinely reported for Atterberg Limits tests. This is a requirement of BS 1377, which specifies the test procedure.

The Modified Plasticity Index (I'p) is defined as the Plasticity Index (Ip) of the soil multiplied by the percentage of particles less than 425µm.

$$\text{i.e. } I'p = Ip \times \frac{\% \text{ less than } 425\mu\text{m}}{100\%}$$

Modified Plasticity Index is related to volume change potential as shown in Table 1.

**Table 1 Volume change potential**

Modified Plasticity Index	Volume change potential
40% and greater	High
20% to less than 40%	Medium
10% to less than 20%	Low

Alternatively the Plasticity Index may be used without modification. For pure clays and other soils with 100% of particles less than 425µm the result will be the same. However, for mixed soils such as glacial tills, use of the modified Plasticity Index may result in a more economic design.

For further information about the modified Plasticity Index refer to BRE Digest 240.

The volume change potential should be established from site investigation and reliable local knowledge of the geology.

Sufficient samples should be taken to provide confidence that the test results are representative of the soil volume change potential for the site. If in doubt use the higher value of volume change potential.

If the volume change potential is unknown, high volume change potential should be assumed.

# 4.2 Building near trees

## (c) water demand of trees

Water demand varies according to tree species and size.

Appendix 4.2-A gives the water demand categories of common tree species.

Where the species of a tree has not been identified, high water demand should be assumed.

Where the species of a tree has been identified but is not listed, the following assumptions may be made for broad leafed trees:

- high water demand - all Elms, Eucalyptus, Hawthorn, Oaks, Poplars and Willows
- moderate water demand - all others.

Where trees are not listed in Appendix 4.2-A, information may be obtained from suitable alternative authoritative sources (see Appendix 4.2-F).

Tree identification can be assisted by reference to a tree recognition book (see Appendix 4.2-F).

For the purposes of this Chapter, the zone (i.e. lateral extent) of influence of trees is shown in Table 2.

**Table 2 Zone of tree influence**

Water demand	Zone of influence
High	1.25 x mature height
Moderate	0.75 x mature height
Low	0.5 x mature height

## (d) tree heights

Mature heights of common tree species are listed in Appendix 4.2-A. For the purposes of this Chapter, these are the average mature heights to which healthy trees of the species may be expected to grow in favourable ground and environmental conditions. These may be used even when the actual heights are greater.

The mature heights given in Appendix 4.2-A should be used for trees that are to remain or are scheduled to be planted and where ground levels are unaltered. Where ground levels are increased see also Figure 1 and Sitework clause S3(c).

Where there are different species within hedgerows, the mature height of the species likely to have the greatest effect should be used.

For trees which have been or are to be removed, allowance should be made for the fact that the water demand of a tree varies with its size and rate of growth (see Figure 1). The water demand of a semi-mature tree may be as great as that for a mature tree of the same species whereas the water demand for a sapling or young tree will be significantly less.

**Figure 1 Tree height H to be used for particular design cases**

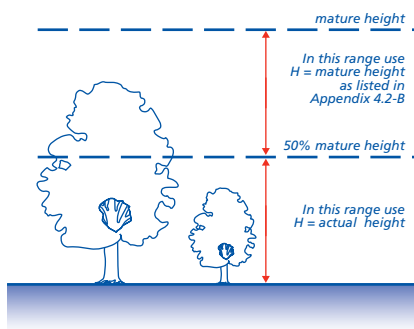

Figure 1 should be used when:

- deriving foundation depths when trees have been removed (use tree height at time of removal - see Design clause 4.2 - D5(a))
- checking the appropriate level from which depths should be measured when trees remain and ground levels are increased (use tree height at time of construction relative to original ground level - see Figure 5)
- determining whether heave precautions should be provided (use tree height at time of construction - see Design clause 4.2 - D8(b) and (c)).

Where trees have undergone or are to undergo heavy crown reduction or pollarding, the mature height should be used or a Registered Arboriculturalist should be consulted to undertake a site specific assessment.

## (e) climate

High rainfall reduces moisture deficits caused by trees and hedgerows, and cool damp weather reduces the rate of water loss from the tree, thus reducing the risk of soil movement. As the driest and hottest conditions in the UK usually prevail in southeast England, the greater risk occurs in that area and diminishes with distance north and west.

For the purposes of this Chapter, the UK has been divided into zones at 50 mile intervals from London. After the foundation depth has been derived from Appendix 4.2-B or 4.2-C a reduction of 0.05m (50mm) may be made for every 50 miles distance north and west of London (see Appendix 4.2-D).

## 4.2 - D6 Foundations shall be capable of accommodating the effects of trees and hedgerows on shrinkable soils without excessive movement

Items to be taken into account include:

### (a) foundations

Foundations to all permanent structures (including garages, porches and conservatories) should take account of the effects of soil desiccation caused by previous or existing trees and trees which are scheduled to be planted.

The following foundations will be acceptable in shrinkable soils, provided that they are capable of supporting the applied loads without undue settlement, heave precautions are taken as in Clause D8 and their design takes account of

Clause D7:

- strip
- trench fill
- pier and beam
- pile and beam
- raft.

Variations to the foundation depths derived from this Chapter may be permitted where other foundation depths are traditionally acceptable or where necessary to take account of local ground conditions, provided that they can be supported by a design in accordance with Technical Requirement R5.

Root barriers are not a reliable means of reducing the effects of trees on foundations in shrinkable soils and are not an acceptable alternative to the guidance given in this Chapter.

Freestanding masonry walls should be constructed on foundations in accordance with this Chapter or be designed to accommodate likely ground movement, for example, by careful use of movement joints and reinforcement.

## (b) method of assessment of foundation depths

One of the following methods may be used:

- design in accordance with this Chapter to a depth derived from Appendix 4.2-B or 4.2-C taking account of:
  - the site investigation
  - the soil volume change potential
  - the water demand of the tree
  - the appropriate tree height
  - the distance of the tree(s) from the foundations
  - the geographical location of the site north and west of London
  - appropriate heave precautions.

Note: the most onerous conditions should be assumed in the absence of any of the above information.

- design by an Engineer in accordance with Technical Requirement R5, taking account of:
  - the recommendations of this Chapter
  - results of the site investigation
  - advice, when necessary, from a Registered Arboriculturalist or other competent person whose qualifications are acceptable to NHBC.

Note: when this method is used and it results in foundation depths or other details less onerous than those derived from this Chapter, the design should be submitted to NHBC for approval prior to work commencing on site.

## (c) distance between tree and foundation

The distance D between the centre of the trunk and the nearest face of the foundation should be used to derive the foundation depths from Appendix 4.2-B or 4.2-C.

For trees which have been or are to be removed from within 2m of the face of the proposed foundation and where the height on removal is less than 50% of the mature height given in Appendix 4.2-A, it may be assumed that  $D = 2m$ .

Note: This is to avoid the anomalous situation where, for example, a "sapling" removed from the foundation line would otherwise require an unnecessarily deep foundation since the D/H value would always be zero regardless of the height H of the tree.

#### (d) foundation depths related to proposed tree planting

Foundation depths relating to proposed tree planting should be based on one of the following:

- foundation depths derived in accordance with Appendix 4.2-B or 4.2-C, or
- foundation depths shown in Table 3 with limits agreed in the planting schedules to exclude trees within the distances from foundations shown in Table 4, or
- foundation depths shown in Table 5 with limits agreed in the planting schedules to exclude trees within the zone of influence shown in Table 2.

**Table 3 Minimum foundations depths allowing for restricted new planting**

Volume change potential	Minimum depth [m]
High	1.5
Medium	1.25
Low	1.0

**Table 4 No tree planting zone for minimum depth foundations**

Water demand	No tree planting zone
High	1.0 x mature height
Moderate	0.5 x mature height
Low	0.2 x mature height

**Table 5 Minimum foundations depths outside zone of influence**

Volume change potential	Minimum depth [m]
High	1.0
Medium	0.9
Low	0.75

Planting schedules should be agreed with the local planning authority before work commences on site.

The landscape and foundation designs should be compatible.

#### (e) foundation depths related to new shrub planting

Shrubs have considerable potential to cause changes in soil moisture content.

The foundation design should consider shrub planting as follows:

- Shrubs whose mature height does not exceed 1.8m and climbing varieties (i.e. those requiring a wall for support) whose mature height does not exceed 5m:
  - use foundation depth from Table 5
- Pyracantha and Cotoneaster whose mature height exceeds 1.8m:
  - use foundation depth from Table 5 and plant at least 1.0 x mature height from foundation, or
  - use foundation depth from Table 3 and plant at least 0.5 x mature height from foundation
- All others:
  - use foundation depth from Table 5 and plant at least 0.75 x mature height from foundation, or
  - use foundation depth from Table 3 - no restriction on minimum distance from foundation.

Planting schedules should be produced by a qualified landscape architect or other suitably qualified person and agreed with the local planning authority before work commences on site.

The landscape and foundation designs should be compatible.

Table 6 - removed April 2005

#### (f) strip or trench fill foundations in non shrinkable soils overlying shrinkable soil

Non shrinkable soils such as sands and gravels may overlie shrinkable soil.

Foundations may be constructed on the overlying non shrinkable soil in accordance with Chapter 4.4 'Strip and trench fill foundations' provided all of the following conditions are satisfied, as illustrated in Figure 2:

- consistent soil conditions exist across each plot. This should be confirmed by the site investigation
- the depth of the non shrinkable soil is greater than  $3/4$  depth X, where X is the foundation depth determined using Appendix 4.2-B or 4.2-C, assuming that all the soil is shrinkable
- the thickness T of non shrinkable soil below the foundation is equal to or greater than the width of the foundation B
- the proposals are submitted to and approved by NHBC prior to work commencing on site.

Where any of the above conditions is not met, foundation depths should be determined as for shrinkable soil.

**Figure 2 Foundations in non shrinkable soils overlying shrinkable soil**

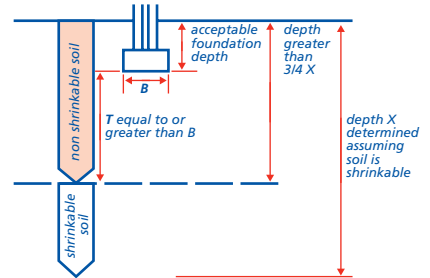

#### (g) stepped foundations

Where foundations are to be stepped to take account of the influence of trees, hedgerows and shrubs they should be stepped gradually in accordance with Chapter 4.4 'Strip and trench fill foundations' with no step exceeding 0.5m (see Sitework clause S3(b)).

#### (h) foundations on or near sloping ground

Where the foundations are on or adjacent to sloping ground greater than 1 in 7 (approximately 8°) and man-made slopes such as embankments and cuttings they should be designed by an Engineer (see Technical Requirement R5).

Items to be taken into account include:

- slope stability
- potentially enhanced desiccation due to increased run-off and the de-watering effects of the slope and vegetation.

#### 4.2 - D7 Foundations in shrinkable soils shall be designed to transmit loads to the ground safely and without excessive movement

Items to be taken into account include:

##### (a) strip foundations

Strip foundations up to 1.5m deep should be constructed in accordance with the recommendations of this Chapter and Chapter 4.4 'Strip and trench fill foundations'. Depths should be determined in accordance with Clause D6.

##### (b) trench fill foundations

Trench fill foundations up to 2.5m deep should be constructed in accordance with the recommendations of this Chapter and Chapter 4.4 'Strip and trench fill foundations'. Depths should be determined in accordance with Clause D6.

Reference should be made to Clause D8 to establish the precautions necessary to cater for potential heave.

Trench fill foundations deeper than 2.5m will only be acceptable if they are designed by an Engineer (see Technical Requirement R5) taking account of all potential movement of the soil on the foundations and substructure.



# 4.2 Building near trees

4.2

The following will need to be taken into account if foundations are to be deeper than 2.5m:

- foundation depths should be designed taking account of soil desiccation and arboricultural advice
- additional heave precautions may be necessary to cater for lateral and shear forces acting on large vertical areas of foundation
- instability of the trench sides can lead to serious construction difficulties
- the foundation is dependent upon a high level of workmanship and detailing:
  - concrete overspill or overbreak in the excavations can result in additional vertical forces being transmitted to the foundation
  - construction joints will need to be detailed to take account of the increased lateral forces
  - compressible material should be correctly placed to avoid excessive heave forces being applied to the foundation.

### (c) pier and beam foundations

Pier and beam foundations should be designed by an Engineer (see Technical Requirement R5) and constructed in accordance with the recommendations of this Chapter and Chapter 4.5 'Raft, pile, pier and beam foundations'.

Note: pier depths up to 2.5m may be derived from Clause D6. Pier depths greater than 2.5m require site specific assessment.

Reference should be made to Clause D8 to establish the precautions necessary to cater for potential heave.

### (d) pile and beam foundations

Pile and beam foundations should be designed by an Engineer (see Technical Requirement R5) and constructed in accordance with the recommendations of this Chapter and Chapter 4.5 'Raft, pile, pier and beam foundations'.

Reference should be made to Clause D8 to establish the precautions necessary to cater for potential heave.

### (e) raft foundations

Raft foundations should be designed by an Engineer (see Technical Requirement R5) and constructed in accordance with the recommendations of this Chapter, Chapter 4.5 'Raft, pile, pier and beam foundations' and the following conditions.

Raft foundations will only be acceptable where all of the following apply, as illustrated in Figure 3:

- the foundation depth derived in accordance with Clause D6 is 2.5m or less
- the raft is founded on granular infill placed and fully compacted in layers in accordance with the Engineer's specification and to NHBC's satisfaction.

- The infill should not be less than 50% of the foundation depth derived in accordance with Clause D6 and should not exceed 1.25m. Site inspections by the Engineer may be required by NHBC to verify the compaction of the fill
- the infill extends beyond the edge of the foundation by a distance equal to the natural angle of repose of the infill plus 0.5m
- the raft is generally rectangular in plan with a side ratio of not more than 2:1
- NHBC is satisfied that the raft is sufficiently stiff to resist differential movements.

**Figure 3 Requirements for raft foundations on shrinkable soils**

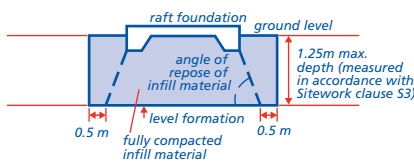

## DESIGNING TO ACCOMMODATE HEAVE

### 4.2 - D8 Foundations, substructure and services shall incorporate adequate precautions to prevent excessive movement due to heave

Heave can take place in a shrinkable soil when it takes up moisture and swells after the felling or removal of trees and hedgerows. It can also occur beneath a building if roots are severed or if water enters the ground from leaking drains, water services or changes in ground water conditions.

Items to be taken into account include:

#### (a) vegetation survey

Before the site is cleared, the location, heights and species of trees, hedgerows and shrubs on and adjacent to the site and which may affect proposed foundations should be surveyed and recorded.

If the location of previously removed vegetation is not known, local enquiries and reference to aerial photographs may be necessary. Otherwise the design should assume the worst conditions or an Engineer (see Technical Requirement R5) should be consulted to undertake a site specific design based on all relevant information.

Where root growth is noted within shrinkable soil and where records are not available, an Engineer (see Technical Requirement R5) should be consulted to assess whether heave is likely.

#### (b) heave precautions for trench fill foundations

Trench fill foundations should be designed in accordance with Clause D7. Any foundations deeper than 2.5m should be designed by an Engineer (see Technical Requirement R5).

Heave precautions should be used:

- where the foundation is within the zone of influence of trees (see Table 2), and
- where the foundation depth determined in accordance with Clause D6 is greater than 1.5m based on the appropriate tree height (see Figure 1).

Heave precautions for trench fill foundations up to 2.5m should be in accordance with Sitework clause S4(a).

#### (c) heave precautions for pier and beam foundations

Pier and beam foundations should be designed in accordance with Clause D7.

Heave precautions for piers should be used:

- where the foundation is within the zone of influence of trees (see Table 2), and
- where the foundation depth derived in accordance with Clause D6 is greater than 1.5m based on the appropriate tree height (see Figure 1).

Heave precautions for pier and beam foundations should be in accordance with Sitework clause S4(b).

#### (d) heave precautions for pile and beam foundations

Pile and beam foundations should be designed in accordance with Clause D7.

Heave precautions should be used for piles and ground beams in accordance with Sitework clause S4(c). In addition the following should be taken into account in the selection and design of piles:

- piles should be designed with an adequate factor of safety to resist uplift forces on the shaft due to heave by providing sufficient anchorage below the depth of desiccated soil. Slip liners may be used to reduce the uplift but the amount of reduction is small, as friction between materials cannot be eliminated
- piles should be reinforced for the length of the pile governed by the heave design
- bored, cast-in-place piles are well suited to this application. Most types have a straight-sided shaft but some construction techniques produce a contoured shaft, similar to a screw profile, to increase load capacity. The design should allow for the enhanced tensile forces in such piles
- driven piles are less well suited to this application and are difficult to install in stiff desiccated clay without excessive noise and vibration. Most types are jointed and, if these are to be used, the joint design should be capable of transmitting tensile heave forces
- piles and ground beams should be designed taking into account the upward force on the underside of the ground beams transmitted through the compressible material or void former prior to collapse (refer to manufacturer's data).

### (e) suspended ground floors

Suspended ground floors should be used in all situations where heave can occur within the area bounded by the foundations. This includes:

- where the foundation depth derived in accordance with Clause D6 is greater than 1.5m based on the appropriate tree height (see Figure 1), unless NHBC is satisfied the soil is not desiccated
- where ground floor construction is undertaken when surface soils are seasonally desiccated (i.e. during summer and autumn) unless NHBC is satisfied the soil is not desiccated.

The following types of suspended floor will be acceptable where there is potential for heave.

### PRECAST CONCRETE

A minimum void depth should be provided between underside of beam and ground level as shown in Table 10 (see Sitework clause S4(d)).

### TIMBER

A minimum void depth should be provided between underside of joist and ground level as shown in Table 10 (see Sitework clause S4(d)). All sleeper walls should have foundations with depths derived in accordance with Clause D6.

### IN-SITU CONCRETE

A minimum void depth should be provided between the ground and the underside of slab as shown in Table 9 (see Sitework clause S4(d)). Where proprietary materials are used, they should be in accordance with Materials clause M2 and the design should take into account the upward force transmitted through the compressible material or void former prior to collapse (refer to manufacturer's data).

### (f) heave precautions for raft foundations

Raft foundations constructed in accordance with Clause D7 should provide adequate protection from heave.

### (g) other foundations

All foundations not covered in the above clauses, but specifically designed for heave, should be designed by an Engineer (see Technical Requirement R5) taking account of the recommendations of this Chapter and submitted to NHBC for approval prior to work commencing on site.

### (h) heave precautions for new drains

Drainage should be constructed in accordance with Chapter 5.3 'Drainage below ground' with the following additional precautions to guard against the effects of heave:

- design gradients may need to be greater than the minimum gradients in Chapter 5.3 as these do not allow for possible ground movement. Where sufficient falls to cater for the likely movement cannot be provided, alternative means

of catering for the movement should be used, for example taking the excavation deeper and laying the pipework on granular bedding of suitable thickness to reduce the extent of potential movement

- a drainage system capable of accommodating the likely movement should be used
- pipes and services passing through substructure walls or trench fill foundations should be designed and detailed so as to cope with the potential ground movements shown in Table 7.

**Table 7 Potential ground movement**

Volume change potential	Potential ground movement [mm]
High	150
Medium	100
Low	50

Existing land drains should be maintained or diverted. Where the void beneath suspended floors is liable to flooding, drainage should be provided.

### (i) paths and driveways

Drives and pathways should be designed and detailed to cater for the likely ground movement.

Further guidance is given in BS 5837.

## PROVISION OF INFORMATION

**4.2 - D9 Designs and specifications shall be produced in a clearly understandable format and all relevant information shall be distributed to appropriate personnel**

It is important that all relevant information needed for the completion of the sitework is readily available to all appropriate personnel.

All necessary dimensions and levels should be indicated and related to:

- at least one benchmark, and
  - reference points on site.
- Details should be provided with respect to:
- site investigation
  - site survey including location and height of trees and hedgerows affecting the site
  - site layout
  - dimensions, type and depth of foundations
  - soil volume change potential
  - tree species (including existing, removed and proposed) using English names
  - planting schedules
  - original and final ground levels
  - technical method statements including critical sequences of construction
  - location of services
  - design of drainage system
  - locations and detailing of:
    - steps in foundations
    - movement and construction joints
    - ducts and services passing through the foundations.

## MATERIALS STANDARDS

**4.2 - M1 All materials shall: (a) meet the Technical Requirements (b) take account of the design**

Materials that comply with the design and the guidance below will be acceptable for building near trees.

Materials used when building near trees should comply with all relevant standards, including those listed below. Where no standard exists, Technical Requirement R3 applies (see Chapter 1.1 'Introduction to the Standards and Technical Requirements').

References to British Standards and Codes of Practice include those made under the Construction Products Directive (89/106/EEC) and, in particular, appropriate European Technical Specifications approved by a European Committee for Standardisation (CEN).

## PROPRIETARY HEAVE MATERIALS

**4.2 - M2 Proprietary heave materials shall be assessed in accordance with Technical Requirement R3**

Where foundations and substructure could be subjected to heave, they should be protected by voids, void formers or compressible materials in accordance with the design.

Void formers consist of material that collapses to form a void into which the clay can swell reducing the build up of load on the foundation.

Compressible material, such as low density polystyrene, compacts as the clay expands reducing the build up of load on the foundation.

Each material should be used in accordance with the requirements of the relevant independent assessment and the manufacturer's recommendations.

## SITWORK STANDARDS

**4.2 - S1 All sitework shall: (a) meet the Technical Requirements (b) take account of the design (c) follow established good practice and workmanship**

Sitework that complies with the design and guidance below will be acceptable for building near trees.

## FOUNDATION DEPTHS

**4.2 - S2 Foundation depths shall be in accordance with the design**

A site plan should show the trees and hedgerows that affect the site together with the type, depth and dimensions of the

# 4.2 Building near trees

foundations that are within the influence of those trees and hedgerows. Where trees or hedgerows are either not shown or are in different positions and there is shrinkable soil, it may be necessary to adjust the foundation depths on site. Foundation depths should be determined in accordance with Design clause D6 or the electronic foundation depth calculator (Download to your PC) (Download to your Mac). If in doubt about any of the information either assume the worst conditions or consult a suitably qualified Engineer.

An Engineer should be consulted where foundation depths exceed 2.5m (see Technical Requirements R5).

**Figure 4 Electronic foundation depth calculator**

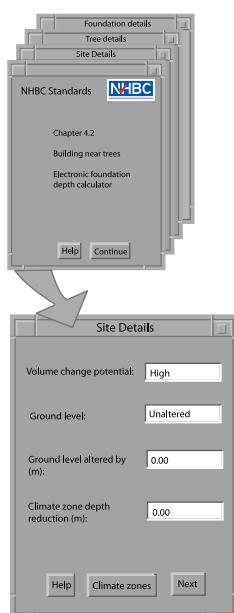

## EXCAVATION FOR FOUNDATIONS

### 4.2 - S3 Excavation for foundations shall take account of the design and be suitable to receive concrete

Items to be taken into account include:

#### (a) measurement of foundation depths

Foundation depths should be measured on the centre line of the excavation.

Where ground levels are to remain unaltered foundation depths should be measured from original ground level.

Where ground levels are reduced or increased (either in the recent past or during construction) foundation depths should be measured as shown in Figures 5 to 7.

**Figure 5 Levels from which foundation depths are measured where trees or hedgerows are to remain**

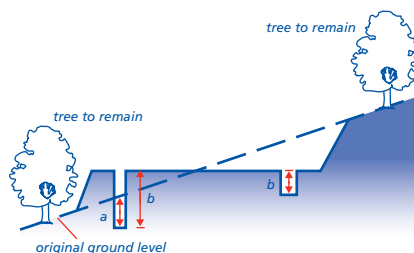

Use the lower of:  
 a: foundation depth based on appropriate tree height (see Figure 8)  
 b: foundation depth based on mature height of tree

**Figure 6 Levels from which foundation depths are measured where trees or hedgerows are removed**

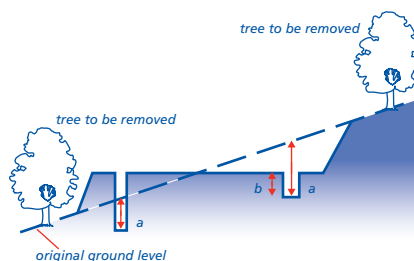

Use the lower of:  
 a: foundation depth based on appropriate tree height (see Figure 8)  
 b: minimum foundation depth (see Table 8)

**Figure 7 Levels from which foundation depths are measured where trees or hedgerows are proposed**

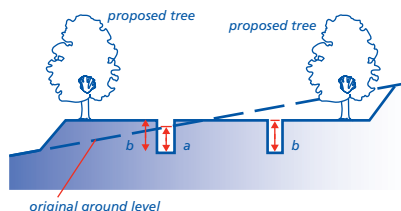

Use the lower of:  
 a: minimum foundation depth (see Table 8)  
 b: foundation depth based on mature height of tree

**Figure 8 Tree height H to be used for particular design cases**

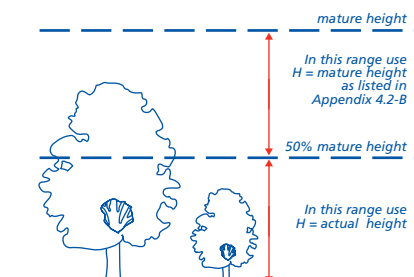

Figure 8 should be used when:  
 • deriving foundation depths when trees have been removed (use tree height at time of removal - see Design clause 4.2 - D5(a))  
 • checking the appropriate level from which depths should be measured when trees remain and ground levels are increased (use tree height at time of construction relative to original ground level - see Figure 5)  
 • determining whether heave precautions should be provided (use tree height at time of construction - see Sitework clause 4.2 - S4(a) and (b)).

**Table 8 Minimum foundation depths**

Volume change potential	Minimum depth [m]
High	1.0
Medium	0.9
Low	0.75

#### (b) stepped foundations

For stepped foundations, the relevant recommendations of Chapter 4.4 'Strip and trench fill foundations' should be followed with the additional precaution that the maximum step height should not exceed 0.5m as shown in Figure 9.

On sloping ground, foundation trenches can be gradually stepped so that the required foundation depth is reasonably uniform below ground level.

**Figure 9 Stepped foundations**

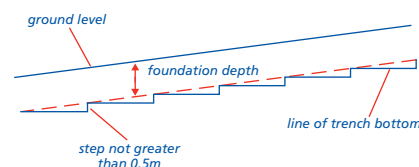

#### (c) trench bottoms

Where trench bottoms become excessively dried or softened due to rain or ground water, the excavation should be re-bottomed prior to concreting.

Some root activity may be expected below the depths determined in accordance with Design clause D6. However, if significant quantities of roots are unexpectedly encountered in the base of the trench, the excavation should be deepened or consult an Engineer.

## HEAVE PRECAUTIONS

### 4.2 - S4 Heave precautions shall be incorporated into foundations and substructure in accordance with the design

The following details show the minimum requirements for common foundation types. They apply to all foundations within the zone of influence of trees which are to remain or be removed.

Correct placement of heave materials is essential to ensure the foundations and substructure are adequately protected from heave forces.

#### (a) heave precautions for trench fill foundations

Heave precautions should be provided as shown in Figure 10.

Compressible material should be provided against the inside faces of all external wall foundations greater than 1.5m deep based on the appropriate tree height (see Figure 8).

No compressible material is required against the faces of internal foundations.



Heave precautions are not required for proposed trees as the soil has not been desiccated and therefore heave cannot take place.

**Figure 10 Heave precautions for trench fill foundations up to 2.5m deep**

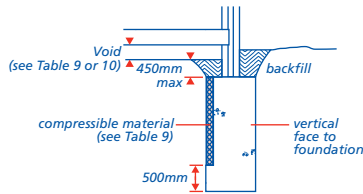

It is essential that:

- compressible material is provided to the entire area shown, and the foundation excavation has a vertical face.
- Where the excavation is battered or if there is over break or concrete overspill it may be necessary to consult an Engineer.

Trench fill foundations deeper than 2.5m will only be acceptable where they are designed by an Engineer (see Technical Requirement R5).

**(b) heave precautions for pier and beam foundations**

Heave precautions should be provided as shown in Figure 11.

Compressible material should be provided against all faces of the pier foundation which are greater than 1.5m deep based on the appropriate tree height (see Figure 8).

A void, void former or compressible material should be provided below all ground beams.

Compressible material or a void former should also be provided against the inside faces of external ground beams unless NHBC is satisfied that the soil, at this level, is not desiccated.

Heave precautions are not required for proposed trees as the soil has not been desiccated and heave cannot take place.

**Figure 11 Heave precautions for pier and beam foundations**

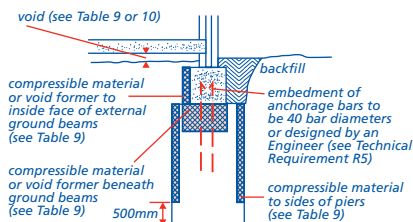

It is essential that heave material is provided to the entire areas shown. Particular care should be taken to ensure that the full width of the ground beam is protected.

**(c) heave precautions for pile and beam foundations**

Heave precautions should be provided as shown in Figure 12.

A void, void former or compressible material should be provided below all ground beams.

Compressible material or a void former should also be provided against the inside

faces of external ground beams unless NHBC is satisfied that the soil, at this level, is not desiccated.

Heave precautions are not required for proposed trees as the soil has not been desiccated and heave cannot take place.

**Figure 12 Heave precautions for pile and beam foundations**

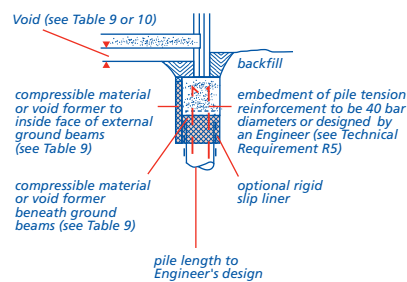

It is essential that heave material is provided to the entire areas shown. Particular care should be taken to ensure that the full width of the ground beam and the areas around the piles are protected.

**(d) minimum void dimensions**

Voids should be provided to accommodate movement in accordance with Tables 9 and 10.

**Table 9 Minimum void dimension for foundations, ground beams and suspended in-situ concrete ground floors**

Volume change potential	Against side of foundation and ground beam	
	Void dimension [mm] <sup>1</sup>	Void dimension [mm] <sup>1</sup>
High	35	150
Medium	25	100
Low	0	50

**Note:**

- 1 For compressible material the void dimension is the amount the material should be able to compress to accommodate heave. The actual thickness of compressible material required should be established from the manufacturer's recommendations and is generally in the order of twice the void dimension shown. For void formers the void dimension is the remaining void after collapse. The actual thickness of void former required should be established from the manufacturer's recommendations.

**Table 10 Minimum void dimensions under suspended floors**

Volume change potential	Precast concrete and suspended timber floors	
	Void dimension [mm]	
High	300	
Medium	250	
Low	200	

**Note:**

- 1 The void dimension measurement is from the underside of beam or joist to ground level and includes 150mm ventilation allowance.

## DRAINAGE

**4.2 - S5 Drainage shall be in accordance with the design and allow for ground movement**

Drainage construction should be in accordance with the design and the relevant recommendations of Chapter 5.3 'Drainage below ground' should be followed.

Additional items to take into account include:

- falls should be sufficient to cater for possible ground movement or alternative means should be used to reduce the extent of potential movement, for example by taking the excavation deeper and laying the pipework on granular bedding of suitable thickness
- a drainage system capable of accommodating the likely movement should be used
- pipes passing through substructure walls or trench fill foundations should have sufficient clearance to take account of the potential ground movement indicated in Table 11.

**Table 11 Minimum allowance for potential ground movement**

Volume change potential	Potential ground movement [mm]
High	150
Medium	100
Low	50

Existing land drains should be maintained or diverted. Where the void beneath suspended floors is liable to flooding, drainage should be provided.

4.2

# 4.2 Building near trees

## APPENDIX 4.2-A

### Water demand and mature height of trees

Table 12

Broad leaved trees		
Water demand	Species	Mature height [m]
High	Elm	
	English	24
	Wheatley	22
	Wych	18
	Eucalyptus	18
	Hawthorn	10
	Oak	
	English	20
	Holm	16
	Red	24
	Turkey	24
	Poplar	
	Hybrid black	28
	Lombardy	25
	White	15
	Willow	
	Crack	24
Weeping	16	
White	24	
Moderate	Acacia false	18
	Alder	18
	Apple	10
	Ash	23
	Bay Laurel	10
	Beech	20
	Blackthorn	8
	Cherry	
	Japanese	9
	Laurel	8
	Orchard	12
	Wild	17
	Chestnut	
	Horse	20
	Sweet	24
	Lime	22
	Maple	
	Japanese	8
	Norway	18
	Mountain Ash	11
	Pear	12
	Plane	26
	Plum	10
	Sycamore	22
	Tree of Heaven	20
	Walnut	18
	Whitebeam	12
Low	Birch	14
	Elder	10
	Fig	8
	Hazel	8
	Holly	12
	Honey Locust	14
	Hornbeam	17
	Laburnum	12
	Magnolia	9
	Mulberry	9
	Tulip tree	20

Coniferous trees		
Water demand	Species	Mature height [m]
High	Cypress	
	Lawson's	18
	Leyland	20
Monterey	20	
Moderate	Cedar	20
	Douglas fir	20
	Larch	20
	Monkey Puzzle	18
	Pine	20
	Spruce	18
	Wellingtonia	30
	Yew	12

Note:

- 1 Where hedgerows contain trees, their effect should be assessed separately. In hedgerows, the height of the species likely to have the greatest effect should be used.
- 2 Within the classes of water demand, species are listed alphabetically; the order does not signify any gradation in water demand.
- 3 When the species is known but the sub-species is not, the greatest height listed for the species should be assumed.
- 4 Further information regarding trees may be obtained from the Arboricultural Association or the Arboricultural Advisory and Information service (see Appendix 4.2-E)

APPENDIX 4.2-B

Foundation Depth Charts

Table 13 Determination of D/H Value

Distance D (m)	Tree height H (m)														
	2	4	6	8	10	12	14	16	18	20	22	24	26	28	30
1	0.50	0.25	0.17	0.13	0.10	0.08	0.07	0.06	0.06	0.05	0.05	0.04	0.04	0.04	0.03
2	1.00	0.50	0.33	0.25	0.20	0.17	0.14	0.13	0.11	0.10	0.09	0.08	0.08	0.07	0.07
3		0.75	0.50	0.38	0.30	0.25	0.21	0.19	0.17	0.15	0.14	0.13	0.12	0.11	0.10
4		1.00	0.67	0.50	0.40	0.33	0.29	0.25	0.22	0.20	0.18	0.17	0.15	0.14	0.13
5			0.83	0.63	0.50	0.42	0.36	0.31	0.28	0.25	0.23	0.21	0.19	0.18	0.17
6			1.00	0.75	0.60	0.50	0.43	0.38	0.33	0.30	0.27	0.25	0.23	0.21	0.20
7			1.17	0.88	0.70	0.58	0.50	0.44	0.39	0.35	0.32	0.29	0.27	0.25	0.23
8				1.00	0.80	0.67	0.57	0.50	0.44	0.40	0.36	0.33	0.31	0.29	0.27
9				1.13	0.90	0.75	0.64	0.56	0.50	0.45	0.41	0.38	0.35	0.32	0.30
10					1.00	0.83	0.71	0.63	0.56	0.50	0.45	0.42	0.38	0.36	0.33
11					1.10	0.92	0.79	0.69	0.61	0.55	0.50	0.46	0.42	0.39	0.37
12					1.20	1.00	0.86	0.75	0.67	0.60	0.55	0.50	0.46	0.43	0.40
13						1.08	0.93	0.81	0.72	0.65	0.59	0.54	0.50	0.46	0.43
14						1.17	1.00	0.88	0.78	0.70	0.64	0.58	0.54	0.50	0.47
15							1.07	0.94	0.83	0.75	0.68	0.63	0.58	0.54	0.50
16							1.14	1.00	0.89	0.80	0.73	0.67	0.62	0.57	0.53
17							1.21	1.06	0.94	0.85	0.77	0.71	0.65	0.61	0.57
18								1.13	1.00	0.90	0.82	0.75	0.69	0.64	0.60
19								1.19	1.06	0.95	0.86	0.79	0.73	0.68	0.63
20									1.11	1.00	0.91	0.83	0.77	0.71	0.67
21									1.17	1.05	0.95	0.88	0.81	0.75	0.70
22										1.10	1.00	0.92	0.85	0.79	0.73
23										1.15	1.05	0.96	0.88	0.82	0.77
24										1.20	1.09	1.00	0.92	0.86	0.80
25											1.14	1.04	0.96	0.89	0.83
26											1.18	1.08	1.00	0.93	0.87
27												1.13	1.04	0.96	0.90
28												1.17	1.08	1.00	0.93
29												1.21	1.12	1.04	0.97
30													1.15	1.07	1.00
31													1.19	1.11	1.03
32														1.14	1.07
33														1.18	1.10
34														1.21	1.13
35															1.17
36															1.20

Where no value is given in the table, minimum foundation depths apply (i.e. 1.0m, 0.9m and 0.75m for high, medium and low volume change potential soils respectively).

# 4.2 Building near trees

**Chart 1 Soils with HIGH volume change potential: Modified Plasticity Index 40% or greater**  
 (see Design clause D5(b))

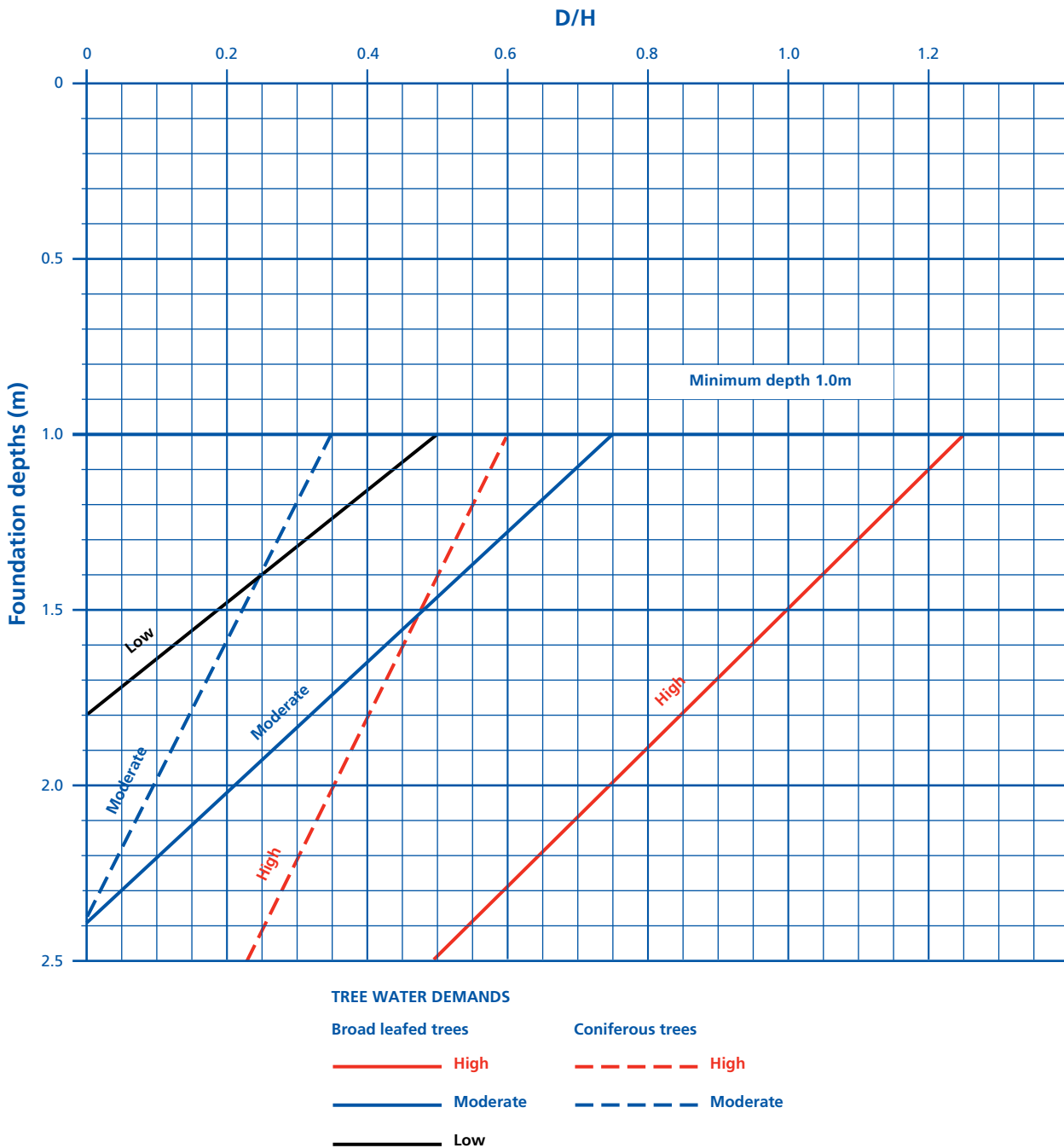

4.2

**Chart 2 Soils with MEDIUM volume change potential: Modified Plasticity Index between 20% and less than 40%**  
 (see Design clause D5(b))

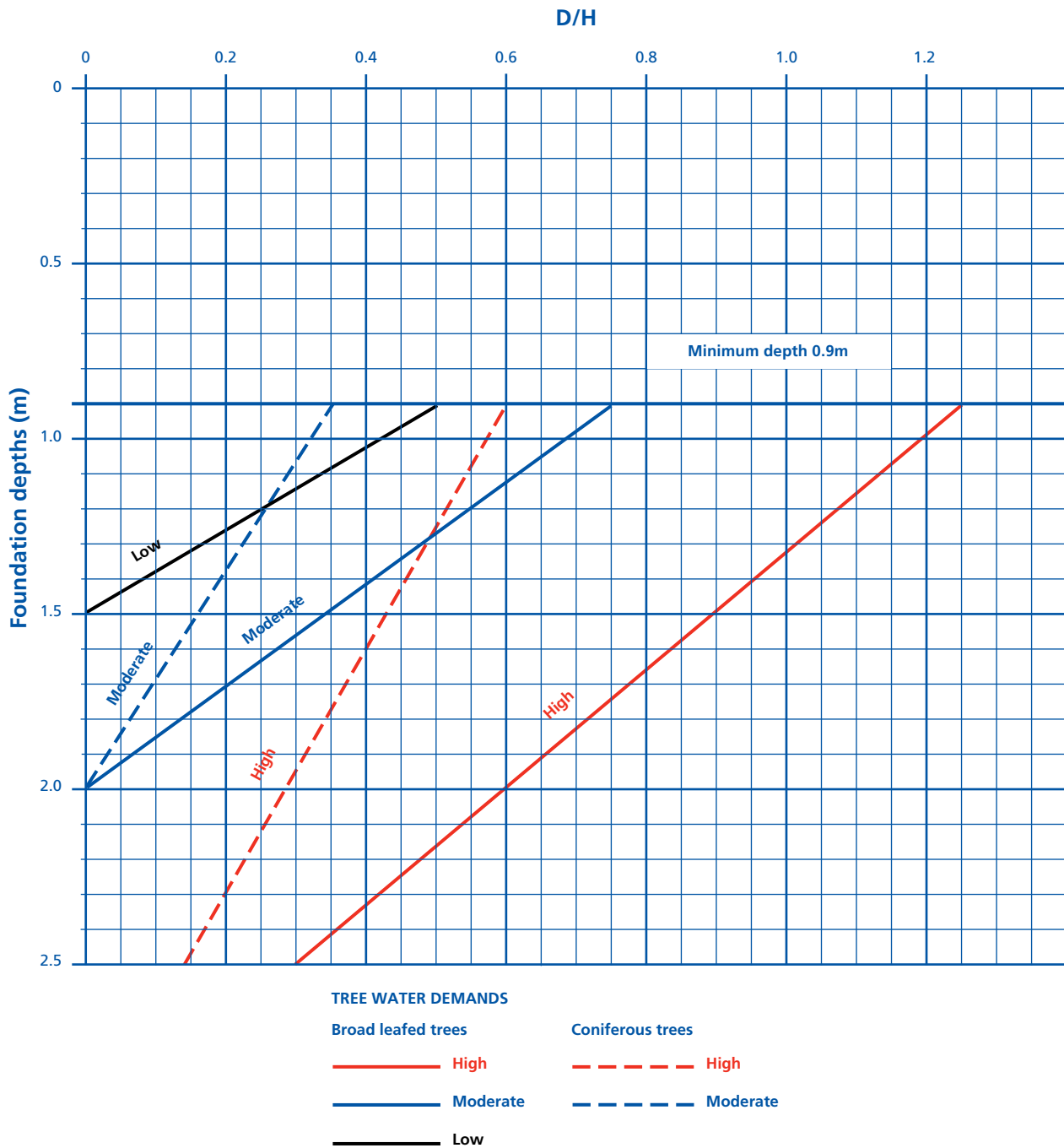

4.2

# 4.2 Building near trees

**Chart 3 Soils with LOW volume change potential: Modified Plasticity Index 10 to less than 20%**  
 (see Design clause D5(b))

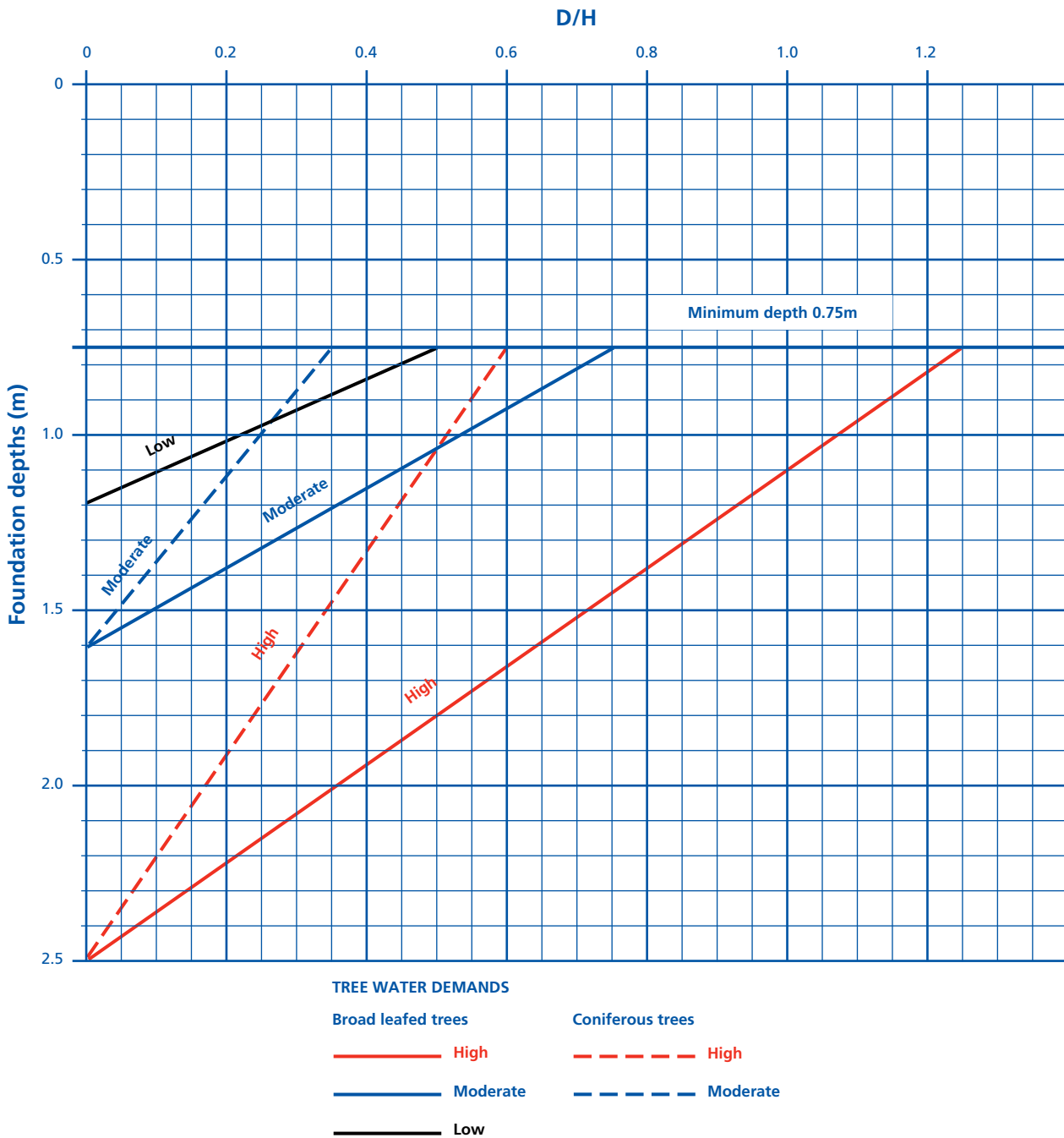

4.2

APPENDIX 4.2-C

Foundation depth tables

Table 14 - HIGH shrinkage soil and HIGH water demand tree

Broad leaved trees

Foundation depth (m)		Tree height H (m)											
Distance D (m)	Tree height H (m)												
	8	10	12	14	16	18	20	22	24	26	28	30	
1	Foundations greater than 2.5m deep to be Engineer designed												
2													
3													
4	2.50												
5	2.25	2.50											
6	2.00	2.30	2.50										
7	1.75	2.10	2.35	2.50									
8	1.50	1.90	2.20	2.40	2.50								
9	1.25	1.70	2.00	2.25	2.40	2.50							
10	1.00	1.50	1.85	2.10	2.25	2.40	2.50						
11	1.00	1.30	1.70	1.95	2.15	2.30	2.40	2.50					
12	1.00	1.10	1.50	1.80	2.00	2.20	2.30	2.45	2.50				
13	1.00	1.35	1.65	1.90	2.10	2.20	2.35	2.45	2.50				
14	1.00	1.20	1.50	1.75	1.95	2.10	2.25	2.35	2.45	2.50			
15	1.00	1.40	1.65	1.85	2.00	2.15	2.25	2.35	2.45	2.50			
16	1.00	1.25	1.50	1.75	1.90	2.05	2.20	2.30	2.40	2.45			
17	1.00	1.10	1.40	1.65	1.80	1.95	2.10	2.20	2.30	2.40			
18	1.00	1.25	1.50	1.70	1.90	2.00	2.15	2.25	2.30				
19	1.00	1.15	1.40	1.60	1.80	1.95	2.05	2.15	2.25				
20	1.00	1.30	1.50	1.70	1.85	2.00	2.10	2.20					
21	1.00	1.20	1.40	1.60	1.75	1.90	2.00	2.10					
22	1.00	1.10	1.30	1.50	1.70	1.85	1.95	2.05					
23	1.00	1.20	1.45	1.60	1.75	1.90	2.00						
24	1.00	1.10	1.35	1.50	1.65	1.80	1.90						
25	1.00	1.25	1.45	1.60	1.75	1.85							
26	1.00	1.15	1.35	1.50	1.65	1.80							
27	1.00	1.05	1.25	1.45	1.60	1.70							
28	1.00	1.20	1.35	1.50	1.65								
29	1.00	1.10	1.30	1.45	1.60								
30	1.00	1.20	1.40	1.50									
31	1.00	1.15	1.30	1.45									
32	1.00	1.05	1.25	1.40									
33	1.00	1.15	1.30										
34	1.00	1.10	1.25										
35	1.00	1.20											
36	1.00	1.10											
37	1.00	1.05											
38	1.00												

Coniferous trees

Foundation depth (m)		Tree height H (m)											
Distance D (m)	Tree height H (m)												
	8	10	12	14	16	18	20	22	24	26	28	30	
1	Foundations greater than 2.5m deep to be Engineer designed												
2													
3													
4	1.95	2.25	2.50	2.35	2.50								
5	1.00	1.45	1.80	2.05	2.20	2.35	2.50						
6	1.00	1.45	1.75	1.95	2.15	2.25	2.40	2.50					
7	1.00	1.10	1.45	1.70	1.90	2.05	2.20	2.30	2.40	2.50			
8	1.00	1.15	1.45	1.65	1.85	2.00	2.15	2.25	2.35	2.40			
9	1.00	1.20	1.45	1.65	1.80	1.95	2.10	2.20	2.25				
10	1.00	1.20	1.45	1.65	1.80	1.90	2.05	2.15					
11	1.00	1.25	1.45	1.60	1.75	1.90	2.00						
12	1.00	1.25	1.45	1.60	1.75	1.85							
13	1.00	1.05	1.25	1.45	1.60	1.70							
14	1.00	1.10	1.30	1.45	1.60								
15	1.00	1.10	1.30	1.45									
16	1.00	1.15	1.30										
17	1.00	1.15											
18	1.00												
19	1.0m minimum foundation depth												
20	1.0m minimum foundation depth												
21	1.0m minimum foundation depth												
22	1.0m minimum foundation depth												
23	1.0m minimum foundation depth												
24	1.0m minimum foundation depth												
25	1.0m minimum foundation depth												
26	1.0m minimum foundation depth												
27	1.0m minimum foundation depth												
28	1.0m minimum foundation depth												
29	1.0m minimum foundation depth												
30	1.0m minimum foundation depth												
31	1.0m minimum foundation depth												
32	1.0m minimum foundation depth												
33	1.0m minimum foundation depth												
34	1.0m minimum foundation depth												
35	1.0m minimum foundation depth												
36	1.0m minimum foundation depth												
37	1.0m minimum foundation depth												
38	1.0m minimum foundation depth												

4.2

# 4.2 Building near trees

**Table 15 - HIGH Shrinkage soil and MODERATE water demand tree**

Broad leaved trees

Foundation depth (m)												
Distance D (m)	Tree height H (m)											
	8	10	12	14	16	18	20	22	24	26	28	30
1	2.20	2.25	2.25	2.30	2.30	2.30	2.35	2.35	2.35	2.35	2.35	2.35
2	1.95	2.05	2.10	2.15	2.20	2.20	2.25	2.25	2.25	2.30	2.30	2.30
3	1.70	1.85	1.95	2.00	2.05	2.10	2.15	2.15	2.20	2.20	2.20	2.25
4	1.50	1.65	1.80	1.90	1.95	2.00	2.05	2.10	2.10	2.15	2.15	2.15
5	1.25	1.50	1.65	1.75	1.85	1.90	1.95	2.00	2.05	2.05	2.10	2.10
6	1.00	1.30	1.50	1.60	1.70	1.80	1.85	1.90	1.95	2.00	2.00	2.05
7	1.00	1.10	1.35	1.50	1.60	1.70	1.75	1.85	1.90	1.90	1.95	2.00
8	1.00	1.00	1.20	1.35	1.50	1.60	1.65	1.75	1.80	1.85	1.90	1.90
9	1.00	1.00	1.00	1.20	1.35	1.50	1.60	1.65	1.70	1.75	1.80	1.85
10	1.00	1.00	1.00	1.10	1.25	1.40	1.50	1.55	1.65	1.70	1.75	1.80
11	1.00	1.00	1.00	1.00	1.15	1.30	1.40	1.50	1.55	1.65	1.70	1.75
12	1.00	1.00	1.00	1.00	1.00	1.20	1.30	1.40	1.50	1.55	1.60	1.65
13	1.00	1.00	1.00	1.00	1.00	1.05	1.20	1.30	1.40	1.50	1.55	1.60
14	1.00	1.00	1.00	1.00	1.00	1.00	1.10	1.25	1.35	1.40	1.50	1.55
15	1.00	1.00	1.00	1.00	1.00	1.00	1.05	1.15	1.25	1.35	1.40	1.50
16	1.00	1.00	1.00	1.00	1.00	1.00	1.00	1.05	1.20	1.25	1.35	1.40
17	1.00	1.00	1.00	1.00	1.00	1.00	1.00	1.00	1.10	1.20	1.30	1.35
18	1.00	1.00	1.00	1.00	1.00	1.00	1.00	1.00	1.00	1.15	1.20	1.30
19	1.00	1.00	1.00	1.00	1.00	1.00	1.00	1.00	1.00	1.05	1.15	1.25
20	1.00	1.00	1.00	1.00	1.00	1.00	1.00	1.00	1.00	1.00	1.10	1.20
21	1.00	1.00	1.00	1.00	1.00	1.00	1.00	1.00	1.00	1.00	1.00	1.10
22	1.00	1.00	1.00	1.00	1.00	1.00	1.00	1.00	1.00	1.00	1.00	1.05
23	1.00	1.00	1.00	1.00	1.00	1.00	1.00	1.00	1.00	1.00	1.00	1.00

Coniferous trees

Foundation depth (m)												
Distance D (m)	Tree height H (m)											
	8	10	12	14	16	18	20	22	24	26	28	30
1	1.90	2.00	2.10	2.15	2.15	2.20	2.20	2.25	2.25	2.25	2.30	2.30
2	1.40	1.60	1.75	1.85	1.90	2.00	2.00	2.05	2.10	2.10	2.15	2.15
3	1.00	1.20	1.40	1.55	1.65	1.75	1.80	1.85	1.90	1.95	2.00	2.00
4	1.00	1.00	1.10	1.30	1.40	1.55	1.60	1.70	1.75	1.80	1.85	1.90
5	1.00	1.00	1.00	1.00	1.15	1.30	1.40	1.50	1.60	1.65	1.70	1.75
6	1.00	1.00	1.00	1.00	1.00	1.10	1.20	1.35	1.40	1.50	1.55	1.60
7	1.00	1.00	1.00	1.00	1.00	1.00	1.00	1.15	1.25	1.35	1.40	1.50
8	1.00	1.00	1.00	1.00	1.00	1.00	1.00	1.00	1.10	1.20	1.30	1.35
9	1.00	1.00	1.00	1.00	1.00	1.00	1.00	1.00	1.00	1.05	1.15	1.20
10	1.00	1.00	1.00	1.00	1.00	1.00	1.00	1.00	1.00	1.00	1.00	1.10
11	1.00	1.00	1.00	1.00	1.00	1.00	1.00	1.00	1.00	1.00	1.00	1.00
12	1.00	1.00	1.00	1.00	1.00	1.00	1.00	1.00	1.00	1.00	1.00	1.00
13	1.00	1.00	1.00	1.00	1.00	1.00	1.00	1.00	1.00	1.00	1.00	1.00
14	1.00	1.00	1.00	1.00	1.00	1.00	1.00	1.00	1.00	1.00	1.00	1.00
15	1.00	1.00	1.00	1.00	1.00	1.00	1.00	1.00	1.00	1.00	1.00	1.00
16	1.00	1.00	1.00	1.00	1.00	1.00	1.00	1.00	1.00	1.00	1.00	1.00
17	1.00	1.00	1.00	1.00	1.00	1.00	1.00	1.00	1.00	1.00	1.00	1.00
18	1.00	1.00	1.00	1.00	1.00	1.00	1.00	1.00	1.00	1.00	1.00	1.00
19	1.00	1.00	1.00	1.00	1.00	1.00	1.00	1.00	1.00	1.00	1.00	1.00
20	1.00	1.00	1.00	1.00	1.00	1.00	1.00	1.00	1.00	1.00	1.00	1.00
21	1.00	1.00	1.00	1.00	1.00	1.00	1.00	1.00	1.00	1.00	1.00	1.00
22	1.00	1.00	1.00	1.00	1.00	1.00	1.00	1.00	1.00	1.00	1.00	1.00
23	1.00	1.00	1.00	1.00	1.00	1.00	1.00	1.00	1.00	1.00	1.00	1.00

**Table 16 - HIGH shrinkage soil and LOW water demand tree**

Broad leaved trees

Foundation depth (m)												
Distance D (m)	Tree height H (m)											
	8	10	12	14	16	18	20	22	24	26	28	30
1	1.60	1.65	1.70	1.70	1.70	1.75	1.75	1.75	1.75	1.75	1.75	1.75
2	1.40	1.50	1.55	1.60	1.60	1.65	1.65	1.65	1.65	1.70	1.70	1.70
3	1.20	1.35	1.40	1.50	1.50	1.55	1.60	1.60	1.60	1.65	1.65	1.65
4	1.00	1.20	1.30	1.35	1.40	1.45	1.50	1.55	1.55	1.55	1.60	1.60
5	1.00	1.00	1.15	1.25	1.30	1.40	1.40	1.45	1.50	1.50	1.55	1.55
6	1.00	1.00	1.00	1.15	1.20	1.30	1.35	1.40	1.40	1.45	1.50	1.50
7	1.00	1.00	1.00	1.00	1.10	1.20	1.25	1.30	1.35	1.40	1.40	1.45
8	1.00	1.00	1.00	1.00	1.00	1.10	1.20	1.25	1.30	1.35	1.35	1.40
9	1.00	1.00	1.00	1.00	1.00	1.00	1.10	1.15	1.20	1.25	1.30	1.35
10	1.00	1.00	1.00	1.00	1.00	1.00	1.00	1.10	1.15	1.20	1.25	1.30
11	1.00	1.00	1.00	1.00	1.00	1.00	1.00	1.00	1.10	1.15	1.20	1.25
12	1.00	1.00	1.00	1.00	1.00	1.00	1.00	1.00	1.00	1.10	1.15	1.20
13	1.00	1.00	1.00	1.00	1.00	1.00	1.00	1.00	1.00	1.00	1.10	1.15
14	1.00	1.00	1.00	1.00	1.00	1.00	1.00	1.00	1.00	1.00	1.00	1.05
15	1.00	1.00	1.00	1.00	1.00	1.00	1.00	1.00	1.00	1.00	1.00	1.00

4.2



**Table 17 - MEDIUM shrinkage soil and HIGH water demand tree**

Broad leaved trees

Foundation depth (m)												
Distance D (m)	Tree Height H (m)											
	8	10	12	14	16	18	20	22	24	26	28	30
1	Foundations greater than 2.5m deep to be Engineer designed											
2												
3	2.40	2.50										
4	2.20	2.35	2.45									
5	1.95	2.20	2.30	2.40	2.50							
6	1.75	2.00	2.20	2.30	2.40	2.45	2.50					
7	1.55	1.85	2.05	2.20	2.30	2.35	2.45	2.50				
8	1.35	1.70	1.90	2.05	2.20	2.25	2.35	2.40	2.45	2.50		
9	1.15	1.50	1.75	1.95	2.10	2.20	2.25	2.35	2.40	2.45	2.50	2.50
10	0.90	1.35	1.60	1.80	1.95	2.10	2.20	2.25	2.30	2.35	2.40	2.45
11	0.90	1.15	1.50	1.70	1.85	2.00	2.10	2.20	2.25	2.30	2.35	2.40
12	0.90	1.00	1.35	1.60	1.75	1.90	2.00	2.10	2.20	2.25	2.30	2.35
13	0.90	0.90	1.20	1.45	1.65	1.80	1.95	2.05	2.10	2.20	2.25	2.30
14	0.90	0.90	1.05	1.35	1.55	1.70	1.85	1.95	2.05	2.10	2.20	2.25
15	0.90	0.90	0.90	1.20	1.45	1.60	1.75	1.85	1.95	2.05	2.10	2.20
16	0.90	0.90	0.90	1.10	1.35	1.55	1.70	1.80	1.90	2.00	2.05	2.10
17	0.90	0.90	0.90	1.00	1.25	1.45	1.60	1.70	1.85	1.90	2.00	2.05
18	0.90	0.90	0.90	0.90	1.15	1.35	1.50	1.65	1.75	1.85	1.95	2.00
19	0.90	0.90	0.90	0.90	1.05	1.25	1.40	1.55	1.70	1.80	1.90	1.95
20	0.90	0.90	0.90	0.90	0.90	1.15	1.35	1.50	1.60	1.75	1.80	1.90
21	0.90	0.90	0.90	0.90	0.90	1.05	1.25	1.40	1.55	1.65	1.75	1.85
22	0.90	0.90	0.90	0.90	0.90	0.95	1.15	1.35	1.50	1.60	1.70	1.80
23	0.90	0.90	0.90	0.90	0.90	0.90	1.10	1.25	1.40	1.55	1.65	1.75
24	0.90	0.90	0.90	0.90	0.90	0.90	1.00	1.20	1.35	1.45	1.60	1.70
25	0.90	0.90	0.90	0.90	0.90	0.90	0.90	1.10	1.25	1.40	1.50	1.60
26	0.90	0.90	0.90	0.90	0.90	0.90	0.90	1.05	1.20	1.35	1.45	1.55
27	0.90	0.90	0.90	0.90	0.90	0.90	0.90	0.95	1.15	1.30	1.40	1.50
28	0.90	0.90	0.90	0.90	0.90	0.90	0.90	0.90	1.05	1.20	1.35	1.45
29	0.90	0.90	0.90	0.90	0.90	0.90	0.90	0.90	1.00	1.15	1.30	1.40
30	0.90	0.90	0.90	0.90	0.90	0.90	0.90	0.90	0.90	1.10	1.20	1.35
31	0.90	0.90	0.90	0.90	0.90	0.90	0.90	0.90	0.90	1.00	1.15	1.30
32	0.90	0.90	0.90	0.90	0.90	0.90	0.90	0.90	0.90	0.95	1.10	1.25
33	0.90	0.90	0.90	0.90	0.90	0.90	0.90	0.90	0.90	0.90	1.05	1.15
34	0.90	0.90	0.90	0.90	0.90	0.90	0.90	0.90	0.90	0.90	1.00	1.10
35	0.90	0.90	0.90	0.90	0.90	0.90	0.90	0.90	0.90	0.90	0.90	1.05
36	0.90	0.90	0.90	0.90	0.90	0.90	0.90	0.90	0.90	0.90	0.90	1.00
37	0.90	0.90	0.90	0.90	0.90	0.90	0.90	0.90	0.90	0.90	0.90	0.95
38	0.90	0.90	0.90	0.90	0.90	0.90	0.90	0.90	0.90	0.90	0.90	0.90

**Table 17**

Coniferous trees

Foundation depth (m)												
Distance D (m)	Tree Height H (m)											
	8	10	12	14	16	18	20	22	24	26	28	30
1	Foundations greater than 2.5m deep to be Engineer designed											
2												
3	2.15	2.30	2.45	2.50								
4	1.70	1.95	2.15	2.25	2.35	2.45	2.50					
5	1.25	1.60	1.85	2.00	2.15	2.25	2.30	2.40	2.45	2.50	2.50	2.50
6	0.90	1.25	1.55	1.75	1.95	2.05	2.15	2.20	2.30	2.35	2.40	2.45
7	0.90	0.90	1.25	1.50	1.70	1.85	1.95	2.05	2.15	2.20	2.25	2.30
8	0.90	0.90	1.00	1.25	1.50	1.65	1.80	1.90	2.00	2.10	2.15	2.20
9	0.90	0.90	0.90	1.00	1.25	1.45	1.60	1.75	1.85	1.95	2.00	2.10
10	0.90	0.90	0.90	0.90	1.05	1.25	1.45	1.60	1.70	1.80	1.90	1.95
11	0.90	0.90	0.90	0.90	0.90	1.10	1.25	1.45	1.55	1.65	1.75	1.85
12	0.90	0.90	0.90	0.90	0.90	0.90	1.10	1.25	1.40	1.55	1.65	1.75
13	0.90	0.90	0.90	0.90	0.90	0.90	0.90	1.10	1.25	1.40	1.50	1.60
14	0.90	0.90	0.90	0.90	0.90	0.90	0.90	0.90	1.10	1.25	1.40	1.50
15	0.90	0.90	0.90	0.90	0.90	0.90	0.90	0.90	0.90	1.10	1.25	1.40
16	0.90	0.90	0.90	0.90	0.90	0.90	0.90	0.90	0.90	0.90	1.10	1.15
17	0.90	0.90	0.90	0.90	0.90	0.90	0.90	0.90	0.90	0.90	0.90	1.05
18	0.90	0.90	0.90	0.90	0.90	0.90	0.90	0.90	0.90	0.90	0.90	0.90
19	0.90	0.90	0.90	0.90	0.90	0.90	0.90	0.90	0.90	0.90	0.90	0.90
20	0.90	0.90	0.90	0.90	0.90	0.90	0.90	0.90	0.90	0.90	0.90	0.90
21	0.90	0.90	0.90	0.90	0.90	0.90	0.90	0.90	0.90	0.90	0.90	0.90
22	0.90	0.90	0.90	0.90	0.90	0.90	0.90	0.90	0.90	0.90	0.90	0.90
23	0.90	0.90	0.90	0.90	0.90	0.90	0.90	0.90	0.90	0.90	0.90	0.90
24	0.90	0.90	0.90	0.90	0.90	0.90	0.90	0.90	0.90	0.90	0.90	0.90
25	0.90	0.90	0.90	0.90	0.90	0.90	0.90	0.90	0.90	0.90	0.90	0.90
26	0.90	0.90	0.90	0.90	0.90	0.90	0.90	0.90	0.90	0.90	0.90	0.90
27	0.90	0.90	0.90	0.90	0.90	0.90	0.90	0.90	0.90	0.90	0.90	0.90
28	0.90	0.90	0.90	0.90	0.90	0.90	0.90	0.90	0.90	0.90	0.90	0.90
29	0.90	0.90	0.90	0.90	0.90	0.90	0.90	0.90	0.90	0.90	0.90	0.90
30	0.90	0.90	0.90	0.90	0.90	0.90	0.90	0.90	0.90	0.90	0.90	0.90
31	0.90	0.90	0.90	0.90	0.90	0.90	0.90	0.90	0.90	0.90	0.90	0.90
32	0.90	0.90	0.90	0.90	0.90	0.90	0.90	0.90	0.90	0.90	0.90	0.90
33	0.90	0.90	0.90	0.90	0.90	0.90	0.90	0.90	0.90	0.90	0.90	0.90
34	0.90	0.90	0.90	0.90	0.90	0.90	0.90	0.90	0.90	0.90	0.90	0.90
35	0.90	0.90	0.90	0.90	0.90	0.90	0.90	0.90	0.90	0.90	0.90	0.90
36	0.90	0.90	0.90	0.90	0.90	0.90	0.90	0.90	0.90	0.90	0.90	0.90
37	0.90	0.90	0.90	0.90	0.90	0.90	0.90	0.90	0.90	0.90	0.90	0.90
38	0.90	0.90	0.90	0.90	0.90	0.90	0.90	0.90	0.90	0.90	0.90	0.90

4.2

# 4.2 Building near trees

**Table 18 - MEDIUM shrinkage soil and MODERATE water demand tree**

Broad leaved trees

Foundation depth (m)												
Distance D (m)	Tree height H (m)											
	8	10	12	14	16	18	20	22	24	26	28	30
1	1.85	1.85	1.90	1.90	1.95	1.95	1.95	1.95	1.95	1.95	1.95	1.95
2	1.65	1.75	1.80	1.80	1.85	1.85	1.85	1.90	1.90	1.90	1.90	1.90
3	1.45	1.60	1.65	1.70	1.75	1.80	1.80	1.80	1.85	1.85	1.85	1.85
4	1.30	1.45	1.55	1.60	1.65	1.70	1.75	1.75	1.80	1.80	1.80	1.80
5	1.10	1.30	1.40	1.50	1.55	1.60	1.65	1.70	1.70	1.75	1.75	1.80
6	0.90	1.15	1.30	1.40	1.45	1.55	1.60	1.60	1.65	1.70	1.70	1.75
7	0.90	1.00	1.15	1.30	1.40	1.45	1.50	1.55	1.60	1.65	1.65	1.70
8	0.90	0.90	1.05	1.20	1.30	1.35	1.45	1.50	1.55	1.55	1.60	1.65
9	0.90	0.90	0.90	1.10	1.20	1.30	1.35	1.40	1.45	1.50	1.55	1.60
10	0.90	0.90	0.90	0.95	1.10	1.20	1.30	1.35	1.40	1.45	1.50	1.55
11	0.90	0.90	0.90	0.90	1.00	1.10	1.20	1.30	1.35	1.40	1.45	1.50
12	0.90	0.90	0.90	0.90	0.90	1.05	1.15	1.20	1.30	1.35	1.40	1.45
13	0.90	0.90	0.90	0.90	0.90	0.95	1.05	1.15	1.25	1.30	1.35	1.40
14	0.90	0.90	0.90	0.90	0.90	0.90	1.00	1.10	1.15	1.25	1.30	1.35
15	0.90	0.90	0.90	0.90	0.90	0.90	0.90	1.00	1.10	1.15	1.25	1.30
16	0.90	0.90	0.90	0.90	0.90	0.90	0.90	0.95	1.05	1.10	1.20	1.25
17	0.90	0.90	0.90	0.90	0.90	0.90	0.90	0.90	1.00	1.10	1.15	1.20
18	0.90	0.90	0.90	0.90	0.90	0.90	0.90	0.90	0.90	1.00	1.10	1.15
19	0.90	0.90	0.90	0.90	0.90	0.90	0.90	0.90	0.90	0.95	1.00	1.10
20	0.90	0.90	0.90	0.90	0.90	0.90	0.90	0.90	0.90	0.90	0.95	1.05
21	0.90	0.90	0.90	0.90	0.90	0.90	0.90	0.90	0.90	0.90	0.90	1.00
22	0.90	0.90	0.90	0.90	0.90	0.90	0.90	0.90	0.90	0.90	0.90	0.95
23	0.90	0.90	0.90	0.90	0.90	0.90	0.90	0.90	0.90	0.90	0.90	0.90

Coniferous trees

Foundation depth (m)												
Distance D (m)	Tree height H (m)											
	8	10	12	14	16	18	20	22	24	26	28	30
1	1.65	1.70	1.75	1.80	1.80	1.85	1.85	1.90	1.90	1.90	1.90	1.90
2	1.25	1.40	1.50	1.55	1.65	1.65	1.70	1.75	1.75	1.80	1.80	1.80
3	0.90	1.10	1.25	1.35	1.45	1.50	1.55	1.60	1.65	1.65	1.70	1.70
4	0.90	0.90	0.95	1.10	1.25	1.30	1.40	1.45	1.50	1.55	1.55	1.60
5	0.90	0.90	0.90	0.90	1.05	1.15	1.25	1.30	1.35	1.40	1.45	1.50
6	0.90	0.90	0.90	0.90	0.90	0.95	1.10	1.15	1.25	1.30	1.35	1.40
7	0.90	0.90	0.90	0.90	0.90	0.90	1.00	1.10	1.15	1.25	1.30	1.30
8	0.90	0.90	0.90	0.90	0.90	0.90	0.90	0.95	1.05	1.10	1.10	1.20
9	0.90	0.90	0.90	0.90	0.90	0.90	0.90	0.90	0.95	1.00	1.10	1.10
10	0.90	0.90	0.90	0.90	0.90	0.90	0.90	0.90	0.90	0.90	0.90	0.95
11	0.90	0.90	0.90	0.90	0.90	0.90	0.90	0.90	0.90	0.90	0.90	0.90
12	0.90	0.90	0.90	0.90	0.90	0.90	0.90	0.90	0.90	0.90	0.90	0.90
13	0.90	0.90	0.90	0.90	0.90	0.90	0.90	0.90	0.90	0.90	0.90	0.90
14	0.90	0.90	0.90	0.90	0.90	0.90	0.90	0.90	0.90	0.90	0.90	0.90
15	0.90	0.90	0.90	0.90	0.90	0.90	0.90	0.90	0.90	0.90	0.90	0.90
16	0.90	0.90	0.90	0.90	0.90	0.90	0.90	0.90	0.90	0.90	0.90	0.90
17	0.90	0.90	0.90	0.90	0.90	0.90	0.90	0.90	0.90	0.90	0.90	0.90
18	0.90	0.90	0.90	0.90	0.90	0.90	0.90	0.90	0.90	0.90	0.90	0.90
19	0.90	0.90	0.90	0.90	0.90	0.90	0.90	0.90	0.90	0.90	0.90	0.90
20	0.90	0.90	0.90	0.90	0.90	0.90	0.90	0.90	0.90	0.90	0.90	0.90
21	0.90	0.90	0.90	0.90	0.90	0.90	0.90	0.90	0.90	0.90	0.90	0.90
22	0.90	0.90	0.90	0.90	0.90	0.90	0.90	0.90	0.90	0.90	0.90	0.90
23	0.90	0.90	0.90	0.90	0.90	0.90	0.90	0.90	0.90	0.90	0.90	0.90

**Table 19 - MEDIUM shrinkage soil and LOW water demand tree**

Broad leaved trees

Foundation depth (m)												
Distance D (m)	Tree height H (m)											
	8	10	12	14	16	18	20	22	24	26	28	30
1	1.35	1.40	1.40	1.45	1.45	1.45	1.45	1.45	1.45	1.45	1.50	1.50
2	1.20	1.30	1.30	1.35	1.35	1.40	1.40	1.40	1.40	1.45	1.45	1.45
3	1.05	1.15	1.20	1.25	1.30	1.30	1.35	1.35	1.35	1.40	1.40	1.40
4	0.90	1.05	1.10	1.20	1.20	1.25	1.30	1.30	1.30	1.35	1.35	1.35
5	0.90	0.90	1.00	1.10	1.15	1.20	1.20	1.25	1.25	1.30	1.30	1.30
6	0.90	0.90	0.90	1.00	1.05	1.10	1.15	1.20	1.20	1.25	1.25	1.30
7	0.90	0.90	0.90	0.90	1.00	1.05	1.10	1.15	1.15	1.20	1.20	1.25
8	0.90	0.90	0.90	0.90	0.90	1.00	1.05	1.10	1.10	1.15	1.20	1.20
9	0.90	0.90	0.90	0.90	0.90	0.90	1.00	1.05	1.05	1.10	1.15	1.15
10	0.90	0.90	0.90	0.90	0.90	0.90	0.90	0.95	1.00	1.05	1.10	1.10
11	0.90	0.90	0.90	0.90	0.90	0.90	0.90	0.90	0.95	1.00	1.05	1.10
12	0.90	0.90	0.90	0.90	0.90	0.90	0.90	0.90	0.90	0.95	1.00	1.05
13	0.90	0.90	0.90	0.90	0.90	0.90	0.90	0.90	0.90	0.90	0.95	1.00
14	0.90	0.90	0.90	0.90	0.90	0.90	0.90	0.90	0.90	0.90	0.90	0.95
15	0.90	0.90	0.90	0.90	0.90	0.90	0.90	0.90	0.90	0.90	0.90	0.90

4.2

**Table 20 - LOW shrinkage soil and HIGH water demand tree**

**Broad leaved trees**

Distance D (m)	Foundation depth (m)											
	Tree height H (m)											
	8	10	12	14	16	18	20	22	24	26	28	30
1	2.35	2.40	2.40	2.40	2.45	2.45	2.45	2.45	2.45	2.45	2.45	2.45
2	2.15	2.25	2.30	2.30	2.35	2.35	2.40	2.40	2.40	2.40	2.40	2.45
3	2.00	2.10	2.15	2.20	2.25	2.30	2.30	2.35	2.35	2.35	2.35	2.40
4	1.80	1.95	2.05	2.10	2.15	2.20	2.25	2.25	2.30	2.30	2.30	2.35
5	1.65	1.80	1.95	2.00	2.10	2.15	2.15	2.20	2.25	2.25	2.25	2.30
6	1.45	1.70	1.80	1.90	2.00	2.05	2.10	2.15	2.15	2.20	2.20	2.25
7	1.30	1.55	1.70	1.80	1.90	2.00	2.05	2.05	2.10	2.15	2.15	2.20
8	1.10	1.40	1.60	1.70	1.80	1.90	1.95	2.00	2.05	2.10	2.10	2.15
9	0.95	1.25	1.45	1.60	1.75	1.80	1.90	1.95	2.00	2.05	2.05	2.10
10	0.75	1.10	1.35	1.50	1.65	1.75	1.80	1.90	1.95	2.00	2.00	2.05
11	0.75	1.00	1.20	1.40	1.55	1.65	1.75	1.80	1.90	1.95	1.95	2.00
12	0.75	0.85	1.10	1.30	1.45	1.60	1.70	1.75	1.80	1.85	1.90	1.95
13	0.75	0.75	1.00	1.20	1.40	1.50	1.60	1.70	1.75	1.80	1.85	1.90
14	0.75	0.75	0.90	1.10	1.30	1.45	1.55	1.65	1.70	1.75	1.80	1.85
15	0.75	0.75	0.75	1.00	1.20	1.35	1.45	1.55	1.65	1.70	1.75	1.80
16	0.75	0.75	0.75	0.90	1.10	1.30	1.40	1.50	1.60	1.65	1.70	1.75
17	0.75	0.75	0.75	0.80	1.05	1.20	1.35	1.45	1.55	1.60	1.65	1.75
18	0.75	0.75	0.75	0.75	0.95	1.10	1.25	1.35	1.45	1.55	1.60	1.70
19	0.75	0.75	0.75	0.75	0.85	1.05	1.20	1.30	1.40	1.50	1.55	1.65
20	0.75	0.75	0.75	0.75	0.75	0.95	1.10	1.25	1.35	1.45	1.50	1.60
21	0.75	0.75	0.75	0.75	0.75	0.90	1.05	1.20	1.30	1.40	1.45	1.55
22	0.75	0.75	0.75	0.75	0.75	0.80	1.00	1.10	1.25	1.35	1.40	1.50
23	0.75	0.75	0.75	0.75	0.75	0.75	0.90	1.05	1.20	1.30	1.35	1.45
24	0.75	0.75	0.75	0.75	0.75	0.75	0.85	1.00	1.10	1.25	1.30	1.40
25	0.75	0.75	0.75	0.75	0.75	0.75	0.75	0.95	1.05	1.15	1.25	1.35
26	0.75	0.75	0.75	0.75	0.75	0.75	0.75	0.85	1.00	1.10	1.20	1.30
27	0.75	0.75	0.75	0.75	0.75	0.75	0.75	0.80	0.95	1.05	1.15	1.25
28	0.75	0.75	0.75	0.75	0.75	0.75	0.75	0.75	0.90	1.00	1.10	1.20
29	0.75	0.75	0.75	0.75	0.75	0.75	0.75	0.75	0.85	0.95	1.05	1.15
30	0.75	0.75	0.75	0.75	0.75	0.75	0.75	0.75	0.75	0.90	1.00	1.10
31	0.75	0.75	0.75	0.75	0.75	0.75	0.75	0.75	0.75	0.85	0.95	1.05
32	0.75	0.75	0.75	0.75	0.75	0.75	0.75	0.75	0.75	0.80	0.90	1.05
33	0.75	0.75	0.75	0.75	0.75	0.75	0.75	0.75	0.75	0.75	0.85	1.00
34	0.75	0.75	0.75	0.75	0.75	0.75	0.75	0.75	0.75	0.75	0.80	0.95
35	0.75	0.75	0.75	0.75	0.75	0.75	0.75	0.75	0.75	0.75	0.75	0.90
36	0.75	0.75	0.75	0.75	0.75	0.75	0.75	0.75	0.75	0.75	0.75	0.85
37	0.75	0.75	0.75	0.75	0.75	0.75	0.75	0.75	0.75	0.75	0.75	0.80
38	0.75	0.75	0.75	0.75	0.75	0.75	0.75	0.75	0.75	0.75	0.75	0.75

**Coniferous trees**

Distance D (m)	Foundation depth (m)											
	Tree height H (m)											
	8	10	12	14	16	18	20	22	24	26	28	30
1	2.15	2.25	2.30	2.30	2.35	2.35	2.35	2.40	2.40	2.40	2.40	2.40
2	1.80	1.95	2.05	2.10	2.15	2.20	2.25	2.25	2.30	2.30	2.30	2.35
3	1.45	1.65	1.80	1.90	1.95	2.05	2.10	2.10	2.15	2.20	2.20	2.25
4	1.05	1.35	1.55	1.70	1.80	1.85	1.95	2.00	2.05	2.05	2.10	2.15
5	0.75	1.05	1.30	1.50	1.60	1.70	1.80	1.85	1.90	1.95	2.00	2.05
6	0.75	0.75	1.05	1.25	1.45	1.55	1.65	1.70	1.80	1.85	1.90	1.95
7	0.75	0.75	0.80	1.05	1.25	1.40	1.50	1.60	1.65	1.75	1.80	1.85
8	0.75	0.75	0.75	0.85	1.05	1.20	1.35	1.45	1.55	1.60	1.70	1.75
9	0.75	0.75	0.75	0.75	0.90	1.05	1.20	1.35	1.45	1.50	1.60	1.65
10	0.75	0.75	0.75	0.75	0.75	0.90	1.05	1.20	1.30	1.40	1.50	1.55
11	0.75	0.75	0.75	0.75	0.75	0.75	0.90	1.05	1.20	1.30	1.35	1.45
12	0.75	0.75	0.75	0.75	0.75	0.75	0.75	0.95	1.05	1.15	1.25	1.35
13	0.75	0.75	0.75	0.75	0.75	0.75	0.75	0.75	0.80	0.95	1.05	1.15
14	0.75	0.75	0.75	0.75	0.75	0.75	0.75	0.75	0.75	0.80	0.95	1.05
15	0.75	0.75	0.75	0.75	0.75	0.75	0.75	0.75	0.75	0.75	0.85	0.95
16	0.75	0.75	0.75	0.75	0.75	0.75	0.75	0.75	0.75	0.75	0.75	0.85
17	0.75	0.75	0.75	0.75	0.75	0.75	0.75	0.75	0.75	0.75	0.75	0.85
18	0.75	0.75	0.75	0.75	0.75	0.75	0.75	0.75	0.75	0.75	0.75	0.75
19	0.75	0.75	0.75	0.75	0.75	0.75	0.75	0.75	0.75	0.75	0.75	0.75
20	0.75	0.75	0.75	0.75	0.75	0.75	0.75	0.75	0.75	0.75	0.75	0.75
21	0.75	0.75	0.75	0.75	0.75	0.75	0.75	0.75	0.75	0.75	0.75	0.75
22	0.75	0.75	0.75	0.75	0.75	0.75	0.75	0.75	0.75	0.75	0.75	0.75
23	0.75	0.75	0.75	0.75	0.75	0.75	0.75	0.75	0.75	0.75	0.75	0.75
24	0.75	0.75	0.75	0.75	0.75	0.75	0.75	0.75	0.75	0.75	0.75	0.75
25	0.75	0.75	0.75	0.75	0.75	0.75	0.75	0.75	0.75	0.75	0.75	0.75
26	0.75	0.75	0.75	0.75	0.75	0.75	0.75	0.75	0.75	0.75	0.75	0.75
27	0.75	0.75	0.75	0.75	0.75	0.75	0.75	0.75	0.75	0.75	0.75	0.75
28	0.75	0.75	0.75	0.75	0.75	0.75	0.75	0.75	0.75	0.75	0.75	0.75
29	0.75	0.75	0.75	0.75	0.75	0.75	0.75	0.75	0.75	0.75	0.75	0.75
30	0.75	0.75	0.75	0.75	0.75	0.75	0.75	0.75	0.75	0.75	0.75	0.75
31	0.75	0.75	0.75	0.75	0.75	0.75	0.75	0.75	0.75	0.75	0.75	0.75
32	0.75	0.75	0.75	0.75	0.75	0.75	0.75	0.75	0.75	0.75	0.75	0.75
33	0.75	0.75	0.75	0.75	0.75	0.75	0.75	0.75	0.75	0.75	0.75	0.75
34	0.75	0.75	0.75	0.75	0.75	0.75	0.75	0.75	0.75	0.75	0.75	0.75
35	0.75	0.75	0.75	0.75	0.75	0.75	0.75	0.75	0.75	0.75	0.75	0.75
36	0.75	0.75	0.75	0.75	0.75	0.75	0.75	0.75	0.75	0.75	0.75	0.75
37	0.75	0.75	0.75	0.75	0.75	0.75	0.75	0.75	0.75	0.75	0.75	0.75
38	0.75	0.75	0.75	0.75	0.75	0.75	0.75	0.75	0.75	0.75	0.75	0.75

4.2

# 4.2 Building near trees

4.2

**Table 21 - LOW shrinkage soil and MODERATE water demand tree**

Broad leaved trees

Foundation depth (m)												
Distance D (m)	Tree height H (m)											
	8	10	12	14	16	18	20	22	24	26	28	30
1	1.50	1.50	1.55	1.55	1.55	1.55	1.55	1.55	1.55	1.60	1.60	1.60
2	1.35	1.40	1.45	1.45	1.50	1.50	1.50	1.50	1.55	1.55	1.55	1.55
3	1.20	1.30	1.35	1.40	1.40	1.45	1.45	1.45	1.50	1.50	1.50	1.50
4	1.05	1.15	1.25	1.30	1.35	1.35	1.40	1.40	1.45	1.45	1.45	1.45
5	0.90	1.05	1.15	1.20	1.25	1.30	1.35	1.35	1.40	1.40	1.40	1.45
6	0.75	0.95	1.05	1.15	1.20	1.25	1.30	1.30	1.35	1.35	1.40	1.40
7	0.75	0.85	0.95	1.05	1.10	1.20	1.20	1.25	1.30	1.30	1.35	1.35
8	0.75	0.75	0.85	0.95	1.05	1.10	1.15	1.20	1.25	1.25	1.30	1.30
9	0.75	0.75	0.75	0.90	1.00	1.05	1.10	1.15	1.20	1.25	1.25	1.30
10	0.75	0.75	0.75	0.80	0.90	1.00	1.05	1.10	1.15	1.20	1.20	1.25
11	0.75	0.75	0.75	0.75	0.85	0.95	1.00	1.05	1.10	1.15	1.15	1.20
12	0.75	0.75	0.75	0.75	0.75	0.85	0.95	1.00	1.05	1.10	1.15	1.15
13	0.75	0.75	0.75	0.75	0.75	0.80	0.90	0.95	1.00	1.05	1.10	1.15
14	0.75	0.75	0.75	0.75	0.75	0.75	0.85	0.90	0.95	1.00	1.05	1.10
15	0.75	0.75	0.75	0.75	0.75	0.75	0.75	0.85	0.90	0.95	1.00	1.05
16	0.75	0.75	0.75	0.75	0.75	0.75	0.75	0.80	0.85	0.90	0.95	1.00
17	0.75	0.75	0.75	0.75	0.75	0.75	0.75	0.75	0.80	0.90	0.95	1.00
18	0.75	0.75	0.75	0.75	0.75	0.75	0.75	0.75	0.75	0.85	0.90	0.95
19	0.75	0.75	0.75	0.75	0.75	0.75	0.75	0.75	0.75	0.80	0.85	0.90
20	0.75	0.75	0.75	0.75	0.75	0.75	0.75	0.75	0.75	0.75	0.80	0.85
21	0.75	0.75	0.75	0.75	0.75	0.75	0.75	0.75	0.75	0.75	0.75	0.85
22	0.75	0.75	0.75	0.75	0.75	0.75	0.75	0.75	0.75	0.75	0.75	0.80
23	0.75	0.75	0.75	0.75	0.75	0.75	0.75	0.75	0.75	0.75	0.75	0.75

Coniferous trees

Foundation depth (m)												
Distance D (m)	Tree height H (m)											
	8	10	12	14	16	18	20	22	24	26	28	30
1	1.30	1.40	1.40	1.45	1.45	1.50	1.50	1.50	1.50	1.55	1.55	1.55
2	1.00	1.15	1.20	1.25	1.30	1.35	1.40	1.40	1.40	1.45	1.45	1.45
3	0.75	0.90	1.00	1.10	1.15	1.20	1.25	1.30	1.30	1.35	1.35	1.40
4	0.75	0.75	0.80	0.95	1.00	1.10	1.15	1.20	1.20	1.25	1.25	1.30
5	0.75	0.75	0.75	0.75	0.85	0.95	1.00	1.05	1.10	1.15	1.20	1.20
6	0.75	0.75	0.75	0.75	0.75	0.80	0.90	0.95	1.00	1.05	1.10	1.15
7	0.75	0.75	0.75	0.75	0.75	0.75	0.75	0.85	0.90	0.95	1.00	1.05
8	0.75	0.75	0.75	0.75	0.75	0.75	0.75	0.75	0.80	0.85	0.95	0.95
9	0.75	0.75	0.75	0.75	0.75	0.75	0.75	0.75	0.75	0.80	0.85	0.90
10	0.75	0.75	0.75	0.75	0.75	0.75	0.75	0.75	0.75	0.75	0.75	0.80
11	0.75	0.75	0.75	0.75	0.75	0.75	0.75	0.75	0.75	0.75	0.75	0.75
12	0.75	0.75	0.75	0.75	0.75	0.75	0.75	0.75	0.75	0.75	0.75	0.75
13	0.75	0.75	0.75	0.75	0.75	0.75	0.75	0.75	0.75	0.75	0.75	0.75
14	0.75	0.75	0.75	0.75	0.75	0.75	0.75	0.75	0.75	0.75	0.75	0.75
15	0.75	0.75	0.75	0.75	0.75	0.75	0.75	0.75	0.75	0.75	0.75	0.75
16	0.75	0.75	0.75	0.75	0.75	0.75	0.75	0.75	0.75	0.75	0.75	0.75
17	0.75	0.75	0.75	0.75	0.75	0.75	0.75	0.75	0.75	0.75	0.75	0.75
18	0.75	0.75	0.75	0.75	0.75	0.75	0.75	0.75	0.75	0.75	0.75	0.75
19	0.75	0.75	0.75	0.75	0.75	0.75	0.75	0.75	0.75	0.75	0.75	0.75
20	0.75	0.75	0.75	0.75	0.75	0.75	0.75	0.75	0.75	0.75	0.75	0.75
21	0.75	0.75	0.75	0.75	0.75	0.75	0.75	0.75	0.75	0.75	0.75	0.75
22	0.75	0.75	0.75	0.75	0.75	0.75	0.75	0.75	0.75	0.75	0.75	0.75
23	0.75	0.75	0.75	0.75	0.75	0.75	0.75	0.75	0.75	0.75	0.75	0.75

**Table 22 - LOW shrinkage soil and LOW water demand tree**

Broad leaved trees

Foundation depth (m)												
Distance D (m)	Tree height H (m)											
	8	10	12	14	16	18	20	22	24	26	28	30
1	1.10	1.15	1.15	1.15	1.15	1.15	1.20	1.20	1.20	1.20	1.20	1.20
2	1.00	1.05	1.05	1.10	1.10	1.10	1.15	1.15	1.15	1.15	1.15	1.15
3	0.90	0.95	1.00	1.05	1.05	1.05	1.10	1.10	1.10	1.10	1.10	1.15
4	0.75	0.85	0.90	0.95	1.00	1.00	1.05	1.05	1.05	1.10	1.10	1.10
5	0.75	0.75	0.85	0.90	0.95	0.95	1.00	1.00	1.05	1.05	1.05	1.05
6	0.75	0.75	0.75	0.85	0.90	0.90	0.95	0.95	1.00	1.00	1.05	1.05
7	0.75	0.75	0.75	0.75	0.85	0.85	0.90	0.95	0.95	1.00	1.00	1.00
8	0.75	0.75	0.75	0.75	0.75	0.80	0.85	0.90	0.90	0.95	0.95	1.00
9	0.75	0.75	0.75	0.75	0.75	0.75	0.80	0.85	0.90	0.90	0.95	0.95
10	0.75	0.75	0.75	0.75	0.75	0.75	0.75	0.80	0.85	0.85	0.90	0.90
11	0.75	0.75	0.75	0.75	0.75	0.75	0.75	0.75	0.80	0.85	0.85	0.90
12	0.75	0.75	0.75	0.75	0.75	0.75	0.75	0.75	0.75	0.80	0.85	0.85
13	0.75	0.75	0.75	0.75	0.75	0.75	0.75	0.75	0.75	0.75	0.80	0.85
14	0.75	0.75	0.75	0.75	0.75	0.75	0.75	0.75	0.75	0.75	0.75	0.80
15	0.75	0.75	0.75	0.75	0.75	0.75	0.75	0.75	0.75	0.75	0.75	0.75

APPENDIX 4.2-D

Climate zones

**Figure 13 Reductions in foundation depth due to climate variations**

The foundation depth may be reduced by the amounts shown on the map for each climatic zone (see Design clause D5(e)). Where it is unclear which zone applies, the lower reduction value should be used.

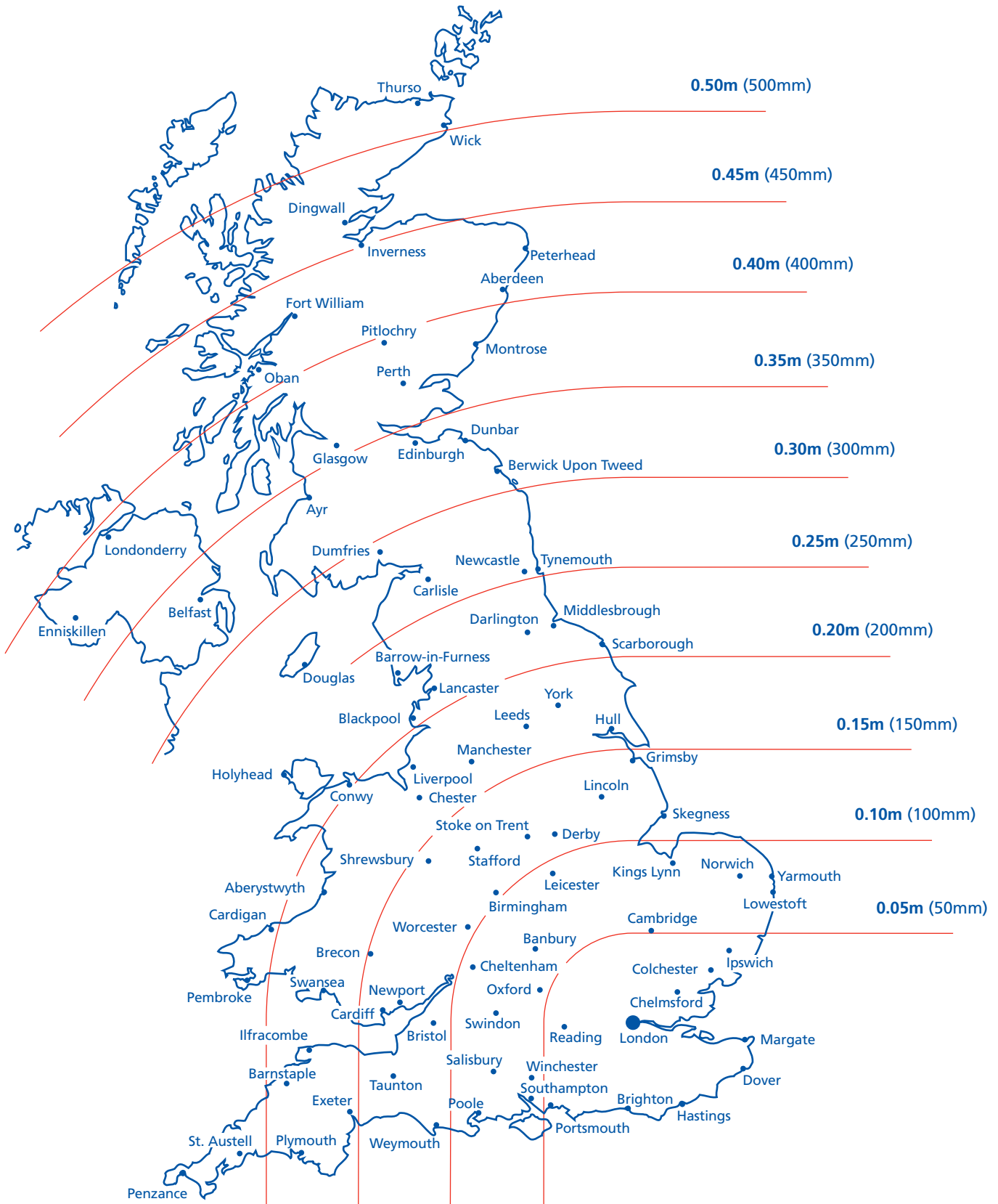

4.2

# 4.2 Building near trees

## APPENDIX 4.2-E

### Information sources and acknowledgements

#### INFORMATION SOURCES

Further recommendations and information can be obtained from:

#### Publications

BS 1377 'Methods of test for soils for civil engineering purposes'

BS 5837 'Guide for trees in relation to construction'

BS 5930 'Code of practice for site investigations'

BRE Digests 240, 241 and 242 'Low rise buildings on shrinkable clay soils', parts 1, 2 and 3

BRE Digest 298 'The influence of trees on house foundations in clay soils'

BRE Digest 412 'Desiccation in clay soils'

#### Tree Recognition - A Pocket Manual

by Ian Richardson and Rowena Gale, Richardson's Botanical Identifications, 49/51 Whiteknights Road, Reading, Berks RG6 7BB

#### Field Guide to the Trees of Britain and Northern Europe

by Alan Mitchell, Harper Collins, Glasgow

#### Geological survey maps

obtainable from British Geological Survey, Nicker Hill, Keyworth, Nottingham NG12 5GG  
Tel: 0115 936 3100; [www.bgs.ac.uk](http://www.bgs.ac.uk)

#### Tree root damage to buildings

##### Vol.1 Causes, Diagnosis and Remedy

##### Vol. 2 Patterns of Soil Drying in

##### Proximity to Trees on Clay Soils

by P G Biddle, Willowmead Publishing, Wantage OX12 9JA

#### Organisations

##### Arboricultural Association

Ampfield House, Ampfield, nr. Romsey, Hants SO51 9PA  
Tel: 01794 368717; [www.trees.org.uk](http://www.trees.org.uk)

##### Arboricultural Advisory and Information Service

Forest Research Station, Alice Holt Lodge, Wrecclesham, Farnham, Surrey GU10 4LH  
Tel: 01420 22022; [www.treehelp.info](http://www.treehelp.info)  
(Tree Helpline telephone no. 0906 516 1147)

##### Institution of Civil Engineers

1-7 Great George Street, London SW1P 3AA  
Tel: 020 7222 7722; [www.ice.org.uk](http://www.ice.org.uk)

##### Institution of Structural Engineers

11 Upper Belgrave Street, London SW1X 8BH  
Tel: 020 7235 4535; [www.istructe.org.uk](http://www.istructe.org.uk)

#### ACKNOWLEDGEMENTS

NHBC gratefully acknowledges the help given by authoritative organisations and individuals in the preparation of this Chapter, particularly:  
Building Research Establishment  
Dr P G Biddle Arboricultural Consultant

**APPENDIX 4.2-F**

**Worked example**

How to determine foundation depths from the Charts in Appendix 4.2-B or the Tables in Appendix 4.2-C.

Step		Ref	Example				
1	<b>Determine the volume change potential of the soil.</b> Ensure the site investigation includes representative sampling and testing.	D5(b)	<p>Site at Oxford, building near a Lombardy Poplar (to be retained) and a Sycamore (to be removed)</p> <p>From laboratory tests,</p> <p><b>Plasticity Index, <math>I_p = 36\%</math>.</b></p> <p>Test results also report that 100% of particles are smaller than <math>425\mu\text{m}</math>. Therefore,</p> <p><b>modified Plasticity Index, <math>I'_p = \frac{36 \times 100}{100} = 36\%</math></b></p> <p>From Table 1, <b>Volume change potential = Medium</b> (in the absence of tests assume high volume change potential)</p> <p><i>This example is typical of Oxford Clay. More than 35% of the particles are smaller than <math>60\mu\text{m}</math> and therefore the soil is shrinkable. 100% of the particles are smaller than <math>425\mu\text{m}</math> and therefore the <math>I'_p</math> is the same as the <math>I_p</math>.</i></p> <p><i>A typical Boulder Clay also has more than 35% of particles smaller than <math>60\mu\text{m}</math> and is therefore also shrinkable. However, it may have only 80% of its particles smaller than <math>425\mu\text{m}</math> in which case the <math>I'_p</math> is 80% of the <math>I_p</math>.</i></p> <p><i>A typical clayey sand may have less than 30% of its particles smaller than <math>60\mu\text{m}</math> in which case the soil would be non shrinkable.</i></p>				
2	<b>Establish the species, mature height and water demand</b> of all trees and hedgerows within their influencing radii.	D5(c) and D5(d)	<table border="1"> <tr> <td>Lombardy Poplar</td> <td>Sycamore</td> </tr> <tr> <td>From Appendix 4.2-A <b>Mature height = 25m</b> <b>Water demand = High</b></td> <td>From Appendix 4.2-A <b>Mature height = 22m</b> <b>Water demand = Moderate</b></td> </tr> </table>	Lombardy Poplar	Sycamore	From Appendix 4.2-A <b>Mature height = 25m</b> <b>Water demand = High</b>	From Appendix 4.2-A <b>Mature height = 22m</b> <b>Water demand = Moderate</b>
Lombardy Poplar	Sycamore						
From Appendix 4.2-A <b>Mature height = 25m</b> <b>Water demand = High</b>	From Appendix 4.2-A <b>Mature height = 22m</b> <b>Water demand = Moderate</b>						
3	<b>Plot the trees and hedgerows relative to the foundations and draw their zones of influence</b> to determine which trees will affect the foundation design. Use a scaled plan.	D5(c)	<p>The diagram shows a house represented by a grey rectangle. Two trees are shown: a Lombardy Poplar (mature height 25m) and a Sycamore (mature height 22m). The zone of influence for the Lombardy Poplar is a circle with a radius of 31.25m (calculated as 1.25 x 25). The zone of influence for the Sycamore is a smaller circle with a radius of 16.5m (calculated as 0.75 x 22). The distance from the house to the center of the Lombardy Poplar is 10m, and the distance to the center of the Sycamore is 8m.</p>				
4	<b>Establish the appropriate tree height H to use.</b> Always use the mature height for remaining and proposed trees and hedgerows. The appropriate height to use for removed trees and hedgerows depends on the actual height when they are removed.	D5(d)	<table border="1"> <tr> <td>Lombardy Poplar</td> <td>Sycamore</td> </tr> <tr> <td>Tree to remain. Therefore, <b>H = Mature height = 25m</b></td> <td>Tree to be removed <b>Mature height = 22m</b> <b>Actual height = 15m</b> Actual height greater than 50% mature height. Therefore, <b>H = Mature height = 22m</b></td> </tr> </table>	Lombardy Poplar	Sycamore	Tree to remain. Therefore, <b>H = Mature height = 25m</b>	Tree to be removed <b>Mature height = 22m</b> <b>Actual height = 15m</b> Actual height greater than 50% mature height. Therefore, <b>H = Mature height = 22m</b>
Lombardy Poplar	Sycamore						
Tree to remain. Therefore, <b>H = Mature height = 25m</b>	Tree to be removed <b>Mature height = 22m</b> <b>Actual height = 15m</b> Actual height greater than 50% mature height. Therefore, <b>H = Mature height = 22m</b>						
5	<b>Measure the distance D</b> from the centre of the trees or hedgerows to the face of the foundation.	D6(c)	<table border="1"> <tr> <td>Lombardy Poplar</td> <td>Sycamore</td> </tr> <tr> <td><b>Distance D = 10m from foundation</b></td> <td><b>Distance D = 8m from foundation</b></td> </tr> </table>	Lombardy Poplar	Sycamore	<b>Distance D = 10m from foundation</b>	<b>Distance D = 8m from foundation</b>
Lombardy Poplar	Sycamore						
<b>Distance D = 10m from foundation</b>	<b>Distance D = 8m from foundation</b>						
6	Select Steps <b>6C(a) and (b)</b> if using <b>Charts in Appendix 4.2-B</b> to derive depths or select <b>Step 6T</b> if using <b>Tables in Appendix 4.2-C</b> to derive depths. Alternatively the NHBC foundation depth calculator may be used (see Sitework clause S2).						

4.2

# 4.2 Building near trees

4.2

<b>6C (a)</b>	<b>Calculate D/H</b> i.e. distance D from face of foundation (Step 5) divided by the appropriate tree height H (Step 4). Alternatively D/H can be obtained from Table 13 in Appendix 4.2-B.		Lombardy Poplar $\frac{D}{H} = \frac{10}{25} = 0.4$	Sycamore $\frac{D}{H} = \frac{8}{22} = 0.36$																														
<b>6C(b)</b>	<b>Determine foundation depth</b> using the Charts in Appendix 4.2-B as follows: <table border="1" data-bbox="213 495 655 674"> <thead> <tr> <th>Volume change potential</th> <th>Chart number</th> </tr> </thead> <tbody> <tr> <td>High</td> <td>1</td> </tr> <tr> <td>Medium</td> <td>2</td> </tr> <tr> <td>Low</td> <td>3</td> </tr> </tbody> </table>	Volume change potential	Chart number	High	1	Medium	2	Low	3		<table border="1" data-bbox="761 434 1109 674"> <thead> <tr> <th>Lombardy Poplar</th> <th>Sycamore</th> </tr> </thead> <tbody> <tr> <td>In this example the volume change potential is <b>Medium</b>, then from <b>Chart 2</b> for broadleaved high water demand trees at <math>\frac{D}{H} = 0.4</math>, <b>Foundation depth = 2.33m</b></td> <td>In this example the volume change potential is <b>Medium</b>, then from <b>Chart 2</b> for broadleaved moderate water demand trees at <math>\frac{D}{H} = 0.36</math>, <b>Foundation depth = 1.50m</b></td> </tr> <tr> <td colspan="2"><b>The Lombardy Poplar is the tree requiring the greater depth (2.33m)</b></td> </tr> </tbody> </table>	Lombardy Poplar	Sycamore	In this example the volume change potential is <b>Medium</b> , then from <b>Chart 2</b> for broadleaved high water demand trees at $\frac{D}{H} = 0.4$ , <b>Foundation depth = 2.33m</b>	In this example the volume change potential is <b>Medium</b> , then from <b>Chart 2</b> for broadleaved moderate water demand trees at $\frac{D}{H} = 0.36$ , <b>Foundation depth = 1.50m</b>	<b>The Lombardy Poplar is the tree requiring the greater depth (2.33m)</b>																		
Volume change potential	Chart number																																	
High	1																																	
Medium	2																																	
Low	3																																	
Lombardy Poplar	Sycamore																																	
In this example the volume change potential is <b>Medium</b> , then from <b>Chart 2</b> for broadleaved high water demand trees at $\frac{D}{H} = 0.4$ , <b>Foundation depth = 2.33m</b>	In this example the volume change potential is <b>Medium</b> , then from <b>Chart 2</b> for broadleaved moderate water demand trees at $\frac{D}{H} = 0.36$ , <b>Foundation depth = 1.50m</b>																																	
<b>The Lombardy Poplar is the tree requiring the greater depth (2.33m)</b>																																		
<b>6T</b>	<b>Determine foundation depth</b> using the Tables in Appendix 4.2-C as follows: <table border="1" data-bbox="213 804 655 1167"> <thead> <tr> <th>Volume change potential</th> <th>Tree water demand</th> <th>Table number</th> </tr> </thead> <tbody> <tr> <td rowspan="3">High</td> <td>High</td> <td>14</td> </tr> <tr> <td>Moderate</td> <td>15</td> </tr> <tr> <td>Low</td> <td>16</td> </tr> <tr> <td rowspan="3">Medium</td> <td>High</td> <td>17</td> </tr> <tr> <td>Moderate</td> <td>18</td> </tr> <tr> <td>Low</td> <td>19</td> </tr> <tr> <td rowspan="3">Low</td> <td>High</td> <td>20</td> </tr> <tr> <td>Moderate</td> <td>21</td> </tr> <tr> <td>Low</td> <td>22</td> </tr> </tbody> </table>	Volume change potential	Tree water demand	Table number	High	High	14	Moderate	15	Low	16	Medium	High	17	Moderate	18	Low	19	Low	High	20	Moderate	21	Low	22		<table border="1" data-bbox="761 743 1109 1016"> <thead> <tr> <th>Lombardy Poplar</th> <th>Sycamore</th> </tr> </thead> <tbody> <tr> <td>In this example the volume change potential is <b>Medium</b> and the water demand is <b>High</b>, then from <b>Table 17</b>, for broad leaved high water demand trees at D = 10m and H = 25m, <b>Foundation depth = 2.33m (by interpolation)</b></td> <td>In this example the volume change potential is <b>Medium</b> and the water demand is <b>Moderate</b>, then from <b>Table 18</b>, for broad leaved moderate water demand trees at D = 8m and H = 22m, <b>Foundation depth = 1.50m</b></td> </tr> <tr> <td colspan="2"><b>The Lombardy Poplar is the tree requiring the greater depth (2.33m)</b></td> </tr> </tbody> </table>	Lombardy Poplar	Sycamore	In this example the volume change potential is <b>Medium</b> and the water demand is <b>High</b> , then from <b>Table 17</b> , for broad leaved high water demand trees at D = 10m and H = 25m, <b>Foundation depth = 2.33m (by interpolation)</b>	In this example the volume change potential is <b>Medium</b> and the water demand is <b>Moderate</b> , then from <b>Table 18</b> , for broad leaved moderate water demand trees at D = 8m and H = 22m, <b>Foundation depth = 1.50m</b>	<b>The Lombardy Poplar is the tree requiring the greater depth (2.33m)</b>		
Volume change potential	Tree water demand	Table number																																
High	High	14																																
	Moderate	15																																
	Low	16																																
Medium	High	17																																
	Moderate	18																																
	Low	19																																
Low	High	20																																
	Moderate	21																																
	Low	22																																
Lombardy Poplar	Sycamore																																	
In this example the volume change potential is <b>Medium</b> and the water demand is <b>High</b> , then from <b>Table 17</b> , for broad leaved high water demand trees at D = 10m and H = 25m, <b>Foundation depth = 2.33m (by interpolation)</b>	In this example the volume change potential is <b>Medium</b> and the water demand is <b>Moderate</b> , then from <b>Table 18</b> , for broad leaved moderate water demand trees at D = 8m and H = 22m, <b>Foundation depth = 1.50m</b>																																	
<b>The Lombardy Poplar is the tree requiring the greater depth (2.33m)</b>																																		
<b>7</b>	<b>Adjust the depth according to the climatic zone.</b> A reduction may be made for distance north and west of London but the final depth should not be less than the minimum given in each Chart and Table.	D5(e)	Oxford is between 50 and 100 miles NW of London. From Appendix 4.2-D, a reduction of 0.05m is permitted. <b>Final foundation depth = 2.33 - 0.05 = 2.28m</b>																															
<b>8</b>	<b>Check that the recommendations of this Chapter have been met for:</b>  <b>Acceptable foundation types</b>  <b>New planting</b> (including shrubs)  <b>Non shrinkable soil overlying shrinkable soil</b>  <b>Variations in foundation depths</b>  <b>Foundations on sloping ground</b>  <b>Precautions against heave</b> (including suspended floors)  <b>Measurement of foundation depths</b>  <b>Foundation trench bottoms</b>  <b>Precautions for drainage</b>	D6(a)  D6(d), D6(e)  D6(f)  D6(g), S3(b)  D6(h)  D8,S4  S3(a)  S3(c)  S5																																

**Note:**  
The above process may be repeated to allow the foundation to be stepped as its distance from the tree increases.



**INDEX**

<b>B</b>		<b>M</b>		<b>T</b>	
Broad leafed trees	8, 13-18	Modified Plasticity Index	1, 10, 11, 21	Tree heights	2, 6, 8, 13-18
<b>C</b>		<b>N</b>		Tree species	8
Climate	2, 19	New planting	3	Trench bottoms	6
Compressible materials	5, 6, 7	<b>P</b>		Trench fill foundations	2, 4, 6
Coniferous trees	8, 13-18	Pier and beam foundations	2, 4, 7	<b>V</b>	
<b>D</b>		Pile and beam foundations	2, 4, 7	Void formers	5, 7
Depth charts	9-12	Plasticity Index	1, 10, 11, 21	Volume change potential	1
Depth Tables	13-18	Protection of trees	1	<b>W</b>	
Drainage	5, 7, 21, 22	<b>R</b>		Water demand	1, 8, 13-18
<b>E</b>		Raft foundations	2, 4, 5	<b>Z</b>	
Excavation	6	<b>S</b>		Zone of influence	2, 21
<b>F</b>		Shrinkable soils	1, 3, 13-18		
Foundation depths	2, 3, 6, 9-18	Shrubs	3		
Foundation types	2, 4	Sloping ground	3		
<b>H</b>		Soil classification	1		
Heave	1, 4, 5, 6, 7	Stepped foundations	2, 6		
Heave precautions	4, 5, 6, 7	Strip foundations	2, 3		
		Suspended ground floors	5		



# Chapter 4.4

## Strip and trench fill foundations

---



# 4.4 Strip and trench fill foundations

## CONTENTS

	Clause	Page
<b>DESIGN</b>		
Design standard	D1	1
Statutory requirements	D2	1
Requirement for foundations	D3	1
Safe transmission of loads	D4	1
Design by an Engineer	D5-D6	1
Site conditions	D7	1
Foundation depth	D8	1
Stepped foundations	D9	2
Services and drainage	D10	2
Movement joints	D11	2
Provision of information	D12-D13	2
<b>MATERIALS</b>		
Materials standards	M1	2
Concrete	M2	2
Reinforcement	M3	2
Other materials	M4	2
<b>SITWORK</b>		
Sitework standards	S1	2
Setting out foundations	S2	3
Excavations	S3-S8	3
Services and drainage	S9-S10	3
General construction	S11-S12	4
Strip and trench fill foundations	S13	4
<b>APPENDIX 4.4-A</b>		
Dimensions of strip foundations		6
<b>INDEX</b>		7

## SCOPE

This Chapter gives guidance on meeting the Technical Requirements and recommendations for strip and trench fill foundations.

## DESIGN STANDARDS

### 4.4 - D1 Design shall meet the Technical Requirements

Design that follows the guidance below will be acceptable for both strip foundations and trench fill foundations.

## STATUTORY REQUIREMENTS

### 4.4 - D2 Design shall comply with all relevant statutory requirements

Design should be in accordance with relevant Building Regulations and other statutory requirements.

## REQUIREMENT FOR FOUNDATIONS

### 4.4 - D3 All loadbearing elements shall be adequately supported by foundations

Elements requiring foundations include the following:

- external walls
- separating (party) walls
- chimney breasts
- piers
- internal loadbearing walls.

#### SLEEPER WALLS

In Scotland, a sleeper wall is also defined as a loadbearing element and must be provided with a suitable foundation.

In England, Wales, Northern Ireland and the Isle of Man, sleeper walls should not be built off oversite concrete:

- on shrinkable clay soils where heave could take place
- where infill below the oversite concrete is greater than 600mm
- which is less than 100mm thick.

In these situations, suitable foundations will be required.

## SAFE TRANSMISSION OF LOADS

### 4.4 - D4 Foundations shall be designed to transmit loads to the ground safely and without excessive settlement

Items to be taken into account include:

#### (a) dead and imposed loads

Dead and imposed loads should be calculated in accordance with BS EN 1991-1-1, BS EN 1991-1-3, BS EN 1991-1-4 and BS 648.

Appendix 4.4-A shows suitable foundation dimensions and gives minimum widths of strip foundations for different sub-soil and wall loadings. Strip foundations should be 150mm to 500mm thick. Trench fill foundations should be greater than 500mm thick.

### (b) stability of the dwelling and any associated constructions

Where appropriate, reference should be made to BS 8103.

Unless there are reasons for doing otherwise, foundations should be symmetrical beneath loadbearing elements.

Strip and trench fill foundations should be continuous throughout the building, including integral garages, porches, conservatories, bay windows, etc. The foundations should be of sufficient width throughout to avoid overstressing the ground, especially where the foundation is required to support piers or columns.

Reference should be made to Chapter 4.2 'Building near trees' where:

- soil is shrinkable
- trees have been, or are being, removed since heave is possible in these situations special precautions are necessary.

The width of the foundation will depend on the loadbearing capacity of the sub-soil and the loads from the building. However, the foundation width should not be less than the wall thickness, plus at least 50mm each side, to ensure that the foundation is not oversailed by any part of the wall.

### (c) stability of any adjoining dwelling or construction

Foundations adjoining those of an existing building may require special design. If taken to a greater depth, such foundations will usually need to be Engineer designed and carefully supervised to check the standard of workmanship. Where necessary, allowance should be made in the design for differential movement.

## DESIGN BY AN ENGINEER

### 4.4 - D5 Foundations on hazardous ground shall be designed by an Engineer

Details of hazardous ground to be taken into consideration are given in Chapters: 4.1 'Land quality - managing ground conditions', and 4.2 'Building near trees'.

Foundations should be designed by an Engineer in accordance with Technical Requirement R5 where:

- buildings exceed 3 storeys in height
- retaining walls are required for habitable rooms below ground.

### 4.4 - D6 Where foundations are on hazardous ground, notice shall be given to NHBC before work starts on site

Where hazardous ground has been identified, NHBC must be notified before

work starts. Hazardous ground is defined in Chapter 4.1 'Land quality - managing ground conditions'.

NHBC Rules state:

"If a Home is to be constructed on a Hazardous Site you must before making an Application for Inspection notify the NHBC in writing of the particular hazards which arise. You must do this at least 8 weeks before work begins on the site."

## SITE CONDITIONS

### 4.4 - D7 Foundation design shall take account of site conditions

Items to be taken into account include:

#### (a) the results of site appraisal

All relevant information about the nature and loadbearing capacity of the ground should be available before the foundations are designed.

Information about ground conditions and the past history of the site may be available from a number of sources. These include NHBC, Local Authorities and the area offices of the Gas, Water and Electricity Companies. Aerial photographs, Ordnance Survey maps and geological maps and surveys may often be studied at local Public Libraries and Record Offices.

Site assessment surveys may require supplementary site investigations involving trial pits and borings. Details are given in Chapter 4.1 'Land quality - managing ground conditions'.

#### (b) dwelling design and layout

Foundation design is governed by the shape and size of the dwellings as well as the site conditions. Foundations for terraced dwellings may require special precautions to prevent damage from differential settlement.

#### (c) site levels

Stepped foundations or suspended floors may be needed for sloping sites. Reference should be made to Clause D9 for stepped foundations and to Chapter 5.2 'Suspended ground floors' (Design).

## FOUNDATION DEPTH

### 4.4 - D8 Foundation depth shall be adequate for the site conditions

Items to be taken into account include:

#### (a) soils with volume change potential

In shrinkable soils that are classified as containing more than 35% fine particles (clay and silt), and have a modified Plasticity Index of 10% or greater, the minimum foundation depth should be as in the following table:

# 4.4 Strip and trench fill foundations

Modified Plasticity Index	Volume change potential	Minimum depth (m)
40% and greater	High	1.0
20% to less than 40%	Medium	0.9
10% to less than 20%	Low	0.75

## (b) frost susceptible soils

To avoid damage from frost action, the depth to the underside of the foundation in frost susceptible ground, eg chalk, should be at least 450mm below finished ground level.

This depth should also be used when construction is undertaken during cold weather. Alternatively, precautions should be taken to prevent freezing of the ground.

## (c) suitable bearing strata

The depth of foundations should be such as to give a clean, firm and adequate bearing for the design loads.

Trench fill foundations greater than 2.5m in depth must be designed by an Engineer in accordance with Technical Requirement R5.

## STEPPED FOUNDATIONS

### 4.4 - D9 Foundations shall be taken to a suitable bearing level when building on sloping ground

Sloping ground may require stepped foundations.

Where foundations are stepped, the height of the step should not exceed the thickness of the foundation, unless it forms part of a foundation designed by an Engineer in accordance with Technical Requirement R5.

For details of stepped foundations, reference should be made to Sitework Clause 4.4 - S13(b).

## SERVICES AND DRAINAGE

### 4.4 - D10 Foundation design shall make allowance for drainage and other services

Items to be taken into account include:

#### (a) ground water drainage

Provision should be made for adjusting any existing ground water drains affected by excavation work.

#### (b) existing services

Precautions should be taken to accommodate the effects of settlement, where drains run under or near a building.

#### (c) access for services

Where services are to pass through or under foundations, provision should be made for suitable ducts or lintels to enable them to be installed later.

Reference should be made to Chapters 8.1 'Internal services' (Design and Sitework) and 5.3 'Drainage below ground' (Design and Sitework) for further details.

## MOVEMENT JOINTS

### 4.4 - D11 Movement joints shall be suitable for their intended purpose

Where movement joints are specified in foundations, they should be continuous with those in the superstructure.

## PROVISION OF INFORMATION

### 4.4 - D12 Drawings and specifications shall be produced in a clearly understandable format

It is important that all relevant information needed for the completion of the sitework is stated clearly and unambiguously and is readily available to all concerned.

All necessary dimensions and levels should be indicated and related to:

- at least one benchmark, and
- reference points on site.

All necessary details of junctions, steps, movement joints and, where necessary, any critical sequences of construction should be provided.

### 4.4 - D13 Designs and specifications, together with relevant site information, shall be distributed to appropriate personnel

Both designers and site operatives need to be aware of the ground conditions and, in particular, any features requiring special attention, such as any existing sewers or other services, levels of water table and the presence of any deleterious substances, especially sulfates.

Information on ground conditions, the results of site investigation and the foundation design can be requested by NHBC, even for those sites which are not classified as hazardous.

Where toxic materials (or materials likely to present a health hazard) are found, all available information should be supplied to NHBC, together with proposals for dealing with the hazard.

## MATERIALS STANDARDS

### 4.4 - M1 All materials shall: (a) meet the Technical Requirements (b) take account of the design

Materials that comply with the design and the guidance below will be acceptable for both strip foundations and trench fill foundations.

Materials for strip and trench fill foundations should comply with all relevant standards, including those listed below. Where no standard exists, Technical Requirement R3 applies (see Chapter 1.1 'Introduction to the Standards and Technical Requirements').

References to British Standards and Codes of Practice include those made under the Construction Products Directive (89/106/EEC) and, in particular, appropriate European Technical Specifications approved by a European Committee for Standardisation (CEN).

## CONCRETE

### 4.4 - M2 Concrete shall be of a mix design which is suitable for the intended use

Items to be taken into account include:

- (a) strength to safely transmit loads
- (b) durability against chemical or frost action

For guidance on the specification and use of concrete, particularly in relation to the choice of mix to resist deterioration due to ground aggressivity, reference should be made to Chapter 2.1 'Concrete and its reinforcement' (each section).

## REINFORCEMENT

### 4.4 - M3 Reinforcement shall be sufficient to ensure proper transfer of loads

Where reinforcement may be necessary, for example at construction joints or over small localised soft spots or changes in bearing strata, it should be in accordance with Chapter 2.1 'Concrete and its reinforcement' (each section).

## OTHER MATERIALS

### 4.4 - M4 Compressible materials shall be capable of absorbing potential heave forces, where appropriate

Proprietary materials should have been assessed in accordance with Technical Requirement R3.

## SITWORK STANDARDS

### 4.4 - S1 All sitework shall: (a) meet the Technical Requirements (b) take account of the design (c) follow established good practice and workmanship

Sitework that complies with the design and the guidance below will be acceptable for both strip foundations and trench fill foundations.

### SETTING OUT FOUNDATIONS

#### 4.4 - S2 The setting out of foundations shall take account of the design details

The accuracy of setting out should be checked by control measurements of trenches, including their location relative to site boundaries and adjacent buildings. Levels should be checked against bench marks, where appropriate.

In particular, for excavations check:

- trench lengths
- trench widths
- length of diagonals between external corners.

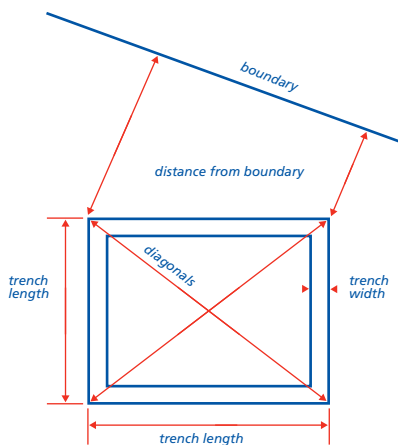

Walls should be located centrally on the foundation, unless specifically designed otherwise.

Any discrepancy in dimensions should be reported promptly to the designer. Resulting variations should be distributed to all concerned with sitework, including NHBC, where appropriate.

### EXCAVATIONS

#### 4.4 - S3 Excavations for foundations shall take account of design dimensions

Excess excavation should be avoided. Inaccuracy may prevent walls and piers being located centrally and therefore result in eccentric loading of foundations and possible foundation failure.

Accurate trench digging is particularly important where the width of the foundation is only slightly wider than the wall to be supported.

Any ground condition that might cause the foundation design to be modified should be reported promptly to the designer.

#### 4.4 - S4 Excavation shall be to a depth that gives adequate bearing and protection from frost damage

To avoid damage from frost action, the depth of foundation in frost susceptible

ground should be at least 450mm below ground level. If finished ground level is to be above existing ground level then, in cold conditions when freezing is expected, the foundation depth should be taken from the existing, not finished, ground level.

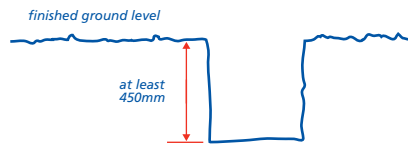

#### 4.4 - S5 Excavation in shrinkable soil shall take account of the foundation design

The design should specify the minimum foundation depth. In shrinkable soils, the minimum foundation depth should be as in the following table:

Volume change potential	Minimum depth (m)
High	1.0
Medium	0.9
Low	0.75

These minimum depths may only be used where any existing or proposed trees or shrubs are outside the zone of tree influence (See Chapter 4.2 'Building near trees' (Design)).

#### 4.4 - S6 Excavations shall take account of localised effects

Where localised changes in strata give rise to differences in bearing capacity, special precautions will be necessary and reference should be made to the designer.

At soft spots, excavations should be deepened locally to a sound bottom or, alternatively, the concrete should be reinforced.

Hard spots should be removed.

Where roots are visible on the sides or bottoms of trenches (especially in clay soils), excavations may need to be taken deeper, or special precautions determined by an Engineer in accordance with Technical Requirement R5.

On sites where there are or have been trees, foundations constructed in accordance with the guidance given in Chapter 4.2 'Building near trees' will be acceptable to NHBC.

#### 4.4 - S7 The shape of the trench shall not impair the performance of the foundation

Unless otherwise designed by an Engineer in accordance with Technical Requirement R5, trench bottoms should be horizontal with all loose material removed. Trench sides and steps should be, as near as possible, vertical.

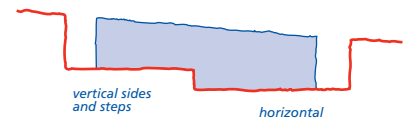

#### 4.4 - S8 Trench bottoms, when prepared for concreting, shall be compact, reasonably dry and even

If any part of a trench bottom is affected by rainwater, ground water or drying, it should be re-bottomed.

Trenches should be kept free of water.

### SERVICES AND DRAINAGE

#### 4.4 - S9 Existing services shall be adequately protected

Any existing services, such as cables, water pipes or gas mains, may need to be supported and protected.

Drains which are redundant should be cut open and filled or removed.

Any existing drains should be diverted or adequately protected.

Services should not be rigidly encased in the foundations.

Ground water drains should be diverted.

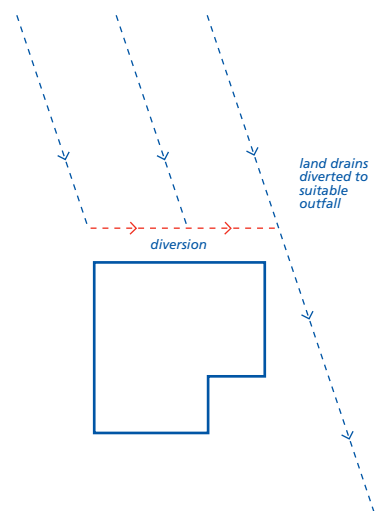

#### 4.4 - S10 Provision shall be made for service entries or services to safely pass through, or above, foundations

For details of underground drains and services, reference should be made to Chapters 8.1 'Internal services' (Design and Sitework) and 5.3 'Drainage below ground' (Design and Sitework). Reference should also be made to Chapter 5.1 'Substructure and ground bearing floors' (Design and Sitework).

#### STRIP FOUNDATIONS

Services should not pass through strip foundations but through the masonry above. Adequate lintels should be provided

# 4.4 Strip and trench fill foundations

in the masonry. Reference should be made to Chapter 5.1 'Substructure and ground bearing floors' (Design and Sitework).

## TRENCH FILL FOUNDATIONS

Where services pass through trench fill foundations, they should not affect the ability of the foundations to carry loads. Services should be either sleeved or passed through a suitably strengthened opening in the foundation. This is to ensure that differential movement will not damage services.

In the case of drains, it is important to leave sufficient space for movement to ensure that the drain is capable of maintaining line and gradient.

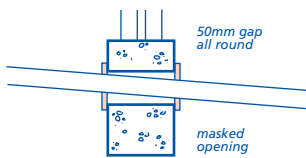
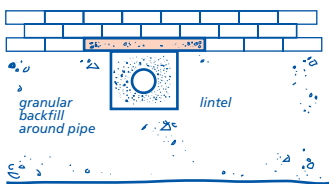
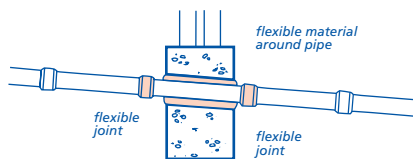

## GENERAL CONSTRUCTION

### 4.4 - S11 Concrete shall be correctly mixed, placed and cured

Concreting should be carried out, as far as possible, in one operation, taking account of weather conditions and available daylight. Concrete should be placed as soon as possible after the excavation has been checked.

Mixing, placing, testing and curing of concrete should be carried out as indicated in Chapter 2.1 'Concrete and its reinforcement' (each section), and for work carried out in cold weather, Chapter 1.4 'Cold weather working'.

The foundation thickness should be:

- 150mm to 500mm - for strip foundation
- not less than 500mm - for trench fill foundations.

Where trench fill foundations are in excess of 2.5m depth, they must be designed by an Engineer in accordance with Technical Requirement R5.

For trench fill, it is particularly important to check that the finished foundation level is correct and horizontal. It will be difficult to adjust for discrepancies in the small number of brick courses (possibly only 6) between foundation and dpc level.

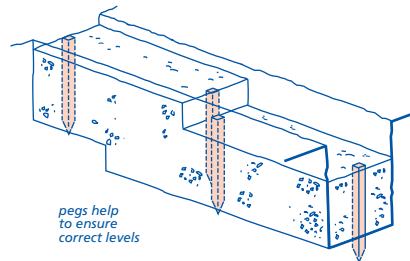

### 4.4 - S12 Strip and trench fill foundations shall be reinforced, where necessary, to suit localised ground conditions

Reinforcement, if needed, should be clean and free from loose rust and should be placed correctly. Bars, of an appropriate size, should be properly supported to ensure that they are 75mm above the base of the foundation or as indicated in the design. They should be secured at laps and crossings.

If in doubt about any soft spots, the designer's advice should be taken before placing the concrete.

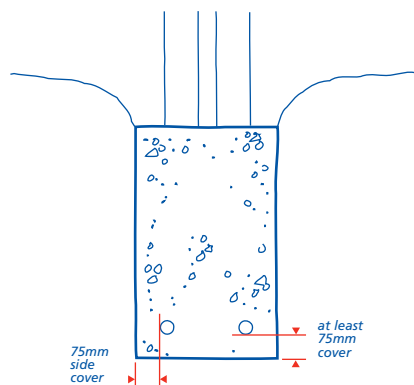

## STRIP AND TRENCH FILL FOUNDATIONS

### 4.4 - S13 Strip and trench fill foundations shall be constructed to take account of the foundation design

Items to be taken into account include:

(a) construction joints

#### STRIP FOUNDATIONS

If construction joints are unavoidable, they should not be positioned near a return in the foundation. All shuttering should be removed before work continues beyond the construction joint. For strip foundations, construction joints may be formed by one of the methods shown below.

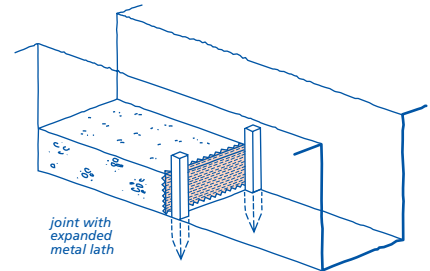
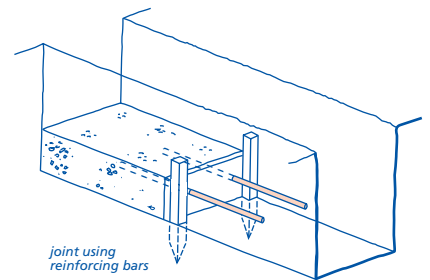

#### TRENCH FILL FOUNDATIONS

It is important that concrete mix, workability and placement are maintained throughout a trench fill foundation. However, where a joint is unavoidable, it should not be positioned near a return in the foundation. Before work continues beyond the construction joint, all shuttering should be removed. Construction joints may be formed by one of the methods shown below.

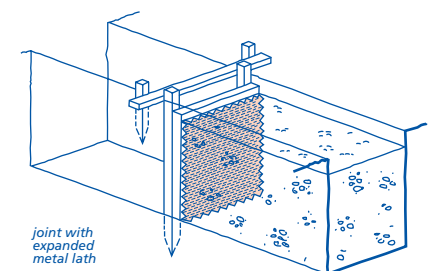
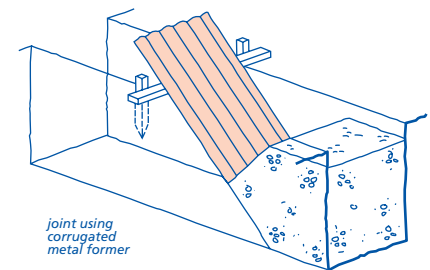

#### (b) stepping of foundations

Sloping ground may require stepped foundations.

Where foundations are stepped, the height of the step should not exceed the thickness of the foundation, unless it forms part of a foundation designed by an Engineer in accordance with Technical Requirement R5.

Foundation bottoms should be horizontal and steps, as near as possible, vertical.



## STRIP FOUNDATIONS

The overlap should be not less than:

- $2 \times S$ , or
  - $T$  (maximum 500mm), or
  - 300mm,
- whichever is the largest.

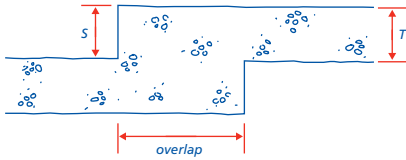

## TRENCH FILL FOUNDATIONS

The overlap should be not less than:

- $2 \times S$ , or
  - one metre,
- whichever is the larger.

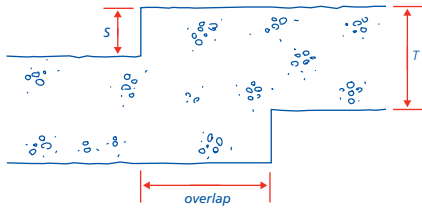

# 4.4 Strip and trench fill foundations

## Appendix 4.4-A

Approved Document A1/2, Section 2E, specifies the size of strip foundations using Diagram 24 and Table 10.

Also see Technical booklet D of Building Regulations (N Ireland) 1990.

Strip foundations should be:

- Located centrally under the wall
- of thickness  $P$  or 150mm (whichever is greater)
- of the width shown in Table 10.

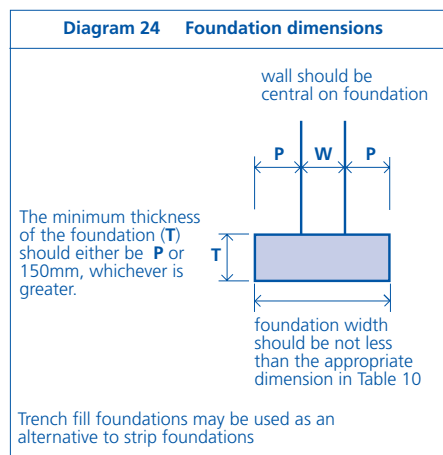

**Table 10 Minimum width of strip footings**

Type of ground (including engineered fill)	Condition of ground	Field test applicable	Total load of load-bearing walling not more than (kN/linear metre)					
			20	30	40	50	60	70
			Minimum width of strip foundation (mm)					
I Rock	Not inferior to sandstone, limestone or firm chalk	Requires at least a pneumatic or other mechanically operated pick for excavation	In each case equal to the width of the wall					
II Gravel or Sand	Medium Dense	Requires pick for excavation. Wooden peg 50mm square in cross section hard to drive beyond 150mm	250	300	400	500	600	650
III Clay Sandy clay	Stiff Stiff	Can be indented slightly by thumb	250	300	400	500	600	650
IV Clay Sandy clay	Firm Firm	Thumb makes impression easily	300	350	450	600	750	850
V Sand Silty sand Clayey sand	Loose Loose Loose	Can be excavated with a spade. Wooden peg 50mm square in cross section can be easily driven	400	600	Note Foundations on soil types V and VI do not fall within the provisions of this section if the total load exceeds 30 kN/m.			
VI Silt Clay Sandy clay Clay or silt	Soft Soft Soft Soft	Finger pushed in up to 10mm	450	650				
VII Silt Clay Sandy clay Clay or silt	Very soft Very soft Very soft Very soft	Finger easily pushed in up to 25mm	Refer to specialist advice					

This table is applicable only within the strict terms of the criteria described within it.

**INDEX**

<b>A</b>		<b>H</b>		<b>R</b>	
Adjoining constructions	1	Hazardous ground	1	Reinforcement	2, 4
<b>C</b>		<b>I</b>		<b>S</b>	
Compressible materials	2	Imposed loads	1	Services	2, 3
Concrete	2, 4	<b>J</b>		Setting out	3
<b>D</b>		Joints	4	Shrinkable clay	1, 3
Dead loads	1	<b>L</b>		Site conditions	1
Design standard	1	Loads	1	Sitework standards	2
Drainage	2, 3	<b>M</b>		Sleeper walls	1
<b>E</b>		Materials standards	2	Soft spots	4
Excavations	3	Movement joints	2	Stepped foundations	2, 4
<b>F</b>		<b>O</b>		Statutory requirements	1
Foundation depths	1	Overlap	5	<b>T</b>	
Foundation dimensions	6	<b>P</b>		Transmission of loads	1
Frost	2	Provision of information	2	Trench bottoms	3



# Chapter 4.5

Raft, pile, pier and beam foundations

---



# 4.5 Raft, pile, pier and beam foundations

## CONTENTS

	Clause	Page
<b>DESIGN</b>		
Design standards	D1	1
Statutory requirements and other standards	D2-D3	1
Hazardous ground	D4	1
Notification	D5	1
Supervision by an Engineer	D6	1
Requirement for foundations	D7	1
Site conditions	D8	1
Differential settlement	D9	1
Services, including drainage	D10	1
Movement joints	D11	1
Damp-proofing	D12	2
Safe transmission of loads	D13	2
Provision of information	D14-D15	2
<b>MATERIALS</b>		
Materials standards	M1	2
Concrete	M2	3
Reinforcement	M3	3
Other materials	M4-M5	3
<b>SITWORK</b>		
Sitework standards	S1	3
Setting out foundations	S2	3
Excavations	S3-S5	3
Services and drainage	S6-S7	4
Reinforcement	S8	4
Concreting	S9	4
Raft foundations	S10	4
Piled foundations	S11	4
Pier and beam foundations	S12	4
<b>APPENDIX 4.5-A</b>		
Guidance for the design of semi-raft foundations on made ground		4
<b>INDEX</b>		5

## SCOPE

This Chapter gives guidance on meeting the Technical Requirements and recommendations for raft, pile, pier and beam foundations.

## DESIGN STANDARDS

### 4.5 - D1 Design shall meet the Technical Requirements

Design that follows the guidance below will be acceptable for raft, pile, pier and beam foundations.

## STATUTORY REQUIREMENTS AND OTHER STANDARDS

### 4.5 - D2 Design shall comply with statutory requirements

Design should be in accordance with relevant Building Regulations and other statutory requirements.

### 4.5 - D3 Design shall follow relevant Standards and Codes of Practice

Relevant British Standards and Codes of Practice include:

BS 648	Schedule of weights of building materials
BS EN 1991	Actions on structures
BS EN 1992	Design of concrete structures
BS EN 1997-1	Geotechnical design: General rules
BS 10175	Investigation of potentially contaminated sites - Code of practice.

## HAZARDOUS GROUND

### 4.5 - D4 The design of foundations shall take account of the characteristics of the site, its ground and any hazards

Where there is hazardous ground, the foundation design must be carried out by an Engineer in accordance with Technical Requirement R5.

Details of ground hazards to be taken into consideration are given in Chapters: 4.1 'Land quality - managing ground conditions'

4.2 'Building near trees'

## NOTIFICATION

### 4.5 - D5 NHBC shall be notified before work starts on site

NHBC Rules state:

"If a Home is to be constructed on a Hazardous Site you must before making an Application for Inspection notify the NHBC in writing of the particular hazards which arise. You must do this at least 8 weeks before work begins on the site."

## SUPERVISION BY AN ENGINEER

### 4.5 - D6 When foundations have been designed by an Engineer, the Builder shall require the Engineer to visit the site during construction

The visits by the Engineer are necessary so that the Engineer can be satisfied that the design of the foundation is suitable for the actual ground conditions encountered and that the construction is in accordance with the design.

## REQUIREMENT FOR FOUNDATIONS

### 4.5 - D7 All masonry and all loadbearing elements shall be adequately supported by foundations

Elements requiring foundations include the following:

- external walls
- separating (party) walls
- chimney breasts
- piers
- internal loadbearing or masonry walls
- sleeper walls.

## SITE CONDITIONS

### 4.5 - D8 Foundations shall be designed to suit site conditions

Items to be taken into account include:

#### (a) site and ground appraisals

All information relating to the site and its ground conditions which is necessary for full and proper foundation design should be obtained.

#### (b) dwelling design

Foundation design should take account of the shape, size and construction of the dwellings as well as the site layout.

Foundations for terraced dwellings may require special precautions to prevent damage from differential settlement.

#### (c) site layout

Building over changes in ground characteristics should be avoided.

#### (d) site levels

Stepped foundations and suspended floor slabs may be needed for sloping sites.

#### (e) sulfate and acids in ground or groundwater

Sulfates and other chemicals can cause expansion and disruption of concrete. Also, high acidity, for example in peat, or permeable soil with acidic groundwater, can cause damage to concrete. Where concrete is at risk from chemical attack from the ground or where the groundwater is highly mobile, the level of sulfate and other chemicals should be determined,

in terms of the ACEC Class (Aggressive Chemical Environment for Concrete Class) in accordance with BRE Special Digest 1. Where sulfates or high acidity in ground or groundwater are present, reference should be made to Chapter 2.1 'Concrete and its reinforcement' (each section) for guidance concerning acceptable concrete mixes.

#### (f) trees

Where trees are nearby or are to be planted nearby (especially where the soil is shrinkable), foundations should be designed as shown in Chapter 4.2 'Building near trees'.

#### (g) frost susceptible soils

To avoid damage from frost action, the depth to the underside of the foundation in frost susceptible ground should be at least 450mm below finished ground level.

## DIFFERENTIAL SETTLEMENT

### 4.5 - D9 Foundations shall be designed to take account of differential settlement

Foundations should be designed to avoid any local stress points or any differential settlement. Foundations for attached bays, porches, garages, conservatories and other structures should be a continuation of those for the main dwelling, unless the design indicates an alternative which takes account of differential movement, for example separate foundations.

Foundations adjoining those of an existing building may require special precautions to limit differential movement.

## SERVICES, INCLUDING DRAINAGE

### 4.5 - D10 Foundation design shall take account of access for services

Where services are to pass through, or under, foundations provision should be made for suitable ducts or lintels to enable them to be installed later, in such a way as not to impair structural stability. For further details, reference should be made to the Design and Sitework sections of Chapters:

5.1 'Substructure and ground bearing floors'

5.3 'Drainage below ground'

8.1 'Internal services'.

## MOVEMENT JOINTS

### 4.5 - D11 Movement joints should be suitable for their intended purpose

Movement joints should be located so as to limit the risk of damage caused by movement. Suitable materials are given in the Materials section.

# 4.5 Raft, pile, pier and beam foundations

## DAMP-PROOFING

**4.5 - D12 The foundation design shall prevent the passage of moisture to the inside of the dwelling**

Items to be taken into account include:

**(a) a drained cavity**

Cavity walls should drain below dpc and prevent water flooding cavities above dpc levels or crossing from the outside to the inside. A clear cavity of 225mm minimum below dpc is required. Where foundations other than strip or trench fill are used, including those for timber framed dwellings, this may be reduced to 150mm minimum below dpc provided that weep holes and other measures, where necessary, are taken to ensure that the cavity can drain freely. Dpc cavity trays are not an acceptable weather-proofing to the edges of specialised foundations, such as rafts and ground beams.

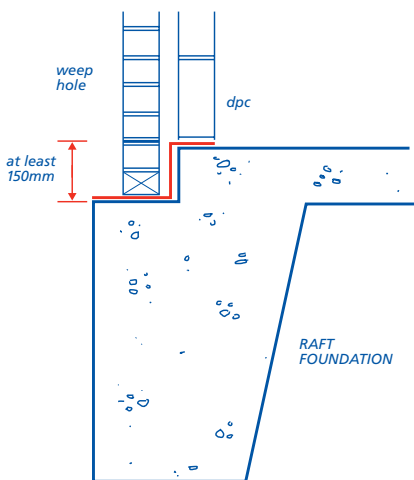
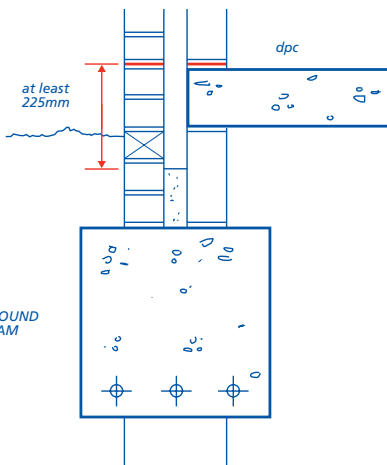

**(b) damp-proof membranes**

For the provision of damp-proof membranes, reference should be made to Chapters 5.1 'Substructure and ground bearing floors' (each section) and 5.2 'Suspended ground floors' (each section).

## SAFE TRANSMISSION OF LOADS

**4.5 - D13 Foundations shall transmit the loads from the structure to the supporting strata safely and without excessive settlement**

Items to be taken into account include:

- (a) need for adequate stiffness to ensure differential movement does not adversely affect the supported structure**
- (b) the nature and bearing capacity of the fill material to be placed under the foundation**
- (c) specification of concrete**
- (d) cover to reinforcement**

### RAFT FOUNDATIONS

Rafts and semi-rafts should:

- meet Clauses D1 to D12, where applicable
- prevent the erosion of ground beneath the raft
- be designed to accommodate, where required, warm air ducts, service ducts or services without any adverse effect upon performance of the foundation.

Where appropriate, precautions should be taken to limit the risk of ducts becoming flooded.

Semi-raft foundations on made ground should follow the guidance given in Appendix 4.5-A.

For details of suitable fill for raft foundations, refer to Chapter 5.1 'Substructure and ground bearing floors' Appendix 5.1-A.

### PILED FOUNDATIONS

Piled foundations should:

- meet Clauses D1 to D12, where applicable
- follow the guidance given in Sitework clause 4.5 - S11.

The design should specify precautions to be taken in cohesive soils where volume changes can occur.

The bearing capacity and integrity of piles should be confirmed by testing, when required.

### PIER/PAD AND BEAM FOUNDATIONS

Pier/pad and beam foundations should:

- meet Clauses D1 to D12, where applicable.

### VIBRATORY GROUND IMPROVEMENT TECHNIQUES

Vibratory ground improvement should:

- meet Clauses D1 to D12, where applicable
- comply with Chapter 4.6 'Vibratory ground improvement techniques'.

## PROVISION OF INFORMATION

**4.5 - D14 Drawings and specifications should be produced in a clearly understandable format**

All relevant information needed for the completion of the sitework should be stated clearly and unambiguously and be readily available to all concerned.

All necessary dimensions and levels should be indicated and related to:

- at least one bench mark, and
- reference points on site.

**4.5 - D15 Designs and specifications, together with relevant site information, shall be distributed to appropriate personnel**

Details should be provided with respect to:

- dimensions, type and depth of foundations
- junctions
- steps
- movement and construction joints
- detailing of ducts
- location of services
- critical sequences of construction.

Designers need to be aware of the ground conditions and, in particular, any features requiring special attention, such as any existing sewers or other services, levels of water table and the presence of any deleterious substances, especially sulfates.

Where toxic materials (or materials likely to present a health hazard) are found, all available information should be supplied to NHBC, together with proposals for dealing with the hazard.

## MATERIALS STANDARDS

**4.5 - M1 All materials shall:**

- (a) meet the Technical Requirements**
- (b) take account of the design**

Materials that comply with the design and the guidance below will be acceptable for raft, pile, pier and beam foundations.

Materials for raft, pile, pier and beam foundations should comply with all relevant standards, including those listed below. Where no standard exists, Technical Requirement R3 applies (see Chapter 1.1 'Introduction to the Standards and Technical Requirements').

References to British Standards and Codes of Practice include those made under the Construction Products Directive (89/106/EEC) and, in particular, appropriate European Technical Specifications approved by a European Committee for Standardisation (CEN).



## CONCRETE

**4.5 - M2 Concrete shall be of a mix design which will achieve the required strength and be sufficiently resistant to chemical and frost action**

For guidance on the specification and use of concrete, particularly in relation to the choice of mix to achieve sufficient structural strength and resist deterioration due to ground aggressivity and frost action, reference should be made to Chapter 2.1 'Concrete and its reinforcement' (each section).

## REINFORCEMENT

**4.5 - M3 Reinforcement shall be sufficient to ensure proper transfer of loads**

Reinforcement shall be in accordance with Chapter 2.1 'Concrete and its reinforcement' (each section).

## OTHER MATERIALS

**4.5 - M4 Compressible materials shall be capable of absorbing potential heave forces, where appropriate**

Proprietary materials should be either assessed in accordance with Technical Requirement R3 or acceptable to NHBC through established custom and practice.

**4.5 - M5 Sealing materials for movement joints shall be suitable for their intended purpose**

Joints often fail because the likely variation in the size of the joint is not compatible with the movement capability of the sealing material.

Factors to be taken into account when choosing materials for movement joints should include:

- designed joint width
- actual joint width
- joint depth
- anticipated movement
- movement capability of seal
- surface preparation
- backing medium
- projected life span of joint.

Sealants should be such that there is good adhesion between the sealant and the material either side of the joint.

Back up material should be resilient and should not adhere to, or react with, the sealant.

The compressibility of the sealant back-up/joint filler is possibly the most critical factor in the design of an adequate joint for fired clay brickwork.

A pressure of about 0.1N/mm<sup>2</sup> should be sufficient to compress the material to 50% of its original thickness. Flexible cellular polyethylene, cellular polyurethane or

foam rubbers are the most satisfactory materials for backing to movement joints in fired clay brickwork.

Hemp, fibreboard, cork and similar materials are suitable for movement joints in concrete, but should not be used for expansion joints in fired clay brickwork.

## SITWORK STANDARDS

**4.5 - S1 All sitework shall:**

- meet the Technical Requirements
- take account of the design
- follow established good practice and workmanship

Sitework that follows the design and the guidance below will be acceptable for raft, pile, pier and beam foundations.

## SETTING OUT FOUNDATIONS

**4.5 - S2 The setting out of foundations shall take account of the design details**

The accuracy of setting out should be checked by control measurements of trenches, including their location relative to site boundaries and adjacent buildings. Levels should be checked against bench marks, where appropriate.

In particular, for excavations check:

- trench lengths
- trench widths
- length of diagonals between external corners.

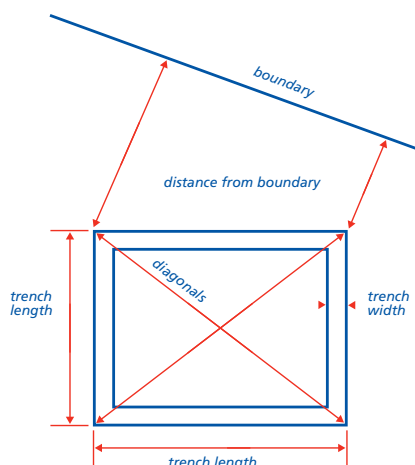

In addition, for piles, pier and beam foundations and ground improvement techniques, check:

- spacing
- alignment
- positions in relation to the proposed superstructure.

Walls should be located centrally on the foundation, unless specifically designed to do otherwise.

Any discrepancy in dimensions, and any ground condition that causes the design to

be modified, should be reported formally to the Engineer. Resulting variations should be recorded and distributed to all concerned (including NHBC).

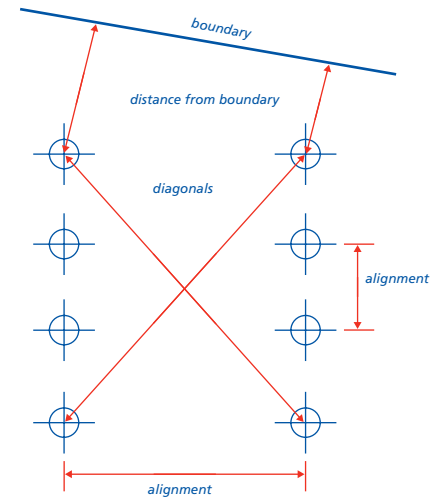

## EXCAVATIONS

**4.5 - S3 Excavations for foundations shall take account of design dimensions**

Excess excavations should be avoided. Inaccuracy may prevent walls and piers being located centrally and therefore result in eccentric loading of foundations, possibly foundation failure.

To avoid damage, foundation excavation should be kept free from water (see Clause S5).

**4.5 - S4 Excavations shall take account of localised effects**

Where localised changes in strata give rise to differences in bearing capacity, reference should be made to the Engineer to ensure this has been allowed for in the design.

At soft spots, excavations should be deepened locally to a sound bottom or, alternatively, the concrete should be reinforced.

Hard spots should be removed.

Where roots are visible on the sides or bottoms of excavations (especially in clay soils), the Engineer should be consulted and the design depth modified.

Where there are, or have been, trees or hedges, foundation depth should be in accordance with the guidance given in Chapter 4.2 'Building near trees'.

**4.5 - S5 Excavation bottoms, when prepared for concreting, shall be compact, reasonably dry and even**

Trench bottoms affected by rainwater, ground water or drying should be re-bottomed to form a sound surface.

# 4.5 Raft, pile, pier and beam foundations

## SERVICES AND DRAINAGE

### 4.5 - S6 Existing services shall be adequately protected

Any existing services, such as cables, water pipes or gas mains, may need to be supported and protected. Any existing drains should be diverted, or bridged, to prevent any foundation loads being transmitted to them.

Services should not be rigidly encased in concrete, masonry, etc.

Land drains should be diverted to a suitable outfall.

### 4.5 - S7 Provision shall be made for service entries or services

For relevant details, reference should be made to the Design and Sitework sections of Chapters:

5.1 'Substructure and ground bearing floors',

5.3 'Drainage below ground'

8.1 'Internal services'

Where services pass through foundations, they must not affect the ability of the foundation to carry loads.

Services should be either sleeved or passed through a suitably strengthened opening in the foundation.

In the case of drains, it is important to leave sufficient space for movement, to ensure that the drain is capable of maintaining line and gradient and any movement which may take place.

## REINFORCEMENT

### 4.5 - S8 Reinforcement shall be cut, bent and placed as shown in the design

Reinforcement shall be clean and free from loose rust and should be placed correctly. Bars should be properly supported to ensure that the cover indicated in the design is maintained.

Bars should be secured at laps and crossings.

## CONCRETING

### 4.5 - S9 Concrete shall be correctly mixed, placed and cured

Concreting should be carried out, as far as possible, in one operation, taking account of weather conditions and available daylight. Concrete should be placed as soon as possible after the excavation or, where necessary, after the reinforcement has been checked. Excavation and/or reinforcement may need to be approved by the Engineer or his representative, before concreting commences. In England and Wales, foundations should be approved

by the person responsible for the Building Control inspections, before the concrete is placed.

Mixing, placing, testing and curing of concrete should be carried out as indicated in Chapter 2.1 'Concrete and its reinforcement' (each section) and when work is carried out in cold weather, Chapter 1.4 'Cold weather working'.

## RAFT FOUNDATIONS

### 4.5 - S10 Raft and semi-raft foundations shall be constructed in accordance with the design

Raft and semi-raft foundations should be constructed in accordance with Clauses S1 to S9, as appropriate.

## PILED FOUNDATIONS

### 4.5 - S11 Piled foundations shall be constructed in accordance with the design

Items to be taken into account include:

#### (a) alignment

Piles are to be vertical, unless designed otherwise.

Piles are to be installed by an appropriate specialist under the Engineer's supervision.

#### (b) load capacity verification

Care should be taken to ensure that the bond of beams to pads and piles is in accordance with the design and is adequate.

Test loading should be undertaken when required.

The Builder is to obtain written confirmation that the piles are suitable for their design load.

If piles are more than 75mm out of position, or out of alignment by more than 1 : 75, the Engineer should reconsider the adequacy of the foundation design.

Unless otherwise recommended by the Engineer, NHBC will expect piles which are misaligned by more than 150mm in any direction, or which are more than 5° from their specified rake, to be replaced, or additional piles to be provided in accordance with design modifications provided by the Engineer.

## PIER AND BEAM FOUNDATIONS

### 4.5 - S12 Pier and beam foundations shall be constructed in accordance with the design

Pier/pad and beam (and reinforced concrete strip) foundations should be constructed to meet Clauses S1 to S9, as appropriate.

## Appendix 4.5-A

### Guidance for the design of semi-raft foundations on made ground

The following notes are to be used as a guide for Engineers designing raft foundations, but are by no means exhaustive. Special consideration will be required for certain sites.

- 1 Raft foundations are to be designed by a Chartered Civil or Structural Engineer taking account of ground conditions and the results of the site appraisal and ground assessment.
- 2 Sufficient internal beams are to be provided to adequately stiffen the slab.
- 3 The area between downstand beams should not be greater than 35m<sup>2</sup>.
- 4 The ratio of adjacent sides on plan should not exceed 2 : 1.
- 5 The minimum depth of perimeter and party wall beams is to be 450mm. On larger dwellings some internal beams should be of the same depth as the perimeter beams.
- 6 Perimeter and internal beams should be sufficiently wide at their base to carry their total loading at the allowable bearing pressure for the site.
- 7 Beams are to be designed to span 3m simply supported and cantilever 1.5m.
- 8 Beams are to use properly formed reinforcement in accordance with BS EN 1992-1-1
- 9 Where mesh is used in beams, it should be delivered to the site pre-bent.
- 10 All beams should be cast on a minimum of 50mm concrete blinding.
- 11 Minimum cover to reinforcement should be 40mm.
- 12 Floor slabs should be a minimum 150mm thick, with nominal top face reinforcement as a minimum and anti-crack reinforcement in the bottom face, if appropriate.
- 13 Stools or similar should be used to support floor slab mesh during casting.
- 14 Corners and junctions to beams should be adequately tied using similar reinforcement to the beams.
- 15 A minimum cavity drain of 225mm below dpc is to be maintained.

## INDEX

<b>A</b>		<b>L</b>		<b>S</b>	
Alignment	4	Levels	1	Sealing materials	3
<b>C</b>		Loads	2, 4	Services	1, 4
Cavity walls	2	<b>M</b>		Setting out	3
Compatible materials	2	Made ground	4	Settlement	1
Concrete	3, 4	Materials standards	2	Site conditions	1
<b>D</b>		Movement joints	1, 3	Sitework standards	3
Damp proofing	2	<b>N</b>		Statutory requirements	1
Design standards	1	Notification	1	Sulfates	1
Drainage	1, 4	<b>P</b>		Supervision	1
Dwelling design	1	Pier/pad and beam foundations	2, 4	<b>T</b>	
<b>E</b>		Piled foundations	2, 4	Trees	1
Excavations	3	Provision of information	2	Trench bottoms	3
<b>F</b>		<b>R</b>		<b>V</b>	
Frost	1	Raft foundations	2, 4	Vibratory techniques	2
<b>H</b>		Reinforcement	3		
Hazardous ground	1				



# Chapter 4.6

## Vibratory ground improvement techniques

---



# 4.6 Vibratory ground improvement techniques

## CONTENTS

	Clause	Page
<b>DESIGN</b>		
Design standards	D1	1
Statutory requirements and other standards	D2-D3	1
Hazardous ground	D4	1
Notification	D5	1
Desk Study & Site investigation	D6	1
Suitability of ground conditions	D7	1
Confirmation of suitability of proposed treatment	D8	2
Compatibility of layout and design for the treated ground	D9	2
<b>MATERIALS</b>		
Materials standards	M1	4
Stone fill	M2	4
Granular material	M3	4
<b>SITWORK</b>		
Sitework standards	S1	4
Site supervision	S2	4
Verification of completed treatment	S3-S4	4-5
<b>APPENDIX 4.6-A</b>		
Soil classification chart		6
Vibratory techniques		7
<b>APPENDIX 4.6-B</b>		
Materials for use as fill		8
<b>INDEX</b>		8

## SCOPE

This Chapter gives guidance on meeting the Technical Requirements and recommendations for vibratory ground improvement techniques.

**DESIGN STANDARDS**

**4.6 - D1 Design shall meet the Technical Requirements**

Design that follows the guidance below will be acceptable for foundations on ground improved by vibratory techniques.

**STATUTORY REQUIREMENTS AND OTHER STANDARDS**

**4.6 - D2 Design shall comply with statutory requirements**

Design should be in accordance with relevant Building Regulations and other statutory requirements.

**4.6 - D3 Design shall follow relevant Standards and Codes of Practice**

Relevant British Standards, Codes of Practice and authoritative documents include:

BS 10175	Investigation of potentially contaminated sites - Code of practice
BS EN 1991	Actions on structures
BS EN 14731	Execution of special geotechnical works. Ground treatment by deep vibration
BS EN 1997-1	General rules
BS EN 1997-2	Ground investigation and testing
BS EN ISO 14688	Geotechnical investigation and testing- Identification and classification of soil
BS EN ISO 14689	Geotechnical investigation and testing- Identification and classification of rock
BS EN ISO 22476	Geotechnical investigation and testing- Field testing
BR 391	Specifying vibro stone columns
ICE Specification for Ground Treatment	

**HAZARDOUS GROUND**

**4.6 - D4 The design of foundations shall be undertaken by an Engineer and take account of the characteristics of the site, its ground and any hazards**

The foundation design should be carried out by an Engineer experienced with ground improvement techniques in accordance with Technical Requirement R5 - see Chapter 1.1.

In this Chapter, the term "Engineer" means an engineer who is independent of the

specialist contractor responsible for the vibratory ground improvement techniques.

Details of ground hazards to be taken into consideration are given in Chapters:

- 4.1 'Land quality - managing ground conditions'
- 4.2 'Building near trees'

**NOTIFICATION**

**4.6 - D5 NHBC shall be notified before work starts on site**

NHBC Rules state: "If a Home is to be constructed on a Hazardous Site you (the Builder) must before making Application for Inspection notify the NHBC in writing of the particular hazards which arise. You (the Builder) must do this at least 8 weeks before work begins on the site." Early involvement of the specialist contractor and NHBC is encouraged.

**DESK STUDY AND SITE INVESTIGATION**

**4.6 - D6 The Engineer shall ensure that a desk study and site investigation are commissioned and the interested parties are advised**

The site investigation should take account of:

BS 10175	Investigation of potentially contaminated sites - Code of practice
BS EN14731	Execution of special geotechnical works. Ground treatment by deep vibration
BS EN1997-2	Ground investigation and testing
BS ENISO 14688	Geotechnical investigation and testing- Identification and classification of soil
BS ENISO 14689	Geotechnical investigation and testing- Identification and classification of rock
BS EN ISO 22476	Geotechnical investigation and testing- Field testing
BR391	Specifying vibro stone columns

Chapter 4.1 'Land quality - managing ground conditions'

The desk study and site investigation should at least determine:

- the depths and properties of the natural materials under the site, including the presence of caves, workings, or natural phenomena such as rocks or soils which dissolve or erode when exposed to the passage of water. The Engineer should establish the scope of, and supervise, the site investigation, taking account of the findings of the desk study. Data

for comparison with post treatment properties should be established

- the extent and nature of any areas of filled ground on the site, including:
  - the proportions and distribution of constituent materials
  - the state of compaction of the fill material throughout its depth
  - the grading and particle size distribution of fill materials
  - the potential for gas generation from fill materials
  - the potential for spontaneous combustion of fill and/or natural deposits
- the presence and extent of any existing or redundant services and drains, and what information is available regarding the extent and nature of the backfill to the excavations
- the effect that any sustainable drainage system (SUDS) may have on the geotechnical parameters of the site
- the presence, level and nature of any ground water, and if it is likely to rise and cause heave or collapse by saturation
- whether the site has been previously occupied by any structure, and whether these structures have left any potential underground obstructions or hardspots, eg basement walls, floor slabs etc
- whether there are any contaminated substances or gases present or suspected.

The Specialist Contractor should be satisfied that the site investigation provides adequate and representative information in order to design the ground improvements. The results of the investigation should be sent to NHBC prior to the commencement of the work.

**SUITABILITY OF GROUND CONDITIONS**

**4.6 - D7 The ground shall be suitable for vibratory ground improvement**

The Engineer should assess the ground and be satisfied that it is suitable for treatment. Vibratory ground improvement techniques suitable for various ground conditions are detailed in Appendix 4.6-A.

Items to be taken into account include:

**(a) ground conditions acceptable for treatment**

Conditions acceptable for treatment are only those within zones A and B of the chart shown in Appendix 4.6-A.

**(b) ground conditions not generally acceptable for treatment**

The following ground conditions are not generally acceptable for treatment:

# 4.6 Vibratory ground improvement techniques

4.6

- soft clays with an undrained shear strength less than 30kN/m<sup>2</sup> (Note; for clay strengths less than 30kN/m<sup>2</sup> additional consideration has to be given to group effects, ground heave and settlement due to installation and the proposal will be subject to NHBC agreement)
- ground with peat layers close to foundation level or the base of the stone column, or where intermediate layers of peat are thicker than 200mm either as a single layer or the sum of the thicknesses of individual layers throughout the length of the stone column
- voided filled ground, eg old water tanks, pottery, glass bottles, concrete rubble or brick fill of unsuitable grading
- any loose or non-engineered fill not previously subject to:
  - rising or fluctuating water levels
  - saturation
- filled ground still settling or expected to settle:
  - under its own weight or due to the effects of surcharging/upfilling
  - where there is a high organic content
  - where decay is continuing



- fill, containing degradable material where organic material forms more than 15% of fill by volume
- highly contaminated ground, eg toxic waste, or where inflammable, explosive or toxic gas generation will take place (stone columns may act as vertical vents). Note: Consideration will be given to proprietary systems which do not permit vertical venting (e.g. vibro concrete plug technology)

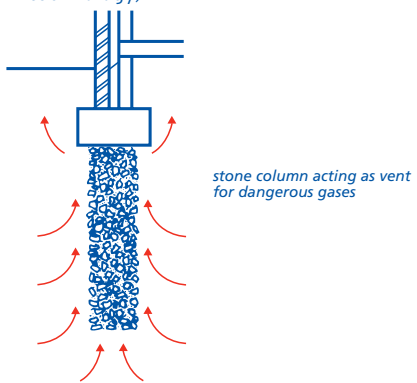

- clays with a plasticity index greater than 40%
- highly sensitive soils liable to collapse or remoulding

### (c) detrimental factors

Factors to be considered include the following:

- where partial depth treatment of filled ground is proposed, the Engineer

should be satisfied as to the anticipated performance of both the treated and untreated zones. The Specialist Contractor should take responsibility for the treated zone and the decision as to the depth of treatment

- the minimum depth of soil treated should allow for the interaction of adjacent foundations

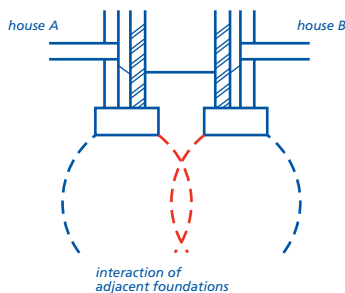

- stone columns may form vertical drains allowing the passage of water to a moisture susceptible strata, or provide seepage paths for gases

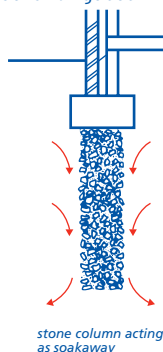

- obstructions and variations in the density of fill and natural ground (hard spots)
- alterations to the oversite level before or after treatment or disturbance of ground by excavations after treatment
- the location of changes in the profile of the natural underlying ground eg edges of pits or quarries, slopes, or manmade obstructions such as soakaways or drainage runs
- long term lowering of water table causing settlement of existing adjacent buildings

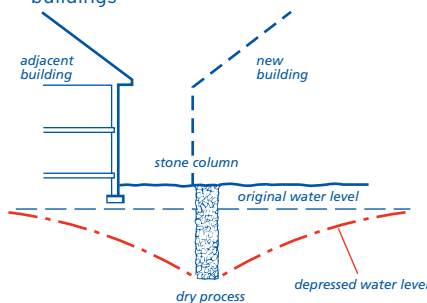

- short term rise in local water table due to large volumes of water used in wet process during construction causing settlement or heave of existing adjacent buildings

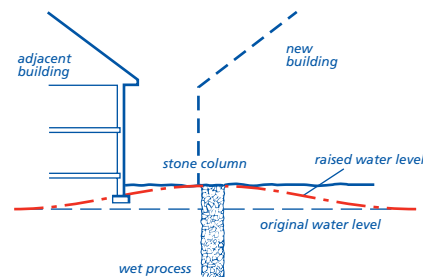

- surface water sewers should be used for rainwater disposal where possible, but where soakaways are necessary, these should be positioned so that their construction and operation is not detrimental to the treated ground
- the effect of any new or existing sustainable drainage systems (SUDS) should be taken into account when vibro improvement techniques are proposed
- soils with a modified Plasticity Index of 10% or greater should have foundations designed to accommodate volume changes, and the depth of concrete foundation should be in accordance with Chapter 4.2 'Building near trees'.

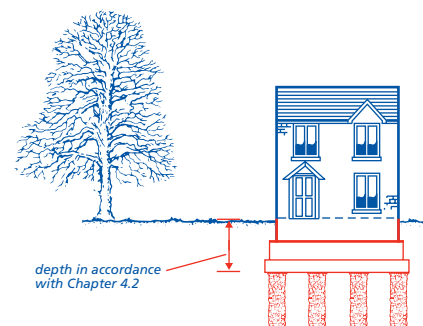

## CONFIRMATION OF SUITABILITY OF PROPOSED TREATMENT

**4.6 - D8 The builder shall obtain written confirmation from the Engineer and Specialist Contractor that the site is suitable for the proposed ground improvement system**

Confirmation that the site is suitable for the proposed system should be made available to NHBC prior to commencement of the work.

The Engineer and Specialist Contractor should agree the following in writing before work commences on site:

- design objectives
- a detailed schedule of work
- a programme of work
- what tests are to be carried out on completion of the work
- responsibility for procedures and tests.

For details of tests see Sitework clause S3.

The following should also be taken into account:



- the layout and depth of the stone columns and the accuracy to be achieved (see Sitework clause S2)
- what factors of safety have been incorporated into the design to allow for unforeseen contingencies
- the criteria for non acceptance of the vibrating poker work
- what calculations and case histories are required to justify the ground improvement proposals together with the layout of the stone columns and details of the equipment and process to be used on site.

These written agreements should be made available to NHBC before work commences on site.

## COMPATIBILITY OF LAYOUT AND DESIGN FOR THE TREATED GROUND

### 4.6 - D9 Design shall ensure that site layout and dwelling design are compatible with the treated ground

Items to be taken into account include:

#### (a) limitations of the treated ground

The Engineer should:

- undertake discussion with the Specialist Contractor to confirm the feasibility of proposals
- determine the loads to be imposed by the buildings and assess against the results of the site investigation
- confirm the required load/settlement performance of the treated ground

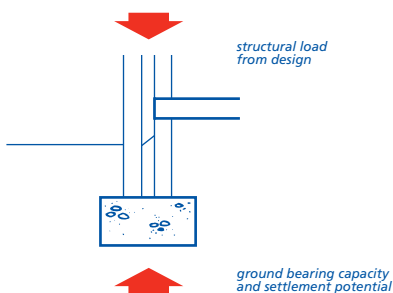

- consider limitations of the configuration of the dwellings:
  - T-block and L-block vulnerable at junctions
  - vulnerability of long blocks
- avoid siting buildings in locations where major changes in ground conditions can be expected

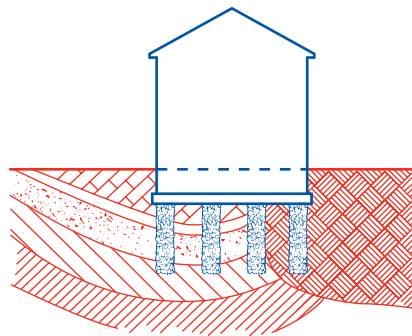

- advise and discuss design criteria with NHBC at the design stage.

#### (b) limitations of ground support

The Engineer should:

- establish the likely limits of ground movement
- allow for ground movement in the design, including where appropriate:
  - position and spacing of movement joints
  - flexibility of masonry mortars
  - masonry reinforcement.



#### (c) drainage and service trenches

The Engineer should consider the influence of drainage and other service trenches on the stability of the complete design (see Sitework clause S4).

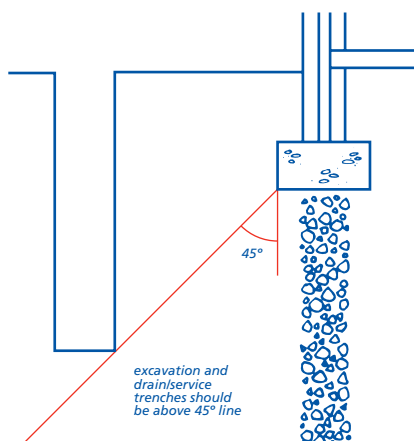

#### (d) suitable foundation types

The following criteria should be incorporated in the foundation design to ensure the compatibility and overall stability of the foundations and superstructure:

- only two types of foundations are suitable, both of which should comply with the minimum criteria for areas of reinforcement as defined in BS EN 1992-1-1. They are:
  - reinforced concrete strip foundation

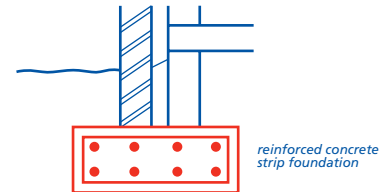

- reinforced concrete raft or semi-raft foundation positioned on a uniformly compacted bed of hardcore

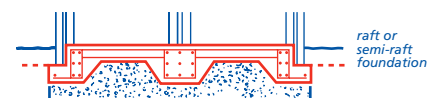

- for both types of foundation, top and bottom reinforcement should be provided
- the depth of foundations to be a minimum of 600mm below the surface of the treated ground, and founded on firm material of adequate bearing capacity
- where the treated ground is of a granular nature, a reinforced concrete strip foundation will normally be acceptable provided that the full depth of all fill material is treated
- if the treated ground is of a cohesive nature, a suitably designed raft, semi-raft or reinforced concrete strip foundation will normally be acceptable
- the reinforced concrete foundation should be designed to span between the centres of adjacent stone columns unless a more rigorous structural analysis is carried out to show that an alternative detail is acceptable
- if partial depth treatment of filled ground is proposed then a suitably designed reinforced concrete raft or semi-raft foundation should be used
- if during excavations for foundations in treated ground it is found that excessive depths of concrete are required, then precautions should be taken to ensure overall stability of the foundations, and the Engineer should be satisfied that construction of the foundation will not be detrimental to the treated ground.

# 4.6 Vibratory ground improvement techniques

## (e) use of suspended ground floors

Suspended ground floors should be provided for all dwellings where vibratory ground improvement has been carried out unless the Engineer can substantiate an alternative solution that is acceptable to NHBC.

## (f) notice to NHBC

Notice of the proposed development should be forwarded to NHBC.

Inform NHBC of the appointment of the Specialist Contractor and of the anticipated commencement date for treatment.

## MATERIALS STANDARDS

### 4.6 - M1 All materials shall:

- (a) meet the Technical Requirements
- (b) take account of the design

Materials that comply with the design and the guidance below will be acceptable for use in conjunction with vibratory ground improvement techniques.

Materials for use in conjunction with vibratory ground improvement techniques shall comply with all relevant standards, including those listed below. Where no standard exists, Technical Requirement R3 applies (see Chapter 1.1 'Introduction to the Standards and Technical Requirements').

References to British Standards and Codes of Practice include those made under the Construction Products Directive (89/106/EEC) and, in particular, appropriate European Technical Specifications approved by a European Committee for Standardisation (CEN).

## STONE FILL

### 4.6 - M2 Stone fill for forming columns shall be compatible with the ground conditions, and be suitable for the vibratory ground improvement process

Column fill should be clean, hard, inert material complying with the guidance given in Appendix 4.6-B.

In acidic ground conditions, limestone fill may not be acceptable.

The use of recycled aggregates should comply with the guidance in Appendix 4.6-B.

## GRANULAR MATERIAL

### 4.6 - M3 Granular material for raising site levels before treatment or adding during deep compaction shall:

- (a) be free from hazardous materials unless appropriate precautions are taken, and
- (b) be suitable for compaction

The appropriate precautions to be taken where hazardous materials are present in fill are detailed in Appendix 4.6-B.

The test requirements for fill given in Appendix 4.6-B should be followed where appropriate.

Well graded, inert fill which passes a 100mm x 100mm screen in all directions and contains less than 10% fine material of silt or clay size will normally be acceptable for raising site levels.

The grading of material for adding during deep compaction should be within Zone A of the chart shown in Design clause D7 and Appendix 4.6-A.

## SITWORK STANDARDS

### 4.6 - S1 All sitework shall:

- (a) meet the Technical Requirements
- (b) take account of the design
- (c) follow established good practice and workmanship

Sitework that complies with the design and the guidance below will be acceptable for vibratory ground improvement.

## SITE SUPERVISION

### 4.6 - S2 The Builder shall ensure that the Engineer visits the site and provides competent supervision throughout the ground treatment process

The Engineer should provide competent site supervision at critical stages (e.g:

- inspection of setting out and materials
- column installations during early stage of the work
- where installation data differ from design assumptions
- if changes in treatment layout are required)

throughout the period of the ground treatment process.

Some aspects of sitework may be the responsibility of the Engineer or his representative, or of the Specialist Contractor, rather than of the Builder.

Items to be taken into account include:

- (a) location, depth and alignment of columns

Supervision should be provided to ensure that:

- the minimum required depth of the stone columns is achieved, and they are correctly located. The Builder should provide sufficient profiles to enable locations to be checked
- the stone columns are located either centrally under the foundations they are to support or in the predetermined staggered arrangement, at a maximum of 2 metres centre to centre and at the intersection of adjacent reinforced concrete strips

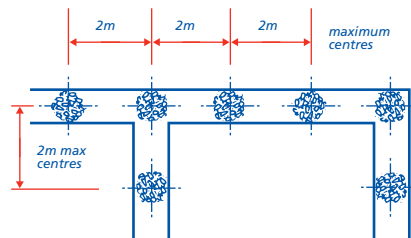

- missing stone columns are replaced
- stone columns which are misaligned by more than 150mm in any direction are replaced

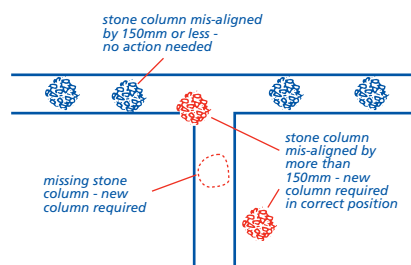

- a check on the location of all stone columns is made by the Engineer's representative prior to the specialist plant leaving the site.

### (b) unforeseen circumstances

Allowance should be made for:

- unforeseen changes in the site conditions, or trends which may affect site conditions. Changes should be recorded and reported to the Engineer immediately they become apparent
- changes in the anticipated depth of the compaction point in excess of 25% should be recorded and reported to the Engineer and Specialist Contractor as soon as possible but no later than the end of the day on which they occur
- variations of over 50% in the quantity of backfill used in compaction points of the same length. Variations should be recorded and reported to the Engineer and Specialist Contractor at the end of the day on which they occur
- unforeseen obstructions requiring either local removal and backfilling prior to treatment, or realignment of, and additional columns, coupled with local amendment of foundation design
- the effects of any of the above on the final efficiency of the treatment. These are to be fully considered by the

Engineer and the Specialist Contractor. The Builder and NHBC are to be advised immediately about proposed remedial measures.

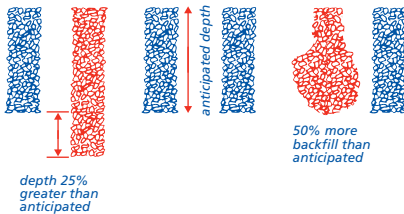

## VERIFICATION OF COMPLETED TREATMENT

### 4.6 - S3 The Engineer shall require the Specialist Contractor to verify that the ground treatment is satisfactory

Items to be taken into account include:

#### (a) suitable testing

Tests should be carried out to establish the degree of ground improvement, its load-bearing characteristics and settlement potential.

The types of test that can be used are described in the following clauses. The Specialist Contractor should predict the results from his experience of work on the type of ground, prior to the test taking place. Prediction of the results and the degree of tolerance within those results is to be agreed with the Engineer prior to testing, and compared with the test results.

If for example a threefold improvement were predicted and only a twofold improvement achieved, this could mean that the ground was different to that indicated by the investigation, or that the treatment carried out differed from the specified treatment. In such a case, further investigation would be necessary.

Tests on ground containing clay soils may need to be delayed for a few days after the completion of treatment to allow excess pore pressures to dissipate.

The Engineer may choose any appropriate combination of the following tests with the agreement of NHBC:

- 600mm diameter plate tests
- dummy footing/mini zone test
- zone test
- in situ test
- trial pits

#### 600MM DIAMETER PLATE TESTS

This test will not determine the design but will allow for an assessment to be made of the workmanship on the stone columns. Plate tests should be carried out on stone columns or treated ground at a frequency of at least one test per day per rig.

#### DUMMY FOOTING TEST/MINI ZONE TEST

A mini zone test can be used as a limited substitute for zone tests. The test should be applied to at least two stone columns and the area of foundation which they support. The load may be applied through a rigid beam or stiffened plate using skips or other known loads arranged to give a uniform distribution of the load.

To be useful, mini zone tests should be continued for sufficient time for creep behaviour to be quantified and allowances for this time should be made in the overall project programme.

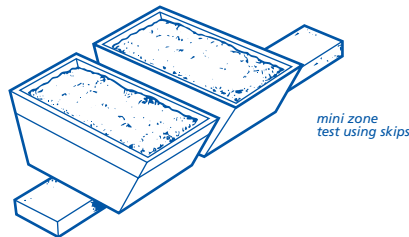

#### ZONE TEST

An isolated pad or strip footing is used, and up to 8 stone columns and the intervening ground can be tested. Loadings, which should simulate the dwelling loads, are held for 24 hours at pre-determined stages to examine creep behaviour.

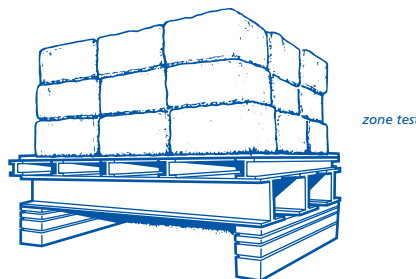

#### IN-SITU TEST

Where vibration will improve the ground itself, eg granular materials, then in-situ testing is appropriate. The improvement can be assessed when the test results are compared with the in-situ test results recorded during the pre-treatment investigation.

#### TRIAL PITS

Trial pits can be excavated around trial stone columns to prove that they are fully formed and to the required depth and diameter. This is a destructive test and allowance should be made accordingly.

#### (b) written confirmation of completed treatment

On completion of the treatment the Engineer should:

- from the results of the tests carried out satisfy himself that the treated ground has achieved the anticipated condition assumed in his design
- once satisfied with the effectiveness of the treatment in relation to the design, advise the Builder and NHBC accordingly in writing
- advise the Builder of any special precautions which should be taken for the positioning of services both beneath the dwelling and adjacent to it.

#### (c) record of the work

A comprehensive record of all works including information concerning the treatment, depth of fill, volume of stone used, on-site changes and all other relevant information, should be made available to NHBC.

#### 4.6 - S4 The Builder shall ensure that treated ground is not disturbed by subsequent excavations

Ensure that the minimum clearance between excavations and foundations is not less than the depth of excavation minus the depth of the structural foundation.

Particular attention is needed for excavation below the water table.

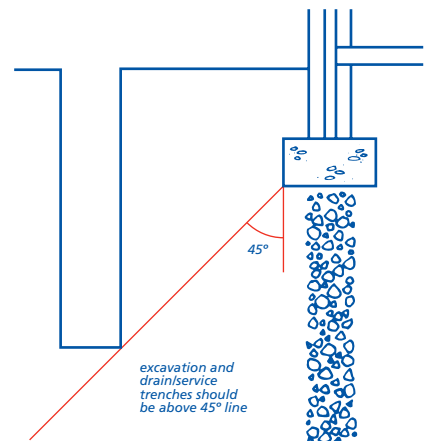

# 4.6 Vibratory ground improvement techniques

## APPENDIX 4.6-A

### SOIL CLASSIFICATION CHART

Conditions acceptable for treatment are only those within zones A and B of the chart.

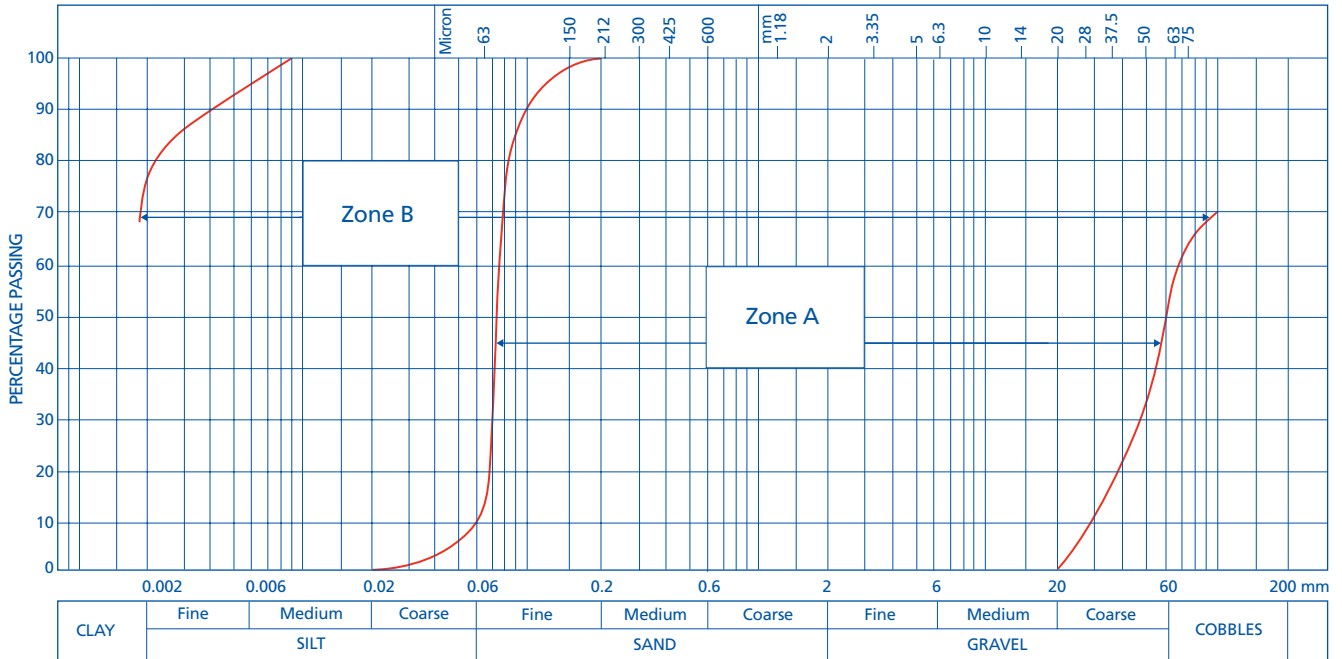

- Zone A Range of materials suitable for deep compaction (vibro-compaction) techniques
- Zone B Range of materials suitable for stone column (vibro-replacement) techniques

4.6

## Vibratory techniques

The vibratory process is applied usually to weak natural soils and filled ground. The purpose is to improve the load bearing capacity, reduce settlement and provide an adequate bearing stratum for the foundation supporting the dwelling.

A decision to buy a hazardous site is an acceptance by the builder/developer of the risks involved. It is important that the ground hazards are assessed before buying the site, and that allowance is made in foundation design for any consequences of this assessment.

Hazardous sites are defined in NHBC Rules.

### ACCEPTABLE METHODS

There are two vibratory techniques commonly used in the UK. These are known as the 'dry bottom feed' and 'dry top feed' methods, and are illustrated. A third technique, infrequently used in the UK, and known as the 'wet bottom feed' method is also acceptable to NHBC. This method is not illustrated.

#### Dry bottom feed method

In weaker soils or situations where there is a high water table and the bore hole is liable to collapse between vibrator insertions, the dry bottom feed method is adopted. The vibrator penetrates by its mass, air flush and vibration, but at design depth the stone is introduced via a hopper into a pipe fixed to the side of a vibrator. The stone, usually of 40mm size, exits the pipe at the tip of the vibrator and in to the bottom of the bore hole. The stone is then compacted into the surrounding soil by repeated withdrawal and insertion of the vibrator.

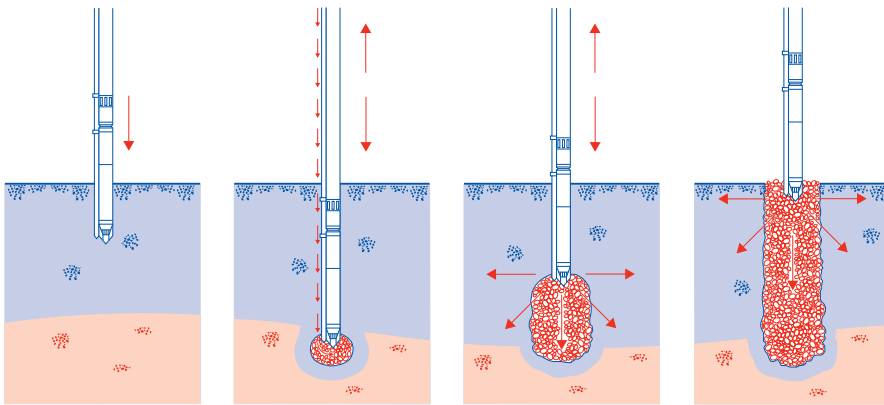

#### Dry top feed method

In the dry top feed method the vibrator penetrates the weak soil or fill by its mass, air flush and vibration to form a bore hole. Once refusal or design depth is reached the vibrator is removed and stone fill introduced into the bore, the 'charge' is typically 500-800mm deep. The vibrator is re-inserted and 'packs' the stone into the surrounding strata. Successive charges of stone are added and compacted bringing the column up to working level. Typically the stone grading is 40-75mm.

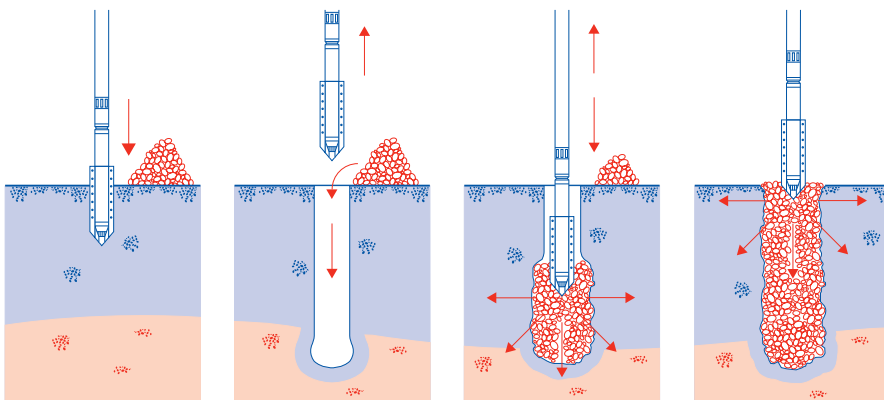

# 4.6 Vibratory ground improvement techniques

## Appendix 4.6-B

### MATERIALS FOR USE AS FILL

#### Hazardous materials

The following materials require testing to ensure their suitability for use as fill to support structural foundations and slabs or as backfill to associated trenches:

- acid wastes
- reactive materials
- materials that include sulfates (eg gypsum)
- organic materials
- toxic materials
- materials that cause noxious fumes, rot, undue settlement or damage to surrounding materials.

#### Test requirements

Tests should be carried out by a suitably qualified person with a detailed knowledge of:

- the material to be tested, and
- the proposed conditions of use.

The samples tested must be representative of the true nature of the material. It may be necessary to take a number of samples to find out the material characteristics of the fill.

Sulfate content should be expressed as a percentage  $SO_4$  by weight on the basis of acid soluble testing, taking full account of the recommendations of BRE Special Digest 1 Part 1.

#### Sources of fill material

Where the material is of a stable and uniform type from one source, it may only be necessary to check its suitability once. If material is variable, or from a number of sources, it should all be suitable. Regular inspections and/or testing may be required.

Where material is obtained from stockpiles, check the material is uniform. Different forms of stockpiling can affect particle size/grading. The outside of a stockpile may be weathered and may not be the same as unweathered material.

The use of recycled aggregate as fill should comply with BRE Digest 433 or other suitable guidance as agreed with NHBC.

#### Fill requiring NHBC approval

The following types of fill should not be used unless written permission has been obtained from NHBC:

- colliery shale and any other residue from mineral extraction
- slags

- furnace ashes and other products of combustion
- material obtained from demolition
- on wet sites, or sites with a high water table, crushed or broken bricks which have no limit on their soluble salt content (as defined in BS EN 771).

#### Expansive materials

Fill containing expansive materials is not acceptable for use as support to structural foundations and slabs or as backfill to associated trenches.

## INDEX

<b>A</b>		<b>L</b>		<b>V</b>	
Approval	8	Layout	3	Verification	5
<b>C</b>		<b>M</b>		Vibratory techniques	7
Compatibility	3	Materials standards	4	<b>W</b>	
<b>D</b>		<b>N</b>		Written confirmation	2
Deep compaction	6, 8	Notifications	1		
Design	2	<b>S</b>			
Design standards	1	Service trenches	3		
Drainage	3	Site investigations	1		
<b>E</b>		Sitework standards	4		
Expansive materials	8	Soil classifications	6		
<b>F</b>		Statutory requirements	1		
Fill materials	8	Stone columns	6, 7		
Foundation types	3	Stone fill	4		
<b>G</b>		Supervision	4		
Granular material	4	Suspended ground floors	4		
Ground conditions	1	<b>T</b>			
<b>H</b>		Testing	4, 5, 8		
Hazardous materials	8				

---

# Part 5

## Substructure and ground floors

---

- 5.1 Substructure and ground bearing floors
- 5.2 Suspended ground floors
- 5.3 Drainage below ground







# Chapter 5.1

## Substructure and ground bearing floors

---



# 5.1

## Substructure and ground bearing floors

### CONTENTS

	Clause	Page
<b>DESIGN</b>		
Design standards	D1	1
Statutory requirements	D2	1
Transfer of loads	D3	1
Ground conditions	D4	1
Services and drainage	D5	2
Walls below dpc	D6-D7	2
Ground below fill	D8	2
Hazardous fill	D9-D10	3
Fill deeper than 600mm	D11	3
Floor slab damp-proofing	D12	3
Damp-proof course	D13	3
Thermal insulation	D14	3
Ground floor slab	D15	4
Basements	D16	4
Provision of information	D17-D18	4
<b>MATERIALS</b>		
Materials standards	M1	5
Masonry below dpc	M2	5
Site mixed mortar	M3	5
Proprietary mortar	M4	5
Wall ties	M5	5
Wall insulation	M6	5
Fill	M7	5
Damp-proof membrane	M8	6
Concrete	M9	6
Tanking materials	M10	6
Floor insulation	M11	6
Damp-proof course materials	M12	6
<b>SITWORK</b>		
Sitework standards	S1	6
Walls below dpc	S2	6
Ground below fill	S3	7
Fill supporting ground bearing slabs	S4-S5	7
Trench backfill	S6	7
Blinding	S7	8
Damp-proofing floors	S8	8
Damp-proof course	S9	8
Laying thermal insulation	S10	8
Laying the slab	S11	8
Basements	S12	8
<b>APPENDIX 5.1-A</b>		
Materials for use as fill		9
<b>APPENDIX 5.1-B</b>		
Basement constructions		10
<b>APPENDIX 5.1-C</b>		
Typical details for basements		10
<b>INDEX</b>		12

### SCOPE

This Chapter gives guidance on meeting the Technical Requirements and recommendations for substructure, excluding foundations. It includes substructure walls, ground bearing floors (where depth of fill is not more than 600mm), basements and installation of services below dpc.

**DESIGN STANDARDS**

**5.1 - D1 Design shall meet the Technical Requirements**

Design that follows the guidance below will be acceptable for substructure and ground bearing floors.

**STATUTORY REQUIREMENTS**

**5.1 - D2 Design shall comply with all relevant statutory requirements**

Design should be in accordance with relevant Building Regulations and other statutory requirements.

**TRANSFER OF LOADS**

**5.1 - D3 Design of substructure and ground bearing floors shall ensure that loads are supported and transferred to foundations, or to the ground, without undue movement**

Studies of the site, carried out in accordance with Chapter 4.1 'Land quality - managing ground conditions' should be taken into account in the design of substructure.

Where the depth of infill exceeds 600mm, the floor must be designed as a suspended floor, as described in Chapter 5.2 'Suspended ground floors' (Design).

Loadbearing partitions should not be supported off ground bearing floors. They should have proper foundations (reference should be made to Chapter 4.4 'Strip and trench fill foundations' (each section)).

In Scotland, sleeper walls should not be built off ground bearing floors.

Movement joints should be aligned with those in the foundations. Details of movement joint design are given in Chapter 6.1 'External masonry walls' (Design).

**GROUND CONDITIONS**

**5.1 - D4 Substructure shall not be adversely affected by the ground conditions**

Items to be taken into account include:

**(a) ground hazards**

The main hazards likely to affect substructure and ground bearing floors are chemicals, particularly sulfates, contaminated material above or in the ground and waterlogged ground.

In certain parts of the country, special precautions may be necessary to reduce the entry of radon gas. Areas in England and Wales where special precautions are necessary are detailed in BRE Report 211.

When precautions are necessary they should be acceptable to NHBC.

**(b) bearing capacity of the ground**

Ground bearing floors may only be used where:

- trenches are backfilled with suitable material and the fill is properly compacted
- infill is less than 600mm in depth and properly compacted.

Where the bearing capacity and nature of the ground varies, a ground bearing floor may not be suitable, even if the depth of fill is less than 600mm. Special measures may be needed to restrict settlement, such as the use of suspended floor construction.

**(c) nature of the ground**

Shrinkable soil, expansive materials or other unstable soils may require suspended floor construction. Shrinkable soils are classified as those containing more than 35% fine particles (silt and clay) and have a modified Plasticity Index of 10% or greater (see Chapters 4.2 'Building near trees' (each section) and 5.2 'Suspended ground floors' (each section)).

A soil-testing laboratory should be consulted to verify the plasticity index of the soil.

**(d) effect of sloping ground on depth of infill**

Sloping ground may require steps in the substructure and possibly different floor levels. Where more than 600mm of infill is required at any point in a self-contained area, the floor over the whole of that area must be of suspended construction as described in Chapter 5.2 'Suspended ground floors' (Design).

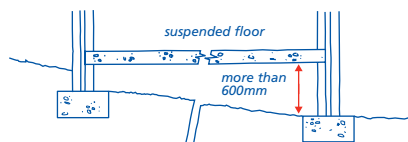

Construction on steep slopes may involve walls below dpc level acting as retaining walls. These should be designed by an Engineer where the:

- height (H) of slab above ground level is greater than 4 times the total width of wall (T)

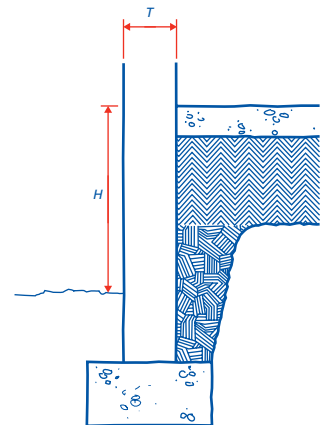
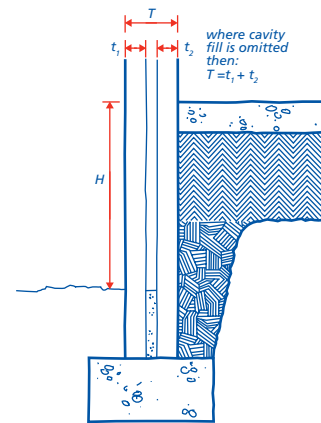

- difference between floor levels of adjacent structures (H) is greater than 4 times the total width of wall (T).

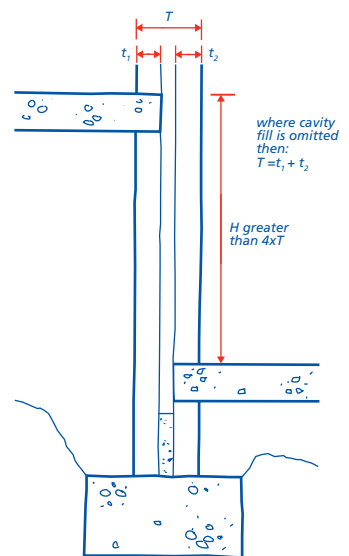

**(e) site works and construction**

Special precautions may be needed to prevent damage to the substructure from site operations on adjoining ground, such as ground treatment or surcharging due to infill.

**SERVICES AND DRAINAGE****5.1 - D5 Substructure shall not be adversely affected by services and drainage**

Items to be taken into account include:

**(a) surface water and sub-soil drainage**

Surface and/or land drainage may be needed on sites where there is a risk of waterlogging. Ground or paths adjoining the dwelling should slope away at a slight fall. Ground or path level should be at least 150mm below dpc.

Walls which act as retaining walls may require land drains, hardcore fill and suitable outlets to dispose of any sub-soil water that collects behind the wall.

**(b) existing underground services**

All existing services should be located and identified before work commences. Where existing services would be obstructed by the foundations and substructure, they should be:

- disconnected and grubbed up, or
- diverted and any remaining voids filled with concrete or grout, or
- protected where they are to remain active.

To avoid flooding around, in or under dwellings, existing active ground water drainage should be retained. Water from these drains may require diversion.

It is very difficult during a dry period to find out whether ground water drains are active, so where they are severed or disturbed, they should be re-connected to a suitable outfall.

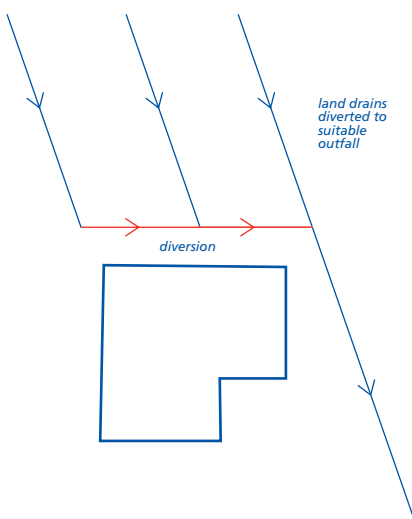
**(c) provision of new services**

It is important that the design drawings include all necessary details relating to the proposed underground services (see Clause D17).

Drain pipes passing through or under the building may require flexible connections or other means of accommodating differential movement. Further details are given in Sitework clause 5.1 - S2(e) and Chapter 5.3 'Drainage below ground' (Design and Sitework).

Services should be arranged so that future access, if required, can be obtained without affecting structural stability.

**WALLS BELOW DPC****5.1 - D6 Walls below dpc shall be capable of supporting their intended loads and, where necessary, be resistant to frost action, sulfates and other harmful or toxic materials**

Generally, masonry walls below dpc should be designed and constructed as described in Chapter 6.1 'External masonry walls' (each section) and sleeper walls as described in Chapter 4.4 'Strip and trench fill foundations' (each section).

Recommendations for the design strength of bricks, masonry blocks and mortars are given in BS EN 1996-1-1.

Frost damage occurs on saturated masonry exposed to freezing conditions. Bricks, blocks and mortars which are located between 150mm above, and 150mm below ground level, are the most likely to be damaged by frost.

**BRICKWORK**

Fletton or common bricks are usually of durability designations F1,S2 or F1,S1. If in doubt as to their suitability, bricks of F2,S2 or F2,S1 designation should be specified or the manufacturer consulted.

Where bricks of grade F1,S2 or F1,S1 are to be used in the outer leaf below dpc, or where they could be frozen when saturated, it is most important to ensure that they are durable.

If there is any doubt about the suitability of a particular brick, written confirmation should be obtained from the brick manufacturer concerning its suitability for the:

- geographical location
- location in the structure.

Calcium silicate bricks for use below dpc should be at least compressive strength class 20.

Bricks used in walls which act as retaining walls should be of a type recommended by the manufacturer for the conditions of exposure.

**BLOCKWORK**

Concrete blocks for use below dpc should comply with BS EN 771 and have:

- a density exceeding 1500kg/m<sup>3</sup>, or
- a compressive strength not less than 7.3N/mm<sup>2</sup>.

Where necessary, to resist sulfate attack and ensure adequate durability, special blocks made with a higher than normal cement content and/or with sulfate-resisting cement should be used.

If there is any doubt about the suitability of a type of block, particularly where acids or sulfates occur, written confirmation should be obtained from the block manufacturer concerning its suitability for the:

- geographical location
- location in the structure.

**MORTAR**

The selection of mortar for use below dpc should follow the recommendations given in BS EN 1996-1-1. Alternatively, the mix may be 1 : 1 : 5½, cement : lime : sand, with plasticiser.

Sulfate-resisting cement should be used where recommended by the brick manufacturer and where sulfates are present in the ground or ground water.

Proprietary mortars and admixtures should only be used strictly in accordance with the manufacturer's recommendations, taking into account the type of masonry unit and its location.

For non-clay bricks or blocks, manufacturers' recommendations should be followed.

**5.1 - D7 Walls below dpc shall be of adequate strength to resist overturning forces when acting as temporary retaining walls during construction**

Walls which act as temporary retaining walls, due to the sequence of backfilling trenches and filling the wall cavity, should be designed:

- as retaining walls, or
- by an Engineer in accordance with Technical Requirement R5, or
- so that the thickness of the leaf acting as the temporary retaining wall is as given in Sitework clause 5.1 - S2(b).

The drawings and/or specification should be detailed accordingly.

**GROUND BELOW FILL****5.1 - D8 Ground below fill shall be suitable to support ground bearing floors without undue movement**

Before fill is placed, all topsoil containing roots and vegetation should be removed and a suitable bearing surface prepared.

## HAZARDOUS FILL

**5.1 - D9 Harmful or toxic materials present in fill, or made ground below fill, shall be identified to the satisfaction of NHBC**

Details of materials, test requirements and sources of fill material are given in Appendix 5.1-A.

**5.1 - D10 The performance of the substructure shall not be affected by harmful or toxic materials present in the fill or in the ground**

Precautions should be taken to avoid adverse effects by either:

- ensuring that made ground and fill materials are free from harmful or toxic substances, or
- designing the construction to contain, resist and prevent adverse effects of such materials, by means acceptable to NHBC.

Types of fill which require special precautions to be taken are given in Appendix 5.1-A.

Where sulfates or other harmful chemicals are present in the ground at levels likely to be harmful:

- concrete for the floor slab should be:
  - of the appropriate mix to resist sulfate attack, and
  - protected by an impervious layer of 1200 gauge (0.3mm) polyethylene sheet (or 1000 gauge (0.25mm) if assessed in accordance with Technical Requirement R3 ) which may also serve as a dpm
- mortar should be in accordance with the recommendations of BS EN 1996-1-1
- concrete blocks should have a sulfate resistance appropriate for the level of sulfate in the fill or ground.

Where expansive materials are present, a suspended floor system should be used.

## FILL DEEPER THAN 600mm

**5.1 - D11 Where fill is deeper than 600mm, additional precautions shall be taken to provide satisfactory support to the floor and any imposed loads**

Ground bearing slabs are not acceptable where fill exceeds 600mm in depth.

Where the depth of fill exceeds 600mm at any point within a self-contained area, the floor construction over the whole of that area is required to be independent of the fill and capable of supporting:

- self weight
- partitions
- other imposed loads.

For details, reference should be made to Chapter 5.2 'Suspended ground floors' (Design).

## FLOOR SLAB DAMP-PROOFING

**5.1 - D12 Ground bearing floors shall resist the passage of moisture to the inside of the dwelling**

Items to be taken into account include:

### (a) ground moisture

Ground bearing concrete floor slabs should be protected against ground moisture by providing a continuous membrane, details of which are given in the Materials section. Care should be taken not to trap moisture when a combination of damp proofing and vapour control layers are used.

When the membrane is located below the slab, a blinding layer of sand should be provided to fill voids in the hardcore and so minimise the risk of puncturing the membrane.

The continuity of the membrane should be maintained as follows:

- laps in polyethylene should be at least 300mm and joints sealed, where necessary
- membranes beneath the slab should link with wall dpcs to form an impervious barrier to prevent moisture reaching the interior of the dwelling
- linking should take account of possible differential movement.

A clear cavity for at least 225mm below dpc should be maintained. When specialised foundations are used, including those for timber framed buildings, this depth may be reduced to 150mm below dpc if weep holes are provided and other necessary measures are taken to ensure that the cavity can drain freely.

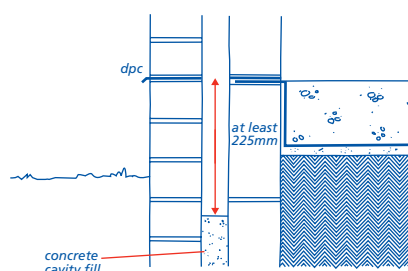

### (b) water pressure

Where ground water can exert pressure, land drainage may be necessary to prevent water entering the dwelling. At changes in floor level, eg stepped separating walls, special attention is required to ensure the continuity of the dpm.

Horizontal and vertical tanking should link with wall dpcs in a manner similar to a dpm.

## DAMP-PROOF COURSE

**5.1 - D13 Moisture from the ground shall be prevented from reaching the inside of the building**

A damp-proof course should be positioned at least 150mm above finished ground or paving level.

Horizontal dpcs should be impermeable. They should be either lapped (at least 100mm) or welded, where appropriate, and, in all cases, linked to the dpm.

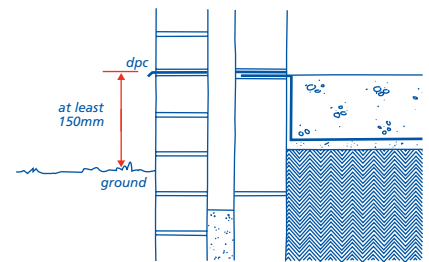

Where dwellings are 'stepped' on a sloping site, care should be taken to link dpcs and dpm properly, so that all parts of each dwelling are protected.

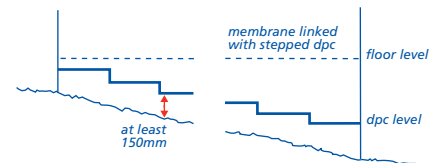

## THERMAL INSULATION

**5.1 - D14 Thermal insulation of ground bearing floors and walls below dpc shall be designed to comply with statutory requirements**

The BRE Report 'Thermal insulation: avoiding risks' discusses aspects of insulation relevant to ground bearing floors. In England and Wales account should be taken of Accredited Details.

Items to be taken into account include:

### (a) floor insulation

Thermal insulation materials for use below ground bearing slabs are given in the Materials section.

For details of thermal insulation above ground floor slabs, reference should be made to Chapter 8.3 'Floor finishes' (Design).

### (b) wall insulation

Where cavity insulation batts or slabs start below dpc level, the vertical and horizontal spacing of wall ties should be compatible with the spacing to be used above dpc level.

For details of insulating masonry walls, reference should be made to Chapter 6.1 'External masonry walls' (each section).

**(c) cold bridging**

The design should ensure that any risk of cold bridging is minimised, giving particular attention to junctions between floor and external walls.

Precautions include:

- extending cavity insulation below floor slab level
- linking floor and wall insulation
- providing perimeter insulation to floors
- facing supporting substructure with insulation.

Where dwellings are stepped or staggered, the wall forming the step or stagger may require insulation.

**GROUND FLOOR SLAB****5.1 - D15 Ground bearing floor slabs shall be of adequate strength and durability**

Appropriate mixes for ground bearing concrete floor slabs are specified in Chapter 2.1 'Concrete and its reinforcement' (Design).

Ground bearing concrete floor slabs should be not less than 100mm thick, including monolithic screed where appropriate.

**BASEMENTS****5.1 - D16 All elements (including walls, floors and foundations) forming a basement shall be suitable for their location**

The design should take account of the BCA Approved Document "Basements for dwellings". Its principles should be followed in England, Wales, Scotland and Northern Ireland.

In this clause the term "basement" means construction which is wholly or partly below ground level and for which normal damp proofing arrangements are inappropriate.

Items to be taken into account include:

**(a) structural stability**

All basements should be designed by an Engineer in accordance with Technical Requirement R5.

Information from the site investigation, carried out in accordance with Chapter 4.1 'Land quality - managing ground conditions' should be taken into account in the design of basements.

Reference should be made to Chapter 4.2 'Building near trees' where trees, hedgerows or shrubs are present.

**(b) waterproofing**

The design of the basement should take account of the current and future ground water conditions. Where it is uncertain what the future ground water conditions may be the waterproofing system

should be designed to withstand the full hydrostatic head.

Any existing land drains which are disturbed by the basement excavation should be diverted to a suitable outfall. See Clause D5.

Walls and floors below external ground level should resist moisture from reaching the internal surfaces of walls or the upper surface of a floor.

The design should ensure that the level of protection against water and moisture reaching the internal surfaces is appropriate for the proposed use. Where there is any doubt about use, the level of protection required for habitable accommodation should be provided.

Basements to be used for habitable accommodation should be designed to allow no water penetration and provide a dry environment if maintained by adequate heating and ventilation. This is referred to as "Grade 3" in the "Basements for dwellings" Approved Document.

Walls and floors to basements to be used for parking cars, for storage or as plant rooms should be designed to allow no water penetration (unless a type C drained cavity) although moisture vapour is tolerated. This is referred to as "Grade 2" in the "Basements for dwellings" Approved Document.

The design should ensure that all materials and products used in the construction of a basement are compatible and used strictly in accordance with the manufacturer's recommendations.

Proprietary waterproofing materials should comply with Technical Requirement R3.

Appendix 5.1-B shows generic basement constructions that may be acceptable to NHBC subject to appropriate detailing.

They are:

- Type A tanked protection. The water resistance is achieved by waterproofing. This system is not suitable where the water table is either variable or high and the basement walls are masonry. See "Basements for dwellings" Approved Document.

**Note**

Internal tanking is generally not acceptable.

- Type B structurally integral protection. The water resistance is achieved by the design of the concrete construction. An additional moisture barrier may be necessary. This system is not suitable where the water table is either variable or high and the design is to BS EN 1992-1-1 unless there is additional waterproofing.

- Type C drained cavity. The water resistance is achieved by collecting any water in the internal cavity system. An additional moisture barrier may be necessary. This system is reliant on collecting and disposing of any water within the cavity system to a suitable outfall. Any sumps and/or pumps will need to be accessible for maintenance.

**(c) services**

The number of services passing through basement waterproofing should be kept to a minimum.

The design should detail how any penetrations for services prevent water or damp ingress.

Further details of services and drainage are given in Clause D5 and Appendix 5.1-C.

**PROVISION OF INFORMATION****5.1 - D17 Designs and specifications shall be produced in a clearly understandable format and include all relevant information**

Clear and fully detailed drawings should be available on site to enable work to be carried out in accordance with the design.

Design drawings should include:

- all necessary plan dimensions and levels related to identified benchmarks
- information on all proposed underground services
- points of entry to the building for services
- penetration of services through the substructure, including support of the structure above
- details of trench backfill, infill and void formers
- the required sequence of trench backfill if this is relevant to the design of the walls below dpc
- work required to maintain the integrity of dpcs and dpms
- details of junctions between dpm, dpc and tanking
- details of underfloor and floor edge insulation and cavity insulation, where relevant.

**5.1 - D18 All relevant information shall be distributed to appropriate personnel**

Ensure that design and specification information is issued to site supervisors and relevant specialist subcontractors and/or suppliers.



## MATERIALS STANDARDS

### 5.1 - M1 All materials shall:

- (a) meet the Technical Requirements  
(b) take account of the design

Materials that comply with the design and the guidance below will be acceptable for substructure and ground bearing floors.

Materials for substructure and ground bearing floors should comply with all relevant standards, including those listed below. Where no standard exists, Technical Requirement R3 applies (see Chapter 1.1 'Introduction to the Standards and Technical Requirements').

References to British Standards and Codes of Practice include those made under the Construction Products Directive (89/106/EEC) and, in particular, appropriate European Technical Specifications approved by a European Committee for Standardisation (CEN).

## MASONRY BELOW DPC

### 5.1 - M2 Walls below dpc shall be capable of supporting their intended loads and, where necessary, be resistant to frost action, sulfates and other harmful or toxic materials

Recommendations for the design strength of bricks, masonry blocks and mortars are given in BS EN 1996-1-1.

#### BRICKWORK

Clay bricks should comply with BS EN 771, which classifies bricks by the durability designations shown below:

F2,S2 (Freeze/thaw resistant, Low active soluble salts)

F2,S1 (Freeze/thaw resistant, Normal active soluble salts)

F1,S2 (Moderately freeze/thaw resistant, Low active soluble salts)

F1,S1 (Moderately freeze/thaw resistant, Normal active soluble salts)

FO,S2 (Not freeze/thaw resistant, Low active soluble salts)

FO,S1 (Not freeze/thaw resistant, Normal active soluble salts)

Fletton or common bricks are usually of durability designations F1,S2 or F1,S1. If in doubt as to their suitability, bricks of F2,S2 or F2,S1 designation should be specified or the manufacturer consulted.

#### BLOCKWORK

Concrete blocks for use below dpc should comply with BS EN 771 and have:

- a density exceeding 1500kg/m<sup>3</sup>, or
- a compressive strength not less than 7.3N/mm<sup>2</sup>, or
- an assessment in accordance with Technical Requirement R3.

Proprietary blocks should comply with Technical Requirement R3.

## SITE MIXED MORTAR

### 5.1 - M3 Mortar for use in masonry below dpc level, and for bedding the dpc, shall be suitable for the location and intended use

Items to be taken into account include:

#### (a) strength and composition

Mortar should comply with the design and should take account of the strength, type and location of the masonry.

#### (b) sulfate resistance

Where the ground, ground water or the masonry contains levels of sulfates likely to be harmful, the mortar should be made with sulfate-resisting cement to BS 4027.

## PROPRIETARY MORTAR

### 5.1 - M4 Proprietary mortars shall be suitable for their intended use

Proprietary mortars and admixtures should comply with Clause M3 and should only be used strictly in accordance with the manufacturer's recommendations, taking into account the type of masonry unit and its location.

## WALL TIES

### 5.1 - M5 Wall ties shall be suitable for their intended use

Wall ties should comply with BS EN 845 or be assessed in accordance with Technical Requirement R3.

## WALL INSULATION

### 5.1 - M6 Thermal insulation materials for walls below dpc shall be suitable for their intended use

Cavity insulation materials, super lightweight blocks, blocks with face bonded insulation and blocks with integral insulation should be either:

- used in accordance with an assessment which complies with Technical Requirement R3 or
- manufactured in accordance with a British Standard and used in accordance with a relevant Code of Practice.

In Northern Ireland and the Isle of Man, it is not permitted to fill cavities with pumped thermal insulants at the time of construction.

In Scotland, it is not permitted to fill the full width of the cavity with any thermal insulants at the time of construction.

Insulants specified and installed in accordance with the following British Standards will be acceptable in England and Wales only:

- BS 6232 Thermal insulation of cavity walls by filling with blown man-made mineral fibre

- BS 6676 Thermal insulation of cavity walls using man-made mineral fibre batts (slabs).

UF foam when permitted to BS 5617, and installed by a specialist company registered by BSI in accordance with BS 5618, will be acceptable in England and Wales only.

The thickness of materials should be as required by the design.

## FILL

### 5.1 - M7 Fill, including made ground, trench backfill and infill below ground bearing floor slabs, shall:

- (a) be free from hazardous materials unless appropriate precautions are taken, and  
(b) provide consistent support to ground bearing slabs

The appropriate precautions to be taken where hazardous materials are present in fill, are detailed in Appendix 5.1-A.

The test requirements given in Appendix 5.1-A should be followed where necessary.

Fill containing expansive materials or chemicals is not acceptable for the support of ground bearing slabs.

Well graded, inert fill containing no hazardous materials, which passes a 150mm x 150mm screen in all directions, normally will be suitable as support for ground bearing floors.

[For further guidance refer to BRE DG 522 'Hardcore for supporting ground floors of buildings'.](#)

### DAMP-PROOF MEMBRANE

**5.1 - M8 Selection of damp-proof membrane materials shall take account of the nature of the construction and the possibility of damage**

For solid floors, requirements vary with the location of the damp-proof membrane as shown in the following table.

Selection of damp-proof membrane materials

Below the slab

- Polyethylene sheet not less than 1200 gauge (0.3mm) (or 1000 gauge (0.25mm) if assessed in accordance with Technical Requirement R3 of Chapter 1.1)
- Bitumen sheet to BS 743 'Materials for damp-proof courses'

In a sandwich construction

- Any sheet of material given in the previous column
- Hot applied asphalt to BS 6925, pitch or bitumen
- Three full coats of cold applied bituminous solutions, cold tar, pitch or rubber emulsion
- Composite polyethylene and bitumen self-adhesive not less than 0.6mm thick

On the surface of the slab

- Hot applied asphalt to BS 6925 or pitch mastic
- Cold applied pitch/epoxy resin

### CONCRETE

**5.1 - M9 Concrete shall be of a mix design and be reinforced, where necessary, to safely support the floor loads and to achieve sufficient durability to resist chemical and frost action**

For guidance on the specification and use of concrete, concrete additives and reinforcement, reference should be made to Chapter 2.1 'Concrete and its reinforcement' (each section).

### TANKING MATERIALS

**5.1 - M10 Walls and floors of basements shall incorporate tanking materials to adequately resist the passage of water and moisture**

Tanking materials should be:

- asphalt to BS 6925 or BS 6577, or
- a proprietary system or product assessed in accordance with Technical Requirement R3.

Polyethylene sheet (such as 'Polythene' or 'Visqueen') is not acceptable for tanking.

### FLOOR INSULATION

**5.1 - M11 Thermal insulation for ground bearing floors shall be suitable for its intended use**

Thermal insulation materials for use below ground bearing slabs should have:

- appropriate density for the location
- low water absorption.

Insulation to be positioned below both the slab and dpm should be resistant to ground contaminants.

The following materials are acceptable for use as insulation:

- expanded polystyrene boards (grade EPS 70) to BS EN 13163
- a proprietary material assessed in accordance with Technical Requirement R3.

For details of floor insulation materials above ground floor slabs, reference should be made to Chapter 8.3 'Floor finishes' (Materials).

### DAMP-PROOF COURSE MATERIALS

**5.1 - M12 Materials for damp-proof courses shall adequately resist the passage of moisture**

Acceptable materials for dpcs are:

- bitumen to BS 6398
- polyethylene to BS 6515 (except below copings and in parapets); polyethylene dpcs should be black and not less than 0.5mm thick
- a proprietary material assessed in accordance with Technical Requirement R3.

Dpcs and flexible cavity trays should be of the correct dimensions to suit the detailed design.

Brick dpcs should consist of two courses of engineering bricks, laid breaking joint and bedded and jointed in a 1 : ¼ : 3, cement : lime : sand, or equivalent, mortar. Brick dpcs are only suitable to resist the upward movement of moisture.

For complicated junctions, preformed cavity trays are recommended. Care may be needed to ensure the correct type and shape is ordered.

### SITWORK STANDARDS

**5.1 - S1 All sitework shall:**

- meet the Technical Requirements
- take account of the design
- follow established good practice and workmanship

Sitework that complies with the design and the guidance below will be acceptable for substructure and ground bearing floors.

### WALLS BELOW DPC

**5.1 - S2 Walls below dpc shall be constructed in accordance with the design**

Items to be taken into account include:

**(a) concrete cavity fill**

A clear cavity for at least 225mm below dpc should be maintained. When specialised foundations are used, including those for timber framed buildings, this depth may be reduced to 150mm below dpc provided that weep holes and other necessary measures are taken to ensure that the cavity can drain freely.

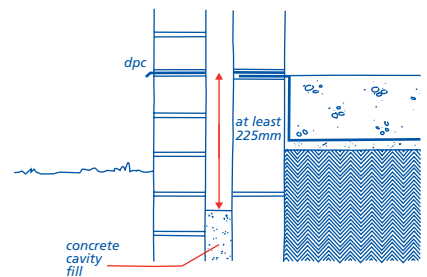

**(b) construction sequence**

Where backfill is placed and compacted in one side of the foundation trench before the other side is backfilled, the wall will be acting as a temporary retaining wall.

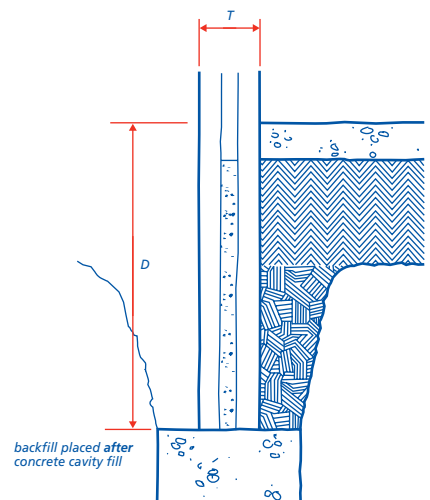
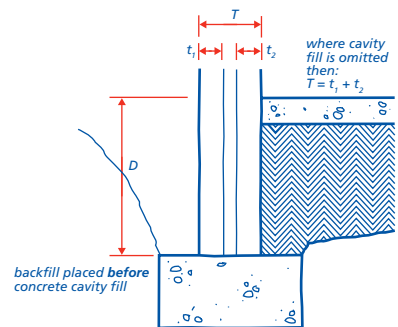



In such cases, the wall should be either designed by an Engineer in accordance with Technical Requirement R5 or the thickness (T) should be increased as indicated in the following table:

Depth (D) of filled trench [m]	Minimum thickness (T) of wall leaf supporting fill [mm]
Up to 1.1	200
1.1 to 1.4	300
1.4 to 1.7	400
1.7 to 2.0	500

**Note**

This table is only applicable to the temporary condition and where problems such as hydrostatic pressure are not present.

**(c) workmanship**

Workmanship below dpc level should be of a high standard to avoid the necessity for costly repairs. Details of cavity wall construction are given in Chapter 6.1 'External masonry walls' (Sitework).

**(d) wall ties**

Where cavity insulation batts or slabs start below dpc level, the vertical and horizontal spacing of wall ties should be compatible with the spacing to be used above dpc level.

**(e) services and service entries**

Underground services should be installed as described in Chapters 8.1 'Internal Services' (Sitework) and 5.3 'Drainage below ground' (Sitework), or provision made for their later installation. Where services penetrate walls, the following alternatives are acceptable:

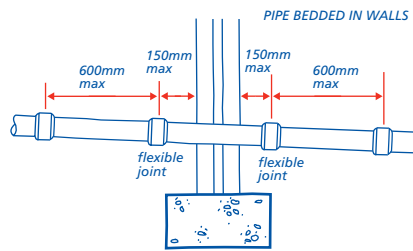
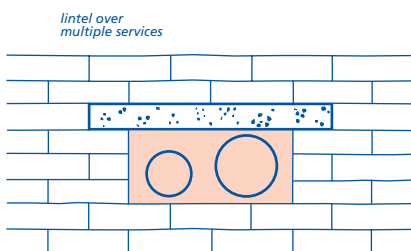
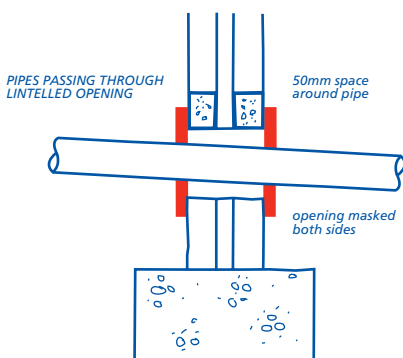

Services should be sleeved where they pass through a structural element.

When unidentified services, ducts, cables or pipes are exposed, advice should be sought from local offices of statutory undertakings and service supply companies.

**GROUND BELOW FILL**

**5.1 - S3 Ground shall be adequately prepared to provide consistent support to the fill and the ground bearing slab**

All vegetable soil and organic matter, including tree roots, should be removed to provide an even bearing surface.

Ground bearing floors may be used only where:

- trenches are backfilled with properly compacted material
- infill is less than 600mm in depth and properly compacted
- the ground is suitable to support floor loads and any other loads.

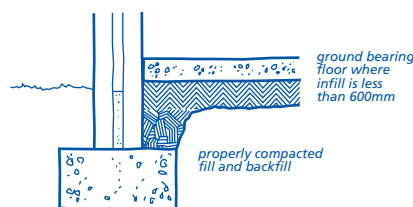

Where more than 600mm of infill is required at any point within a self-contained area, or the bearing capacity and nature of the ground varies, the floor over the self-contained area should be of suspended construction. Reference should be made to Chapter 5.2 'Suspended ground floors' (Sitework).

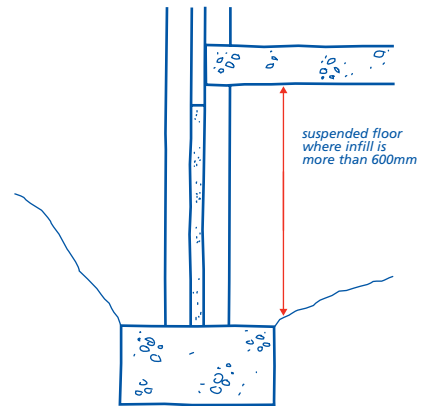

**FILL SUPPORTING GROUND BEARING SLABS**

**5.1 - S4 Fill, including made ground, trench backfill and infill, shall provide full and consistent support to any ground bearing slab**

Well graded inert fill without hazardous materials, which passes a 150mm x 150mm screen in all directions, will normally be suitable as support for a ground floor slab.

Fill should be placed and mechanically compacted in layers not exceeding 225mm deep, to form a stable mass.

**5.1 - S5 The performance of the substructure and ground bearing slab shall not be affected by any hazardous materials in the fill**

Types of fill which require special precautions to be taken are given in Appendix 5.1-A.

Where sulfates are present in the ground at levels likely to be harmful:

- the floor slab should be of the appropriate mix to resist sulfate attack and be protected by an impervious layer of 1200 gauge (0.3mm) polyethylene sheet (or 1000 gauge (0.25mm) if assessed in accordance with Technical Requirement R3) which may also serve as a dpm
- mortar in substructure walls should contain sulfate resisting cement
- concrete blocks in substructure walls should have a sulfate resistance appropriate for the level of sulfate in the fill or ground.

Expansive materials are not acceptable for use as fill supporting ground bearing slabs.

For further guidance refer to BRE DG 522 'Hardcore for supporting ground floors of buildings'.

**TRENCH BACKFILL**

**5.1 - S6 Backfill to trenches shall be adequately compacted**

To avoid settlement at junctions between the substructure wall and the ground

# 5.1

## Substructure and ground bearing floors

bearing floor, trenches should be backfilled with solid material, graded and compacted according to the guidance given in Clause S4. Alternatively, concrete may be used (see Chapter 2.1 'Concrete and its reinforcement' (Sitework)).

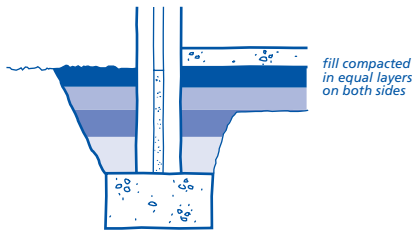

Fill should be placed in layers of equal thickness to both sides of substructure walls so that compaction on one side is not more than one layer ahead of the other. Where this is not possible, the wall will be acting as a retaining wall and the advice given in Clause S2(b) should be followed.

### BLINDING

**5.1 - S7 Blinding shall provide a suitable surface for the materials above**

Fill should be blinded sufficiently to receive concrete (or dpm, if required) using the minimum thickness necessary to give a suitable surface. Concrete blinding may be needed where voids in the fill could result in loss of fines from the blinding. Where hardcore fill is used, smooth blinding, eg sand or other suitable fine material, is essential to avoid puncturing a sheet dpm. Where the ground floor is to be reinforced, the blinding should be firm and even to give good support for the reinforcement and to maintain the design cover, using reinforcement stools, where necessary.

### DAMP-PROOFING FLOORS

**5.1 - S8 Ground bearing floors shall be resistant to the passage of moisture from the ground**

A ground bearing concrete floor should be protected from ground moisture by a continuous damp-proof membrane.

The continuity of the membrane should be maintained as follows:

- laps in polyethylene should be at least 300mm and joints sealed, where necessary
- membranes beneath the slab should link with wall dpcs to form an impervious barrier to prevent moisture reaching the interior of the dwelling
- linking should take account of possible differential movement.

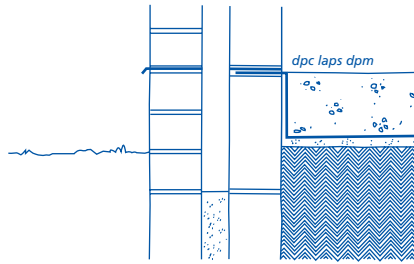

Where dwellings are stepped down a sloping site, the dpcs and dpms should be linked so that all parts of each dwelling are protected.

### DAMP-PROOF COURSE

**5.1 - S9 Moisture from the ground shall be prevented from reaching the inside of the building**

A damp-proof course should be positioned at least 150mm above finished ground or paving level and should link with any ground floor dpm.

The dpc should be of the correct width and fully bedded.

For guidance concerning setting and bedding dpcs, reference should be made to Chapter 6.1 'External masonry walls' (Sitework).

### LAYING THERMAL INSULATION

**5.1 - S10 Installation of thermal insulation shall ensure that the full thermal performance of the floor is achieved**

Insulation boards should be tightly butted together to maintain insulation continuity.

Where the insulation is turned up vertically at the edge of the slab, the edge should be protected whilst concrete is being poured and tamped.

Where edge insulation is within the cavity external wall, the insulation material should be supported on wall ties as described in Clause S2(d) and Chapter 6.1 'External masonry walls' (Sitework).

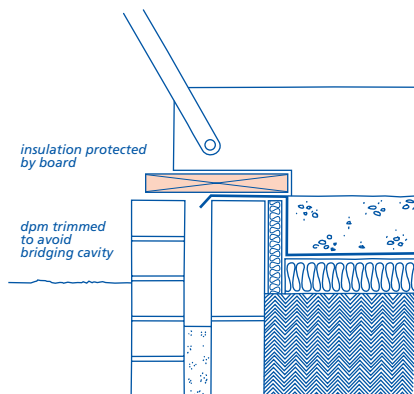

### LAYING THE SLAB

**5.1 - S11 Ground bearing floors shall be reasonably level and effectively impervious to moisture**

All underfloor services and ducts should be installed and, where appropriate, tested before concreting is started.

Care should be taken to ensure that all joints and junctions between damp-proofing membranes, wall dpcs or tanking in substructure walls are undamaged, especially while the concrete for the ground slab is being poured.

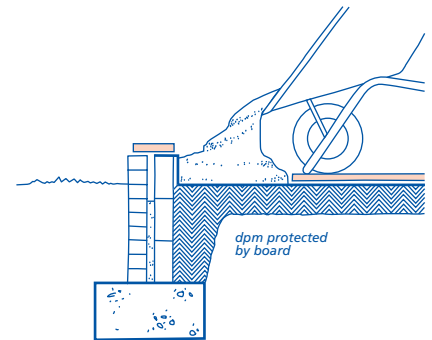

Details of screeds laid monolithically with floor slabs are given in Chapter 8.3 'Floor finishes' (Sitework).

Details of mixing, placing and curing concrete are given in Chapter 2.1 'Concrete and its reinforcement' (Sitework).

### BASEMENTS

**5.1 - S12 Basements shall be constructed in accordance with the design**

Appendix 5.1-B gives details of the different types of basement construction that may be acceptable to NHBC subject to appropriate detailing.

Items to be taken into account include:

**(a) detailing and application of tanking materials**

Appendix 5.1-C gives typical details of the critical areas in basement construction to avoid water penetration.

The design will specify the method of tanking to be used. This should not be changed without consulting the designer.

Where required by the design the waterproofing system should be applied by a specialist contractor experienced in that system. Installers should be made fully aware of the design and the manufacturer's recommendations for the preparation and installation.

Tanking which is being installed or is complete should be protected to prevent damage.

A suitable protection board should be provided against the waterproofing

material to avoid damage. Where the waterproofing system is protected by backfilled material this should be placed carefully in layers to prevent damage.

**(b) junctions, abutments and services**  
 Details of how junctions and abutments are formed should be provided to site personnel.

Where services pass through the waterproofing system they should be in accordance with the design.

The basement waterproofing system should be linked to the damp proofing arrangements for the superstructure. Any lap joints should be protected against damage during construction.

See Appendix 5.1-C.

APPENDIX 5.1-A

Materials for use as fill

<b>Hazardous materials</b>	The following materials require testing to ensure their suitability for use as fill to support ground bearing slabs or as backfill to associated trenches: <ul style="list-style-type: none"> <li>• acid wastes</li> <li>• reactive materials</li> <li>• materials that include sulfates (eg gypsum)</li> <li>• organic materials</li> <li>• toxic materials</li> <li>• materials that cause noxious fumes, rot, undue settlement or damage to surrounding materials.</li> </ul>
<b>Test requirements</b>	Tests should be carried out by a suitable qualified person with a detailed knowledge of: <ul style="list-style-type: none"> <li>• the material to be tested, and</li> <li>• the proposed conditions of use.</li> </ul> The samples tested must be representative of the true nature of the material. It may be necessary to take a number of samples to find out the material characteristics of the fill. Tests for sulfate content should be carried out in accordance with the recommendations of BRE Special Digest 1 (third edition).
<b>Sources of fill material</b>	Where the material is of a stable and uniform type from one source, it may only be necessary to check its suitability once. If material is variable, or from a number of sources, it should all be suitable. Regular inspections and/or testing may be required. Where industrial waste is permitted as fill material, it is essential that sufficient testing is carried out to ensure suitability. Where material is obtained from stockpiles, check the material is uniform. Different forms of stockpiling can affect particle size/grading. The outside of a stockpile may be weathered and may not be the same as unweathered material.
<b>Fill requiring NHBC approval</b>	The following types of fill should not be used unless written permission has been obtained from NHBC: <ul style="list-style-type: none"> <li>• colliery shale and any other residue from mineral extraction</li> <li>• slags</li> <li>• furnace ashes and other products of combustion</li> <li>• material obtained from demolition</li> <li>• on wet sites, or sites with a high water table, crushed or broken bricks which have S1 designation (as defined in BS EN 771).</li> </ul>
<b>Expansive materials</b>	Fill containing expansive materials is not acceptable for use as support to ground bearing slabs or as backfill to associated trenches.

For further guidance refer to BRE DG 522 'Hardcore for supporting ground floors of buildings'.

# 5.1

## Substructure and ground bearing floors

### APPENDIX 5.1-B

#### Basement constructions

This Appendix shows the three types of basement constructions.

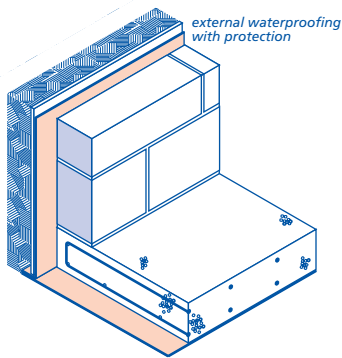

**Type A structure - tanked protection**  
(water resistance reliant on waterproofing)

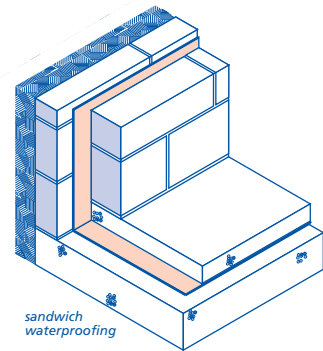

**Type A structure - tanked protection**  
(water resistance reliant on waterproofing)

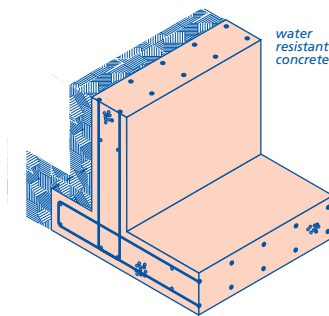

**Type B structure - structurally integral protection (water-resistant concrete)**  
(water resistance reliant specifically on the concrete construction but may be combined with additional waterproofing)

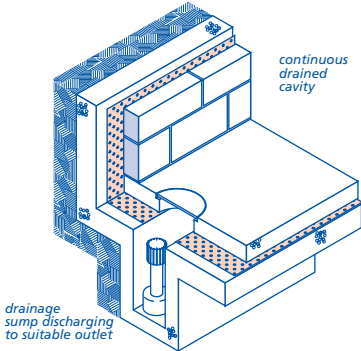

**Type C structure - drained cavity**  
(water resistance reliant on collecting and disposing of any water within the internal cavity system)

### APPENDIX 5.1-C

#### Typical details for basements

This Appendix contains generic details for basements. Because of the variations between different waterproofing systems, they should not be used as construction details. The manufacturer of the tanking system should be consulted.

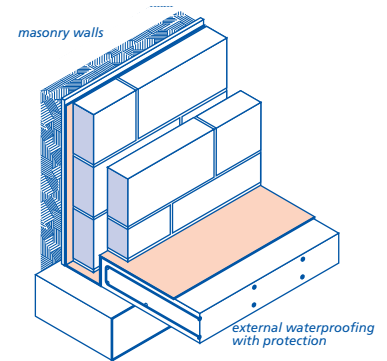

**Type A structure**  
Strip foundation without starter bars

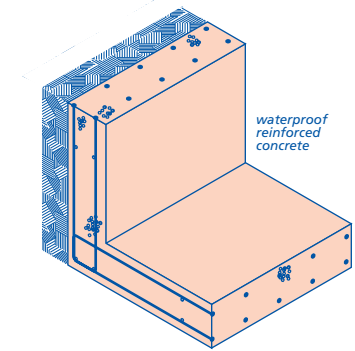

**Type B structure**  
Integral protection - water-resisting concrete

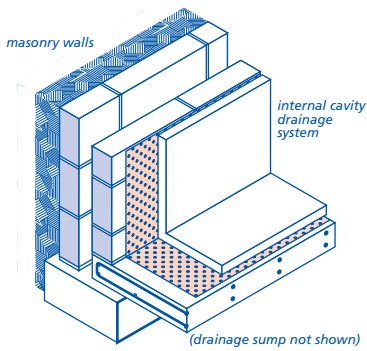

**Type C structure**  
Strip foundation without starter bars

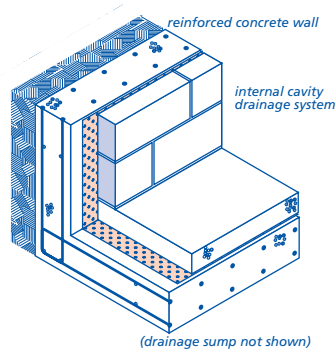

**Type C structure**  
Drained cavity construction

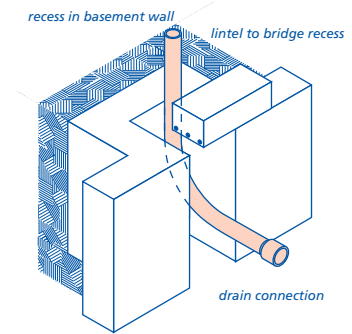

Drainage connection avoiding penetration of the waterproofing system by the soil stack

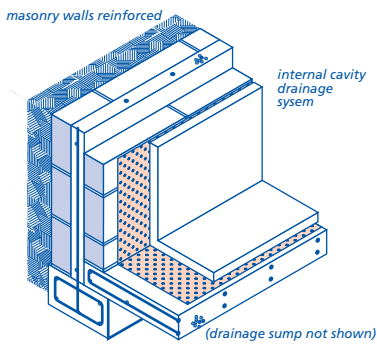

**Type C structure**  
Strip or piled foundation with starter bars

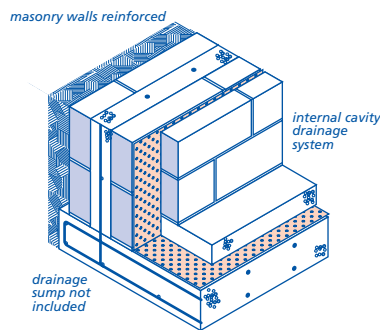

**Type C structure**  
Reinforced masonry on concrete raft

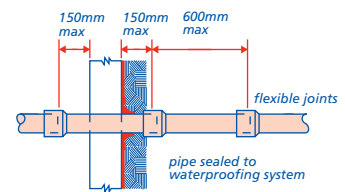

Drainage connection penetrating basement wall

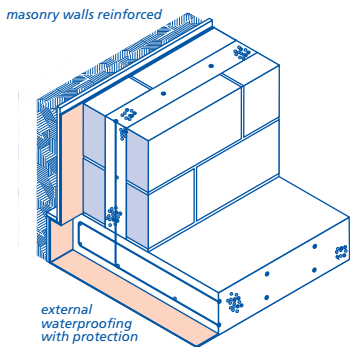

**Type A structure**  
Reinforced masonry on concrete raft

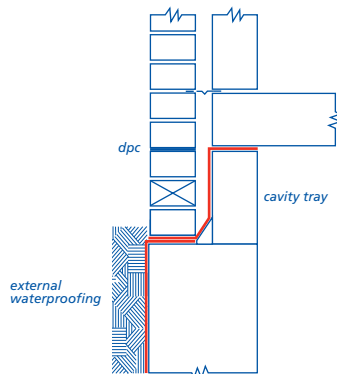

Example of linking waterproofing with DPC/cavity tray

# 5.1

## Substructure and ground bearing floors

### INDEX

<b>B</b>		<b>G</b>		<b>S</b>	
Backfill	7	Ground conditions	1	Services	2, 7
Basement constructions	10	Ground hazards	1	Site-mixed mortar	5
Bearing capacity of ground	1	Ground moisture	3	Sloping ground	1
Blinding	8	<b>H</b>		Statutory references	1
Blockwork	2, 5	Hazardous fill	3, 9	Statutory requirements	1
Brickwork	2, 5	<b>I</b>		Sulfate resistance	5
<b>C</b>		Insulation	3, 5, 6, 8	Surface water	2
Cold bridging	4	<b>M</b>		<b>T</b>	
Concrete	6	Masonry below dpc	5	Tanking materials	6
<b>D</b>		Mortar	52, 5	Test requirements	9
Damp-proofing	3, 8	<b>N</b>		Thermal insulation	3, 6, 8
Damp proof course	3, 6, 8	Nature of ground	1	Transfer of loads	1
Damp proof membrane	6	NHBC approval	9	Typical details	10
Depth of infill	1, 3	<b>P</b>		<b>W</b>	
Drainage	2	Proprietary mortar	5	Wall ties	5, 7
<b>E</b>		Provision of information	4	Walls below dpc	2, 3, 5, 6
Expansive materials	9			Water pressure	3
<b>F</b>				Waterproofing	4
Fill	2, 3, 5, 7, 9				
Floor slab	3				

# Chapter 5.2

## Suspended ground floors

---



# 5.2 Suspended ground floors

## CONTENTS

	Clause	Page
<b>DESIGN - General</b>		
Design standards	D1	1
Statutory and other requirements	D2	1
Resistance to ground contaminants	D3-D4	1
<b>DESIGN - In-situ concrete</b>		
Structural stability	D5	1
Resistance to moisture	D6	1
Thermal insulation	D7	1
Floor finishes and decking	D8	1
<b>DESIGN - Precast concrete</b>		
Structural stability	D9	1
Resistance to moisture	D10	2
Thermal insulation	D11	2
Floor finishes and decking	D12	2
<b>DESIGN - Timber</b>		
Structural stability	D13	2
Structural timber	D14	2
Trimmers	D15	2
Strutting	D16	2
Joist hangers	D17-D18	2
Joist support at separating walls	D19	2
Intermediate support	D20	2
Floor decking	D21	3
Damp-proofing	D22	3
Thermal insulation	D23	3
<b>DESIGN - Information</b>		
Provision of information	D24-D25	3
<b>MATERIALS</b>		
Materials standards	M1	3
Concrete and reinforcement	M2	4
Proprietary systems	M3	4
Timber	M4	4
Damp-proofing and thermal insulation materials	M5	4
<b>SITWORK</b>		
Sitework standards	S1	4
Ventilation and damp-proofing	S2-S3	4
Construction of floors	S4	4
Thermal insulation	S5	4
Floor finishes	S6	4
Floor decking : general	S7-S8	5
Softwood boarding	S9	5
Chipboard flooring	S10	5
Oriented strand board flooring	S11	5
Other floor decking	S12-S13	5
INDEX		5

## SCOPE

This Chapter gives guidance on meeting the Technical Requirements and recommendations for suspended ground floors of in-situ and precast concrete and timber joists.



**DESIGN STANDARDS****5.2 - D1 Design shall meet the Technical Requirements**

Design that follows the guidance below will be acceptable for suspended ground floors.

**STATUTORY AND OTHER REQUIREMENTS****5.2 - D2 Design of suspended ground floors shall comply with all relevant statutory and other requirements**

Design should be in accordance with relevant Building Regulations and other statutory requirements.

NHBC requires ground floors to be constructed as suspended floors in the following situations:

- where the depth of fill exceeds 600mm, as described in Chapter 5.1 'Substructure and ground bearing floors' (Design)
- where soil swelling may occur, as described in Chapter 4.2 'Building near trees'
- on sites which have been subject to vibratory ground improvement, as described in Chapter 4.6 'Vibratory ground improvement techniques'
- where ground or fill is not suitable to support ground bearing slabs. For suitable fill providing temporary support to suspended floors, refer to Chapter 5.1 'Substructure and ground bearing floors' Appendix 5.1-A.

**RESISTANCE TO GROUND CONTAMINANTS****5.2 - D3 Design shall ensure that adequate measures are taken against adverse effects of ground contaminants and radioactive materials**

Any contaminants in or above the ground should be identified to the satisfaction of NHBC, following the guidance given in the appropriate British Standard.

Where necessary, precautions against danger to health caused by contaminants should be taken, as described in the Appendix 'Introduction to remedial measures' to Approved Document C1/2/3 and other Building Regulation documents.

**5.2 - D4 Design shall provide adequate protection against radon gas**

In certain parts of the country, special precautions may be necessary to reduce the entry of radon gas. Areas in England and Wales where special precautions are necessary are detailed in BRE Report 211.

When precautions are necessary, they should be acceptable to NHBC.

**In-situ concrete****STRUCTURAL STABILITY****5.2 - D5 In-situ concrete suspended ground floors shall be designed to transmit all loads safely to the supporting structure without undue movement**

Items to be taken into account include:

**(a) dead and imposed loads**

Loads should be calculated in accordance with BS EN 1991-1-1.

Suspended in-situ concrete ground floors should be designed either:

- by an Engineer in accordance with Technical Requirement R5, or
- in accordance with BS 8103 Part 4.

**(b) end bearings**

Bearings on supporting walls should be designed either:

- by an Engineer in accordance with Technical Requirement R5, or
- in accordance with BS 8103 Part 4.

**RESISTANCE TO MOISTURE****5.2 - D6 In-situ concrete suspended ground floors shall be designed to resist the passage of moisture to the inside of the building**

Items to be taken into account include:

**(a) damp-proofing**

Dampness from the ground and supporting structure should be prevented from reaching the floor by use of dpms and dpms.

**(b) linking dpm with dpc**

Damp-proofing of suspended ground floors should be linked with any damp-proofing of the supporting structure in order to provide continuous protection.

Where there is a risk of sulfate attack, a polyethylene sheet dpm, not less than 1200 gauge (0.3mm) (or 1000 gauge (0.25mm) if assessed in accordance with Technical Requirement R3) should be used, properly lapped.

**THERMAL INSULATION****5.2 - D7 Thermal insulation of in-situ concrete suspended ground floors shall be designed to comply with statutory requirements**

The BRE report 'Thermal insulation: avoiding risks' discusses aspects of insulation relevant to suspended ground floors. In England and Wales account should be taken of Accredited Details.

Items to be taken into account include:

- (a) insulation placed below the floor slab**  
Insulation below the ground floor slab should:
  - be placed on a suitable compacted and even substrate

- have low water absorption
- be resistant to ground contaminants
- be strong enough to support wet construction loads
- be compatible with any dpm.

Suitable insulating materials are described in the Materials section.

**(b) insulation placed above the floor slab**

For guidance on insulation above the floor slab, reference should be made to Chapter 8.3 'Floor finishes' (Design and Materials).

**(c) cold bridging**

The design should ensure that any risk of cold bridging is minimised, giving particular attention to junctions between floor and external walls.

Precautions include:

- extending cavity insulation below floor slab level
- linking floor and wall insulation
- providing perimeter insulation to floors
- facing the supporting substructure with insulation.

**FLOOR FINISHES AND DECKING****5.2 - D8 Finishes and decking to in-situ concrete suspended ground floors shall be suitable for their intended use**

Details of finishes and decking are given in Chapter 8.3 'Floor finishes' (each section) and Chapter 6.4 'Timber and concrete upper floors'.

**Precast concrete****STRUCTURAL STABILITY****5.2 - D9 Precast concrete suspended ground floors shall be designed to transmit all loads safely to the supporting structure without undue movement**

Items to be taken into account include:

**(a) dead and imposed loads**

Loads should be calculated in accordance with BS EN 1991-1-1

Precast concrete suspended ground floors should be:

- designed by an Engineer in accordance with Technical Requirement R5, or
- proprietary systems which have been assessed in accordance with Technical Requirement R3, or
- chosen from manufacturers' details which are based on recognised Standards and Codes of Practice.

**(b) end bearings**

Bearings on supporting walls should be as recommended by the manufacturer, and in no case less than 90mm.

# 5.2 Suspended ground floors

## RESISTANCE TO MOISTURE

**5.2 - D10 Precast concrete suspended ground floors shall be designed to resist the passage of moisture to the inside of the building**

Items to be taken into account include:

**(a) damp-proofing**

The supporting structure should, wherever necessary, incorporate adequate damp-proofing measures to prevent dampness from reaching the floor as described in the following Chapters:

5.1 'Substructure and ground bearing floors' (each section)

6.1 'External masonry walls' (each section).

**(b) ventilation of underfloor voids**

A minimum void of not less than 150mm should be provided below the underside of floor slabs and beams.

On shrinkable soil where heave could take place, allowance should be made for the void to accommodate the following movements according to the shrinkage potential of the soil:

- high potential - 150mm
- medium potential - 100mm
- low potential - 50mm.

Voids should be ventilated by openings providing not less than 1500mm<sup>2</sup> per metre run of external wall or 500mm<sup>2</sup> per m<sup>2</sup> of floor area, whichever gives the greater opening area.

Ventilation openings should be provided on at least two opposite sides. Where this is not possible, effective cross ventilation from opposite sides should be provided by a combination of openings and air ducts.

Where the finished level below the floor is lower than the finished adjoining ground level, appropriate drainage should be provided.

**(c) damp-proofing of suspended floors**

It may not be necessary to provide additional damp-proofing where the:

- underfloor void is ventilated and dpccs are provided under bearings of precast floors in accordance with CP 102
- ground below the floor is effectively drained (if excavated below the level of the surrounding ground).

Vapour control layers may be necessary to protect floor finishes and should be positioned in accordance with the manufacturer's recommendations (reference should be made to Chapter 8.3 'Floor finishes' (each section)).

**(d) linking dpm with dpc**

Where provided, damp-proofing of suspended ground floors should be linked with any damp-proofing of the supporting structure in order to provide continuous protection.

## THERMAL INSULATION

**5.2 - D11 Thermal insulation of precast concrete suspended ground floors shall be designed to comply with statutory requirements**

The BRE report 'Thermal insulation: avoiding risks' discusses aspects of insulation relevant to suspended ground floors. In England and Wales account should be taken of Accredited Details.

Items to be taken into account include:

**(a) insulation above floor slab**

For guidance on insulation above a floor slab, reference should be made to Chapter 8.3 'Floor finishes' (each section).

**(b) cold bridging**

The design should ensure that any risk of cold bridging is minimised, giving particular attention to junctions between floor and external walls.

Precautions include:

- extending cavity insulation below floor slab level
- linking floor and wall insulation
- providing perimeter insulation to floors
- facing the supporting structure with insulation.

## FLOOR FINISHES AND DECKING

**5.2 - D12 Finishes and decking to precast concrete suspended ground floors shall be suitable for their intended use**

Details of finishes and decking are given in Chapter 6.4 'Timber and concrete upper floors' and Chapter 8.3 'Floor finishes' (each section).

### Timber

## STRUCTURAL STABILITY

**5.2 - D13 Timber suspended ground floors, including the decking material, shall be designed to:**

- (a) support self weight, dead loads and imposed loads**
- (b) transmit loads safely to the supporting structure**
- (c) not deflect unduly**
- (d) take account of the adverse effects of shrinkage and movement**

For guidance, reference should be made to Chapter 6.4 'Timber and concrete upper floors' (Design).

## STRUCTURAL TIMBER

**5.2 - D14 Structural timber grades and sizes shall be adequate for the spans and imposed loads**

For guidance, reference should be made to Chapter 6.4 'Timber and concrete upper floors' (Design and Materials).

## TRIMMERS

**5.2 - D15 Where trimming is necessary, adequately sized timbers shall be used**

For guidance, reference should be made to Chapter 6.4 'Timber and concrete upper floors' (Design and Sitework).

## STRUTTING

**5.2 - D16 Strutting shall be adequate to limit the twisting of joists**

For guidance, reference should be made to Chapter 6.4 'Timber and concrete upper floors' (Design and Sitework).

## JOIST HANGERS

**5.2 - D17 Joist hangers shall be suitable for the joist width and depth, the strength of masonry and the required load**

For guidance, reference should be made to Chapter 6.4 'Timber and concrete upper floors' (each section).

**5.2 - D18 Adequate end bearings shall be provided for joists and joist hangers**

For guidance, reference should be made to Chapter 6.4 'Timber and concrete upper floors' (Design and Sitework).

## JOIST SUPPORT AT SEPARATING WALLS

**5.2 - D19 Joists shall be correctly supported at masonry separating walls**

For guidance, reference should be made to Chapter 6.4 'Timber and concrete upper floors' (Design and Sitework).

## INTERMEDIATE SUPPORT

**5.2 - D20 Sleeper walls shall adequately support the floor joists**

For guidance, reference should be made to Chapter 4.4 'Strip and trench fill foundations' (Design and Sitework).

## FLOOR DECKING

### 5.2 - D21 Appropriate materials for floor decking shall be used

Items to be taken into account include:

- (a) decking and joist centres
- (b) resistance to moisture
- (c) fixing

For guidance, reference should be made to Chapter 6.4 'Timber and concrete upper floors' (each section).

## DAMP-PROOFING

### 5.2 - D22 Design of timber suspended ground floors shall ensure that the floors are not adversely affected by moisture

Items to be taken into account include:

- (a) damp-proofing of supporting structure

The supporting structure should include damp-proofing to prevent moisture penetrating to the suspended floor, as described in Chapter 6.1 'External masonry walls' (each section).

Where the finished level below the floor is lower than the finished adjoining ground level:

- appropriate drainage should be provided, or
- the structure should be tanked.

- (b) resistance to ground moisture

Provision should be made to prevent ground moisture affecting timber floor construction.

This can be achieved by either:

- 50mm concrete or 50mm fine aggregate on a polyethylene membrane laid on 50mm sand blinding, or
- 100mm concrete.

In Scotland, the deemed-to-satisfy specification of the statutory regulations should be followed.

Where necessary, oversite concrete should be protected against sulfate attack by the use of a polyethylene sheet dpm, not less than 1200 gauge (0.3mm) (or 1000 gauge (0.25mm) if assessed in accordance with Technical Requirement R3) properly lapped.

- (c) ventilation of underfloor voids

A minimum ventilation void of 150mm should be provided below floor joists or 75mm below any wall plate.

On shrinkable soil where heave could take place, an allowance for movement should be added to the underfloor ventilation requirement to determine the minimum dimension of the underfloor void. The allowance for movement relates to the shrinkage potential of the soil as follows:

- high potential - 150mm
- medium potential - 100mm
- low potential - 50mm.

Voids should be ventilated by openings providing not less than 1500mm<sup>2</sup> per metre run of external wall or 500mm<sup>2</sup> per m<sup>2</sup> of floor area, whichever gives the greater opening area.

Ventilators should be spaced at not more than 2m centres and within 450mm of each end of any wall. Air bricks should be ducted through cavities and be unobstructed.

Every part of the void under a timber suspended ground floor should be thoroughly ventilated through openings on at least two opposite sides. Where this is not possible, effective cross ventilation from opposite sides should be provided by a combination of openings and air ducts.

Provision should be made for ventilation through partitions and sleeper walls. If necessary, pipe ducts should be incorporated in adjoining solid floors, separating walls or other obstructions. Ventilation should not be obtained through a garage.

## THERMAL INSULATION

### 5.2 - D23 Thermal insulation of timber suspended ground floors shall be designed to comply with statutory requirements

The BRE report 'Thermal insulation: avoiding risks' discusses aspects of insulation relevant to suspended ground floors. In England and Wales account should be taken of Accredited Details.

Items to be taken into account include:

- (a) positioning of insulation

Insulation may be:

- insulation quilt, or
- rigid insulation.

Insulation quilt should be supported between joists.

Rigid insulation boards should be adequately supported on battens fixed to the sides of joists.

- (b) cold bridging

The design should ensure that any risk of cold bridging is minimised, giving particular attention to junctions between floor and external walls.

Precautions include:

- extending cavity insulation below floor level
- linking floor and wall insulation
- providing perimeter insulation to floors
- facing the supporting substructure with insulation.

## Information

### PROVISION OF INFORMATION

#### 5.2 - D24 Designs and specifications shall be produced in a clearly understandable format and include all relevant information

Clear and fully detailed drawings should be available on site to enable work to be carried out in accordance with the design.

Design drawings should include:

- all necessary plan dimensions and levels related to identified benchmarks
- details of loadbearing walls
- minimum bearing dimensions
- information on all proposed underground services
- points of entry to the building for services
- penetration of services through the substructure, including support of the structure above
- details of trench backfill, infill and void formers
- the required sequence of trench backfill if this is relevant to the design of the walls below dpc
- work required to maintain the integrity of dpcs and dpms
- details of junctions between dpm, dpc and tanking
- details of underfloor and floor edge insulation and cavity insulation, where relevant.

#### 5.2 - D25 All relevant information shall be distributed to appropriate personnel

Ensure that design and specification information is issued to site supervisors and relevant specialist subcontractors and/or suppliers.

## MATERIALS STANDARDS

### 5.2 - M1 All materials shall:

- (a) meet the Technical Requirements
- (b) take account of the design

Materials that comply with the design and the guidance below will be acceptable for suspended ground floors.

Materials for suspended ground floors should comply with all relevant standards, including those listed below. Where no standard exists, Technical Requirement R3 applies (see Chapter 1.1 'Introduction to the Standards and Technical Requirements').

References to British Standards and Codes of Practice include those made under the Construction Products Directive (89/106/EEC) and, in particular, appropriate European Technical Specifications approved by a European Committee for Standardisation (CEN).

# 5.2 Suspended ground floors

## CONCRETE AND REINFORCEMENT

**5.2 - M2 Concrete shall have appropriate reinforcement and be of a mix design that will:**

- (a) achieve sufficient strength to support floor loads safely
- (b) be sufficiently durable to remain unaffected by chemical or frost action

For guidance on the specification and use of in-situ concrete, additives and reinforcement, reference should be made to Chapter 2.1 'Concrete and its reinforcement' (each section).

## PROPRIETARY SYSTEMS

**5.2 - M3 Proprietary flooring systems shall have adequate strength and durability**

Proprietary concrete flooring systems should be designed in accordance with BS EN 1992-1-1. Where a system incorporates elements which cannot be designed to this standard, eg polystyrene infill blocks, the floor should be assessed in accordance with Technical Requirement R3.

## TIMBER

**5.2 - M4 Structural timber, decking and related materials shall be suitable for their location and intended use**

Materials should be selected in accordance with the relevant parts of Chapter 6.4 'Timber and concrete upper floors' (Design and Materials).

## DAMP-PROOFING AND THERMAL INSULATION MATERIALS

**5.2 - M5 Materials shall be suitable for their location and intended use**

Items to be taken into account include:

### (a) damp-proofing materials

Damp-proofing materials should be selected in accordance with Chapter 5.1 'Substructure and ground bearing floors' (Design and Materials).

### (b) thermal insulation materials

Thermal insulating materials used below cast in-situ suspended floor slabs should be selected in accordance with the relevant recommendations given in Chapter 5.1 'Substructure and ground bearing floors' (each section).

Thermal insulating materials for use with timber floors should be:

- expanded polystyrene boards (grade EPS 70) to BS EN 13163
- mineral wool to BS 5803 : Part 1
- other materials which have been assessed in accordance with Technical Requirement R3.

For thermal insulation used above concrete floor slabs, materials should be selected in accordance with Chapter 8.3 'Floor finishes' (Design and Materials).

## SITWORK STANDARDS

**5.2 - S1 All sitework shall:**

- (a) meet the Technical Requirements
- (b) take account of the design
- (c) follow established good practice and workmanship

Sitework that complies with the design and the guidance below will be acceptable for suspended ground floors.

## VENTILATION AND DAMP-PROOFING

**5.2 - S2 Construction of suspended ground floors shall ensure adequate damp-proofing**

Masonry supporting suspended ground floors should have been damp-proofed using dpm, dpc or tanking in accordance with the guidance given in the following Chapters:

5.1 'Substructure and ground bearing floors' (each section)

6.1 'External masonry walls' (each section).

Where proprietary floor systems are used, moisture-resistant membranes, etc should be installed in accordance with the manufacturer's recommendations.

**5.2 - S3 Construction of suspended ground floors shall ensure adequate ventilation**

Ventilation should be provided in accordance with the design. This is normally provided by ventilators on at least two opposite external walls.

Air bricks in cavity walls should be properly ducted as detailed in Chapter 6.1 'External masonry walls' (Design and Sitework).

Sleeper walls should be constructed with sufficient openings to ensure adequate through ventilation. Where underfloor voids adjoin ground bearing floors, ventilation ducts should be installed.

Ventilation should not be obtained through a garage.

## CONSTRUCTION OF FLOORS

**5.2 - S4 Construction of suspended floors shall ensure that they safely support the intended loads and are reasonably level**

Items to be taken into account include:

### (a) in-situ concrete floors

Concreting should be carried out in accordance with:

- the design
- relevant parts of Chapter 2.1 'Concrete and its reinforcement' (each section)
- relevant parts of Chapter 6.4 'Timber and concrete upper floors' (each section).

### (b) precast concrete floors

All sitework for precast concrete floors should be carried out in accordance with the manufacturer's recommendations.

Care should be taken to ensure that dpcs are not damaged or displaced.

### (c) timber floors

All sitework for timber floors should be carried out in accordance with the relevant parts of Chapter 6.4 'Timber and concrete upper floors' (Sitework).

## THERMAL INSULATION

**5.2 - S5 Thermal insulation shall be installed to minimise thermal transmission through the floor**

The BRE report 'Thermal insulation: avoiding risks' discusses aspects of insulation relevant to suspended ground floors. In England and Wales account should be taken of Accredited Details.

Items to be taken into account include:

### (a) floor insulation methods

#### TIMBER FLOORS

Insulation quilts should be supported, eg by draping plastic mesh across the joists and stapling it to joist sides so that the quilt can be laid to the full thickness. Insulation draped over the joists is not acceptable.

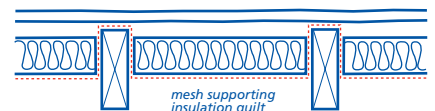

Rigid insulation boards should be supported on battens or fillets nailed to the sides of joists.

#### CONCRETE FLOORS

For guidance on insulating concrete floors, reference should be made to Chapter 8.3 'Floor finishes' (each section).

### (b) cold bridging

The design should be followed to ensure that any risk of cold bridging is minimised. Pay particular attention to junctions between floor and external walls.

## FLOOR FINISHES

**5.2 - S6 Finishes to concrete suspended ground floors shall be protected, where necessary, against damp, condensation or spillage**

For guidance, reference should be made to Chapter 8.3 'Floor finishes' (Design and Sitework).



## FLOOR DECKING : GENERAL

### 5.2 - S7 Flooring shall be fixed only when the dwelling is substantially weathertight

For guidance, reference should be made to Chapter 6.4 'Timber and concrete upper floors' (Sitework).

### 5.2 - S8 Completed floor decking shall not be overloaded and shall be protected against damage

For guidance, reference should be made to Chapter 6.4 'Timber and concrete upper floors' (Sitework).

Care should be taken to prevent trapping any water spillage below timber floors.

## SOFTWOOD BOARDING

### 5.2 - S9 Softwood boarding shall be securely fixed

For guidance, reference should be made to Chapter 6.4 'Timber and concrete upper floors' (Design and Sitework).

## CHIPBOARD FLOORING

### 5.2 - S10 Chipboard flooring shall be of the type and thickness specified and shall be fixed securely

For guidance, reference should be made to Chapter 6.4 'Timber and concrete upper floors' (each section).

## ORIENTED STRAND BOARD FLOORING

### 5.2 - S11 Oriented strand board flooring shall be of the type and thickness specified and shall be fixed securely

For guidance, reference should be made to Chapter 6.4 'Timber and concrete upper floors' (each section).

## OTHER FLOOR DECKING

### 5.2 - S12 Plywood decking shall be fixed securely

For guidance, reference should be made to Chapter 6.4 'Timber and concrete upper floors' (Design and Sitework).

### 5.2 - S13 Proprietary materials shall be fixed in accordance with manufacturers' recommendations

Other floor decking should have been assessed in accordance with Technical Requirement R3 and should be installed in accordance with manufacturers' recommendations.

## INDEX

<b>B</b>		<b>O</b>	
Bearings	1, 2	Oriented strand board	5
Boarding	5	<b>P</b>	
<b>C</b>		Plywood	5
Chipboard flooring	5	Precast concrete	1, 4
Cold bridging	1, 2, 3, 4	Proprietary systems	4
Concrete	4	Protection	4
Concrete floors	4	Provision of information	3
<b>D</b>		<b>R</b>	
Damp-proofing	1, 2, 3, 4	Radon gas	1
Decking	1, 2, 5	Reinforcement	4
<b>E</b>		Resistance to moisture	1, 2
End bearings	1	<b>S</b>	
<b>F</b>		Separating walls	2
Floor decking	3, 5	Sleeper walls	2
Floor finishes	1, 2, 4	Softwood boarding	5
Floor slab	1, 2	Structural stability	2
<b>G</b>		Strutting	2
Ground contaminants	1	<b>T</b>	
<b>I</b>		Thermal insulation	1, 2, 3, 4
In situ concrete	1, 4	Timber	2, 4
Insulation	1, 2, 3, 4	Timber floors	4
Intermediate support	2	Trimmers	2
<b>J</b>		<b>U</b>	
Joist hangers	2	Underfloor voids	2, 3
<b>L</b>		<b>V</b>	
Loads	1	Ventilation	2, 3, 4
		Void	2, 3



# Chapter 5.3

## Drainage below ground

---



# 5.3 Drainage below ground

## CONTENTS

	Clause	Page
<b>DESIGN</b>		
Design standards	D1	1
Statutory requirements	D2	1
Drainage system design	D3-D6	1 - 2
Design to avoid damage	D7	2
Foul and surface water disposal	D8	3
Ground water drainage	D9	4
Provision of information	D10-D11	4
<b>MATERIALS</b>		
Materials standards	M1	4
Drainage materials	M2	4
<b>SITWORK</b>		
Sitework standards	S1	5
Preliminary work	S2	5
Excavation	S3	5
Laying pipework	S4	5
Protection of pipework	S5	6
Access points and gullies	S6	6
Cesspools	S7	7
Septic tanks	S8	7
Surface water soakaways	S9	7
Testing	S10	8
Protection of work	S11	8
<b>APPENDIX 5.3-A</b>		
Minimum dimensions for access fittings and chambers		9
<b>APPENDIX 5.3-B</b>		
Percolation test procedures for septic tank installations		10
<b>APPENDIX 5.3-C</b>		
Septic tank field drain design		11
<b>APPENDIX 5.3-D</b>		
Cross section of typical underdrain		12
<b>APPENDIX 5.3-E</b>		
Percolation test procedures for surface water soakaways		12
<b>INDEX</b>		14

## SCOPE

This Chapter gives guidance on meeting the Technical Requirements and recommendations for the design and the construction of foul, surface water and ground water drainage systems.



## DESIGN STANDARDS

### 5.3 - D1 Design shall meet the Technical Requirements

Design that follows the guidance below will be acceptable for drainage below ground.

## STATUTORY REQUIREMENTS

### 5.3 - D2 Design shall comply with all relevant statutory requirements

Design should be in accordance with relevant Building Regulations and other statutory requirements.

All drainage schemes require the approval of the Building Control Authority. Local sewerage undertakers may impose additional requirements and restrictions. Both should be consulted early, especially where the drainage system is to be adopted under an agreement under Section 104 of the Water Industry Act 1991 or Sewerage (Scotland) Act 1968. The system may need to be inspected and tested by the sewerage undertaker, as well as by the Local Authority, Building Control Authority and NHBC.

Sewers which are to be adopted under an agreement under Section 104 of the Water Industry Act 1991 or Sewerage (Scotland) Act 1968 are outside the scope of this document. For information on standards required for adopted sewers, contact the local sewerage undertaker and other relevant Authorities.

Satisfactory outfall disposal is essential where a septic tank is installed. In England and Wales the Environment Agency consent may be needed to discharge effluent from a septic tank. In Northern Ireland the Department of the Environment should approve proposals, in Scotland the Local Authority and, where appropriate, the River Purification Authority should approve proposals.

Ground conditions may preclude the use of septic tanks in some locations. In all cases NHBC will require evidence of a satisfactory percolation test where a septic tank drainage system is being installed. See Appendix 5.3-B.

For surface water discharge into a watercourse the permission of the Environment Agency is required in England and Wales. A "consent to discharge" is required from the DoE in Northern Ireland. In Scotland the Local Authority and, where appropriate, the River Purification Authorities should be consulted.

## DRAINAGE SYSTEM DESIGN

### 5.3 - D3 Drainage systems shall be designed to convey foul effluents and surface water satisfactorily to an appropriate outfall

Items to be taken into account include:

**(a) compliance with codes and standards**  
Guidance on drainage design is given in BS EN 752.

**(b) compatibility with the existing main sewerage system**

The drainage system should be designed to be compatible with the main sewerage system:

- as a combined system, or
- with separate systems for foul water and surface water, or
- with separate systems where foul water is connected to the main sewer, while surface water disposal is by soakaways or other suitable means.

Where the sewerage undertaker permits surface water drains to be connected to a foul water system an interceptor should be installed on the surface water side of the foul sewer junction, or trapped gullies should be used.

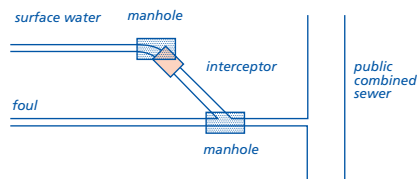

Where ground water drains are connected to surface water drains, there should be a silt trap on the ground water side of the junction.

**(c) rights of connection to disposal systems**

Ensure that a legal right exists when connecting drains to an outfall.

**(d) capacity of private sewers**

Private drainage systems should be sufficient to cope with the intended capacity. The design should be in accordance with BS EN 752 or similar authoritative document.

Where an existing private drainage system is to be extended, or where the capacity is to be increased, sufficient investigation, measurement and calculation should be undertaken to ensure that all parts of the private system are of adequate capacity.

### 5.3 - D4 Drainage shall be designed to prevent health hazards

Items to be taken into account include:

**(a) ventilation of systems**

Ventilation of drains is normally achieved by ventilating discharge stacks. For details, reference should be made to Chapter 8.1 'Internal services' (Design).

Air admittance valves which have been assessed in accordance with Technical Requirement R3 may be used in some dwellings to prevent trap seal siphonage. An open vent is generally required at the head of common drainage systems and where the discharge pipe is the only vent for a septic tank or cesspool.

**(b) prevention of gases entering the dwelling**

**RADON**

In certain geographical locations special precautions may be necessary to reduce the entry of radon gas, for example where drains enter buildings. Areas in England where special precautions are necessary are detailed in BRE Report 211.

**LANDFILL AND OTHER GASES**

Precautions to be taken when building where landfill or other gases may be present are given in BRE Report 212.

Where necessary ensure that drains are sealed where they enter the building.

**(c) siting of septic tanks and cesspools**

Septic tanks and cesspools should be at least 7m from a dwelling and within 30m of a vehicular access to permit emptying. In Scotland they should be at least 5m from a dwelling and a boundary.

**(d) pumped systems**

Where a gravity system is not possible, pumps may have to be used. Pumped systems should be designed in accordance with BS EN 752 and BS 6297. The installation should include:

- holding tank of sufficient volume to contain 24 hours domestic effluent based on 120L/150L per head per day
- suitable warning system giving visual and/or audible signals to indicate system malfunction
- suitable equipment housing.

### 5.3 - D5 Drainage systems shall be designed to minimise the risk of blockage

Items to be taken into account include:

**(a) pipe sizes**

Pipe sizes should be designed for the maximum peak load, using BS EN 752 as the basis for calculations. Ground water drains and soakaways should be designed with sufficient capacity for normal weather conditions.

**(b) gradients**

Design gradients should be as even as practicable, depending on the number of WCs being served (minimum one for 100mm pipes, five for 150mm pipes, with peak flows greater than 1 L/sec. at the gradients shown below).

Where flows are 1.0 L/second or less, gradients for 100mm diameter pipes should not be flatter than 1:40.

# 5.3 Drainage below ground

The following gradients may be used where flows exceed 1.0L/second:

Pipe diameter [mm]	Minimum gradient
100	1 : 80
150	1 : 150

### (c) pipe runs

Pipe runs should be designed to maintain self-cleansing velocity (0.7 m/s). They should be as straight as practicable with minimal changes of direction. Bends should only occur in or next to inspection chambers or manholes. Curves should be slight so that blocked pipes can be cleared.

### (d) access

To ensure that every length of drain can be rodded, the design should include all necessary access points, such as:

- rodding eyes
- access chambers
- inspection chambers
- manholes.

Sizes of access fittings and chambers should be specified for the depth of invert as detailed in Appendix 5.3-A.

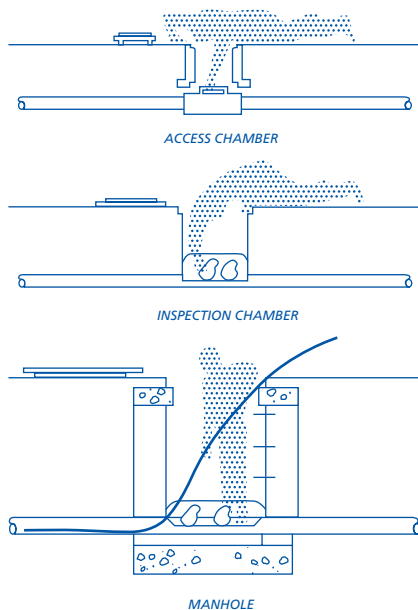

Inspection chambers and manholes may be the following types:

- open, half-round section channel with suitable benching, or
- closed access - at manholes, cover panels have to be removed to gain access to the pipe.

Side branches to inspection chambers and manholes should discharge into the main channel not higher than half pipe level.

Connections should be made obliquely in the direction of flow.

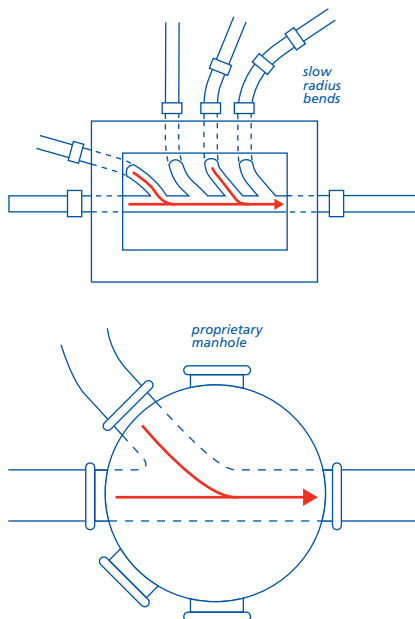

For construction details of access fittings and chambers, reference should be made to clause S6.

### 5.3 - D6 Foul and surface water drainage systems shall be adequately watertight under test and working conditions

Items to be taken into account include:

#### (a) ground movement

All pipes should have flexible joints.

Where ground movement may occur, precautions against leakage are needed. In mining areas, and in other locations where movement could be significant, a flexible pipe system should be specified. Flexible systems should be flexible pipes with flexible joints. Refer to Sitework Clause S5.

Proper allowance should be made for settlement. Where there is a risk of soil movement, for example in made-up ground, design gradients should be steeper than the minimum allowed for the flow rate and pipe size.

In non-uniform or saturated soils where movements of the trench bottom can be expected, soft spots should be removed and replaced with suitable material. Protective blinding should be specified for the trench bottom, to be placed immediately following excavation.

In ground conditions where movement is likely to adversely affect the drain a support system for the drain should be designed by an Engineer in accordance with Technical Requirement R5.

Shrinkage and heave of clay soils can affect pipelines. Design gradients should be greater than the permitted minimum to allow for possible movement. Refer to Chapter 4.2 'Building near trees' for details of zones of influence of trees.

### (b) flooding

Where there is a risk of flooding the advice of the relevant Rivers Authority should be followed.

### (c) ground water

Foul and surface water drainage systems should prevent the ingress of ground water.

## DESIGN TO AVOID DAMAGE

### 5.3 - D7 Drainage systems shall be designed so that they are adequately protected against damage

Items to be taken into account include:

#### (a) loads from foundations

Drains should be located so that foundation loads are not transmitted to pipes. Where drainage trenches are near foundations, foundation depths should be increased or the drain re-routed further from the foundations.

Where the bottom of a trench is below foundation level, the trench should be filled with concrete to a suitable level.

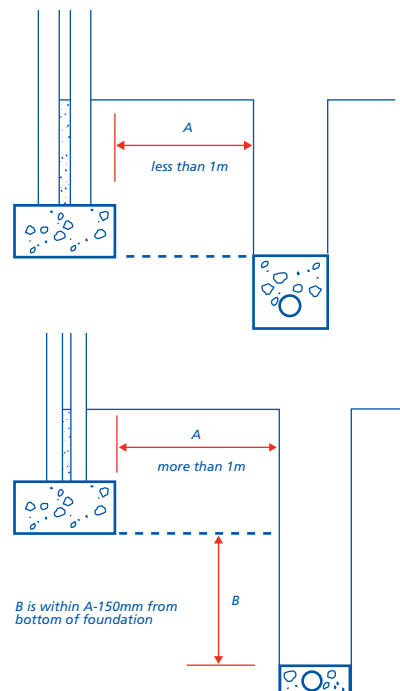

Where drains pass through structural elements, allowance should be made for differential movement, thermal movement and maintenance.

Pipes passing through substructure walls should accommodate movement by:

- 50mm clearance all round, or
- a sleeve with a 50mm clearance, or
- if built in, a connection on both sides of the wall to pipes with flexible joints located not more than 150mm from the face of the wall. Refer to Sitework clause S5(a).

See clause D4(b) for prevention of gas entering the building.

## (b) loads from overlying fill and traffic

Pipes should be firmly supported throughout their length and bedded to resist loads from overlying fill and traffic. Small diameter rigid pipes may be laid:

- directly on trench bottoms, or
- bedded on granular material. Refer to Sitework clause S4.

For flexible pipes, and where a greater factor of safety is needed, specify the bedding class and grading of backfill as described in BS EN 13242, BS 5955 and BS EN 752. Refer to Sitework clause S4(a).

When using proprietary systems assessed in accordance with Technical Requirement R3, pipes should be supported in accordance with the assessment.

Special protection may be required where pipes are near the ground surface or where they could be damaged by the weight of backfill or traffic load from above. Guidance is given in Sitework clause S5 and in BS 5955 and BS EN 752.

Manhole covers, gully gratings and other fittings should be suitable for the traffic conditions.

## (c) chemicals in ground and ground water

If the ground or ground water contains sulfates, concrete and masonry work may require special precautions as detailed in Chapters 2.1 'Concrete and its reinforcement' (Design) and 6.1 'External masonry walls' (Design).

## FOUL AND SURFACE WATER DISPOSAL

### 5.3 - D8 Drainage systems shall be designed to connect to a suitable outfall

Items to be taken into account include:

#### (a) connection to a main foul sewer

All connections to a public sewer will require the agreement of the responsible authority. They should be consulted as to the type and position of the connection to be made.

All connections to a private sewer will require the agreement of the owners of the sewer. This should be obtained as part of the design process. If the main private sewer discharges into a public sewer the local sewerage undertaker should be notified of the proposal.

#### (b) connection to a cesspool or a septic tank

The entry flow velocity should be restricted to reduce disturbance in the tank. For drains not exceeding 150mm diameter a gradient not steeper than 1:50 for a distance of at least 12m upstream of the entry is required.

Rodding and cleaning facilities should be provided at the connection with the tank.

## (c) connection to surface water disposal systems

Surface water drainage is generally required to be separated from foul water drainage. Surface water may be discharged into public surface water main drains or directly into natural watercourses, ponds or soakaways, as appropriate. Surface water should not discharge to a septic tank or cesspool, or a separate foul sewer.

For large or complicated dwellings the amount of surface water to be disposed of may be calculated by reference to BS 6367.

Siting of soakaways should take account of topography to ensure that water is drained away from the building. In soil of low permeability, soakaways should only be provided where no alternative system is available. Soakaways should be a minimum of 5m from any adjacent building.

A simple test for assessing the permeability of the soil and how to convert the result into soakaway dimensions is detailed in Appendix 5.3-E. A more refined method to determine soakaway size is given in BRE Digest 365.

## (d) cesspools

A cesspool is a tank which stores effluent and has to be emptied periodically.

Cesspools should be sited within 30m of a vehicle access to permit emptying. They should be at least 7m from a dwelling.

Cesspools are required to be at least 18m<sup>3</sup> capacity. A 45 day holding capacity calculated at 150 litres/head/day should be provided.

## (e) septic tanks

A septic tank is a form of treatment plant and requires a suitable outfall (agreed by the relevant authority) for treated effluent discharge. Septic tank design is detailed in BS 6297.

Septic tanks should be sited within 30m of a vehicle access to permit emptying. They should be at least 7m from a dwelling. In Scotland they should be at least 5m from a dwelling and a boundary.

## CAPACITY

The capacity of the septic tank should be based on the number of people it will serve. This is determined by the formula:

$$C = 180P + 2000$$

where C = capacity of tank (in litres) min 2700L

and

P = design population/potential occupancy (min 4)

Appendix 5.3-C gives minimum capacities for septic tanks serving up to 10 persons.

## OUTFALL

The outfall from a septic tank may require consent from the Environment Agency in England and Wales. In Northern Ireland the Environment and Heritage Service should approve proposals. In Scotland the Scottish Environment Protection Agency should approve proposals. The designer should ensure at an early stage that consent will be given, or an alternative method of drainage selected.

Copies of relevant consents are required by NHBC before work commences.

## POROUS SUBSOILS

If the outfall from a septic tank is to discharge to a porous subsoil, such as gravel, sand or chalk, at a level above that of the winter water table level, a soakaway may be used.

This consists of an excavation filled with brick bats or other large pieces of inert material; or unfilled but lined, eg with dry laid brickwork or precast concrete (porous or perforated) rings, from which the effluent may percolate into the surrounding ground. Soakaways which are not filled should be covered by a slab incorporating an inspection cover.

The size of the soakaway should be determined as described in Appendix 5.3-C, the area of the bottom of the soakaway should equal the area of trench bottom in Chart 1.

Where the porous strata is overlaid by less permeable sub soil a bore hole may be permitted by the appropriate authority.

Proprietary septic tanks should be assessed in accordance with Technical Requirement R3.

## LESS POROUS SUBSOILS

In less porous subsoils a sub surface irrigation system may be a possible alternative.

Such an alternative will have to be designed to determine the area of the sub surface drainage trench from which the length of land drain can be found.

First a percolation test has to be carried out to determine the percolation value (s) in seconds. Details of how to carry out the test are given in Appendix 5.3-B.

If the percolation value is less than 100s use Chart 1 to determine the field drain trench area and Chart 2 the pipe length to provide this area. For percolation values between 100s and 140s underdrains are necessary. For percolation values in excess of 140s the soil is unsuitable for field drains.

Design guidance for underdrains is given in Appendix 5.3-D.

# 5.3 Drainage below ground

## FIELD DRAINS

These should be:

- sited taking account of topography to ensure that water is drained away from the building
- perforated pipes laid at least 500mm below the surface
- laid in trenches with a uniform gradient not steeper than 1:200 with undisturbed ground 2m wide between trenches and at least 8m from any building and 10m from any water course
- laid on a 150mm bed of clinker, clean gravel or broken stone (20 - 50mm grade) and the trenches filled to a level 50mm above the pipe and covered with strips of plastic material to prevent entry of silt
- backfilled with as dug material.

Note. If the level of the water table is expected to rise in the winter months to within 1m of the invert of the field drains, it is not acceptable to use sub-surface irrigation.

### (f) small private sewage treatment works for more than one dwelling

Small sewage treatment works for more than one dwelling should be designed in accordance with BS 6297. The discharge from the waste water treatment plant should be sited at least 10m away from water courses and dwellings. The design should be carried out by a suitably qualified engineer.

## GROUND WATER DRAINAGE

**5.3 - D9 Ground water drainage shall be designed to convey excess ground water to a suitable outfall**

### (a) layout of pipes

Depending on site contours and ground conditions, ground water drainage, where required, may be designed as a:

- natural system
- herringbone system
- grid system
- fan-shaped system
- moat system.

### (b) pipe construction

Pipe perforations should be holes or slots to suit the nature of the ground.

### (c) outfall

Ground water drain systems connected to foul, surface water or combined drains should discharge into the drain through a catchpit. Where available, ground water drainage may discharge into a soakaway, preferably through a catchpit or into a watercourse.

In England and Wales the National Rivers Authority consent may be needed for discharge proposals. In Northern Ireland the Department of Environment should approve proposals; in Scotland the River Purification Authority should approve proposals.

## PROVISION OF INFORMATION

**5.3 - D10 Designs and specifications shall be produced in a clearly understandable format and include all relevant information**

Drawings and specifications should include:

- proposed drain layout
- invert levels and locations of existing sewers
- junctions
- ground floor levels of dwellings
- external finished levels
- inspection and access points
- method of disposal of both foul and surface water
- position of any septic tank or cesspool in relation to adjacent buildings
- results of percolation tests where treated effluent disposal is through field drains
- length of field drains and their layout (including details of trench width, this being critical to the functioning of the system)
- depth of field drains.

Drains or sewers which are intended for adoption should be clearly identified on relevant drawings.

**5.3 - D11 All relevant information shall be distributed to appropriate personnel**

Ensure that design and specification information is distributed to site supervisors, relevant specialist subcontractors and/or suppliers.

## MATERIALS STANDARDS

**5.3 - M1 All materials shall:**

- (a) meet the Technical Requirements**
- (b) take account of the design**

Materials that comply with the design and the guidance below will be acceptable for drainage below ground.

Materials for drainage below ground should comply with relevant standards, including those listed below. Where no standard exists, materials should carry a certificate of assessment from an independent authority, acceptable to NHBC. Materials of a higher standard are also acceptable.

References to British Standards and Codes of Practice include those made under the Construction Products Directive (89/106/EEC) and, in particular, appropriate European Technical Specifications approved by a European Committee for Standardisation (CEN).

## DRAINAGE MATERIALS

**5.3 - M2 All materials for drainage work shall ensure satisfactory service for the life of the system**

Items to be taken into account include:

### (a) manholes, chambers, pipes, fittings and covers

BS 65	Specification for vitrified clay pipes, fittings, joints and ducts (Note: This includes perforated pipes)
BS 437	Specification for cast iron spigot and socket drainpipes and fittings
BS 1247	Specification for manhole step irons
BS EN 588	Fibre cement pipes for sewers and drains.
BS 4660	Specification for unplasticised PVC underground drain pipes and fittings
BS 4962	Specification for plastics pipes for use as light duty sub-soil drains
BS 5911	Precast concrete pipes, fittings and ancillary products
BS 5955	Plastics pipework (thermoplastic materials)
BS 6087	Specification for flexible joints for cast iron drainpipes and fittings (BS 437) and for cast iron soil, waste and ventilating pipes and fittings (BS 416)
BS DD 76	Draft for Development, Precast concrete pipes of composite construction
BS EN 124	Gully tops and manhole tops for vehicular and pedestrian areas
BS EN 295	Vitrified clay pipes and fittings and pipe joints for drains and sewers
BS EN 1401-1	Plastics piping systems for non-pressure underground drainage and sewerage - Unplasticised poly (vinyl chloride) (PVC-U)

### INSPECTION/MANHOLE COVERS AND FRAMES

- Group 1 - Areas which can only be used by pedestrians and pedal cyclists.
- Group 2 - Footways, pedestrian areas and comparable areas, car parks or car parking decks.
- Group 3 - For gully tops installed in the area of kerbside channels of roads which when measured from the kerb edge, extend a maximum of 0.5m into the carriageway and a maximum of 0.2m into the footway.
- Group 4 - Carriageways of roads (including pedestrian streets), hard shoulders and parking areas, for all types of road vehicles.

Covers used for manholes within buildings should be airtight and mechanically secured.

Covers used for septic tanks, cesspits and settlement tanks should be lockable.



### GULLY GRIDS

- Grade B - for use in carriageways of roads with cars and slow moving normal commercial vehicles
- Grade A Class 2 - for use in carriageways of roads
- Grade A Class 1 - for use in carriageways of roads (gully grids of permanent non-rock design).

### (b) bricks and blocks

Clay bricks for manholes should comply with BS EN 771 and:

- be of low active soluble salt content
- have a compressive strength not less than 48N/mm<sup>2</sup>.

Engineering bricks are suitable.

Concrete bricks to BS EN 771 should have a minimum crushing strength of 48N/mm<sup>2</sup> with a minimum cement content of 350kg/m<sup>3</sup> for foul drainage.

Calcium silicate bricks should comprise strength class 20 or above for foul drainage situations.

### (c) backfill and bedding

Granular backfill and bedding material should comply with the requirements of BS EN 13242, BS 5955 and BS EN 752, as specified.

Rigid pipes of nominal size 100mm and 110mm nominal flexible pipes should have granular material bedding to BS EN 13242 of 4/10mm pipe bedding gravel. Rigid pipes of nominal size 150mm and 160mm nominal flexible pipes should have granular material bedding to BS EN 13242 of 2/14mm pipe bedding gravel. See Sitework clause S4 (a).

Proprietary pipe systems should be supported and bedded in accordance with the manufacturer's recommendations.

## SITWORK STANDARDS

### 5.3 - S1 All sitework shall:

- (a) meet the Technical Requirements
- (b) take account of the design
- (c) follow established good practice and workmanship

Sitework that complies with the design and the guidance below will be acceptable for drainage below ground.

## PRELIMINARY WORK

### 5.3 - S2 Checks shall be made on site to ensure that the design can be achieved

Check that the following are as specified in the design:

- invert levels and locations of existing sewers
- ground floor levels of dwellings
- external finished levels.

Percolation tests should be verified where treated effluent disposal is through field drains.

The length of any field drains specified in the design should be accommodated within the site boundaries.

## EXCAVATION

### 5.3 - S3 Excavation shall ensure that the invert levels and gradients required by the design are achieved

Items to be taken into account include:

#### (a) setting out dimensions

Drain runs and depths should be set out from benchmarks previously checked and verified. Any discrepancies in dimensions, and any ground conditions requiring modification to the design, should be reported immediately. Any resulting variations should be recorded and distributed to all concerned.

#### (b) depth of trenches

Excavate to the depths shown on the drawings. If any trench is excavated lower than the designed bottom level, it should be re-filled to the designed level to allow for the bedding to be continuous. Fill material should be:

- granular material, or
- concrete mix GEN 1 or ST 1/2 (not for field drains).

Hard spots should be undercut and removed, so that local stress points under pipes are avoided.

Soft spots should be filled with suitable well-compacted material.

#### (c) width of trenches

Trenches should be as narrow as possible within working limits, allowing at least 150mm working space on each side of the pipe.

#### (d) proximity of foundations

Foundation bottoms should be lower than adjacent drainage trenches.

Where the bottom of a trench is below foundation level, the trench should be filled with concrete to a suitable level.

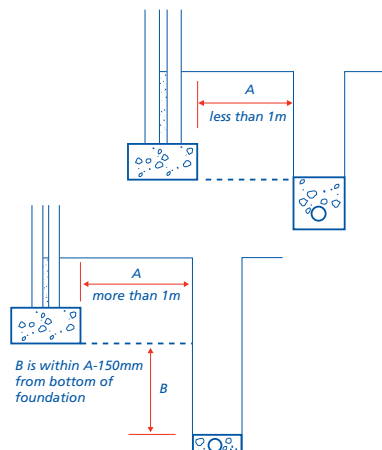

## LAYING PIPEWORK

### 5.3 - S4 Pipework shall be laid to the designed lines and gradients

Items to be taken into account include:

#### (a) bedding

Pipes should be firmly supported throughout their length and bedded as specified in the design.

Bricks, blocks or other hard material should not be used as temporary supports to achieve the correct gradients, as they may create hard spots which can distort the completed pipe run.

Pipes should be either:

- bedded on granular material, minimum 100mm deep or
- laid directly on the trench bottom, where the trench bottom can be accurately hand trimmed with a shovel but is not so soft that it puddles when walked on.

Depressions should be formed where necessary in the trench bottom to accommodate pipe joints.

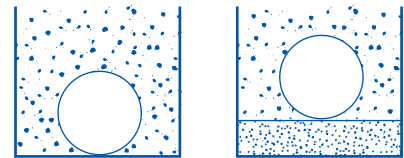

Nominal pipe size [mm]		Granular material for bedding
rigid pipes	flexible pipes	Material (complying with BS EN 13242)
100	110	4/10mm pipe bedding gravel
150	160	2/14mm pipe bedding gravel or 4/10mm pipe bedding gravel

Proprietary pipes should be supported in accordance with manufacturers' recommendations. Some proprietary systems permit a minimum of 50mm depth of bedding in certain circumstances. Generally, for 150mm diameter and 100mm diameter drains, a bed and surround of 10mm pea gravel (to a thickness of 100mm all round the drain) will be acceptable for drains under gardens, paths and drives.

#### (b) jointing

Pipes should have flexible joints, installed in accordance with manufacturers' recommendations.

#### (c) sidefill and backfill

Sidefill and backfill should be placed as soon as the pipes have been bedded, jointed and inspected.

For proprietary systems, sidefilling and backfilling should be carried out

# 5.3 Drainage below ground

in accordance with manufacturers' recommendations. Sidefill should be either:

- granular material (see table to Clause S4(a)), or
- selected backfill material from the trench excavation, ie free from:
  - stones larger than 40mm
  - clay lumps larger than 100mm
  - timber
  - frozen material
  - vegetable matter.

## GENERAL BACKFILL

Normally the excavated material from the trench will be suitable for backfilling above the selected material. General backfill material should be free from:

- boulders
- building rubble
- timber
- vegetable matter.

## PLACING BACKFILL

Backfill should be placed in layers not deeper than 300mm, and should be well compacted. Mechanical compacting should only be used when compacted backfill is at least 450mm above the crown of the pipe.

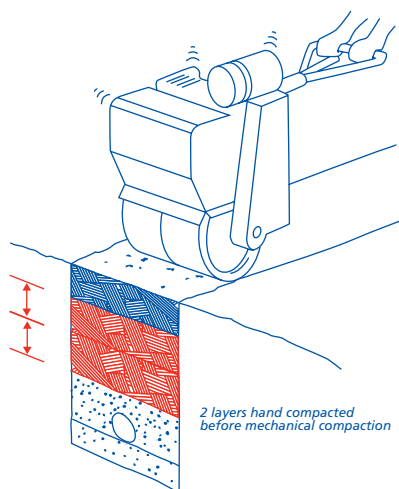
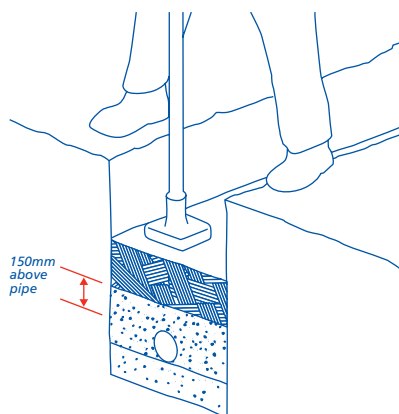

## PROTECTION OF PIPEWORK

### 5.3 - S5 Pipework shall be adequately protected against damage

Items to be taken into account include:

#### (a) pipes passing through substructure walls

Pipes passing through substructure walls should accommodate movement. This may be achieved by:

- a 50mm clearance all round, or
- a sleeve, with 50mm clearance all round and suitably sealed
- if built in, connecting on both sides of the wall to pipes with flexible joints located not more than 150mm from the face of the wall. Flexible joints should be made in accordance with the pipe manufacturer's recommendations.

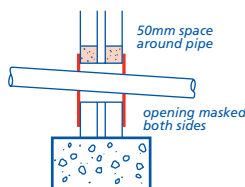

PIPES PASSING THROUGH LINTELLED OPENING

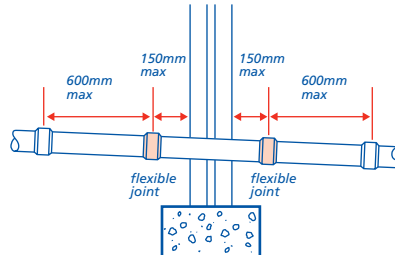

PIPES BEDDED IN WALLS

#### (b) pipework under roads

Where drains pass under roads and drives, the final compaction should be sufficient to prevent later settlement.

#### RIGID PIPES

Rigid pipes less than 1.2m below the road surface should, where necessary, be protected from damage by concrete encasement not less than 100mm thick, and having movement joints formed with compressible board at each socket or sleeve joint face.

Flexible joints should remain flexible.

#### FLEXIBLE PIPES

Flexible pipes less than 0.9m below the road surface should be protected by concrete bridging slabs or should be surrounded with concrete reinforced as appropriate.

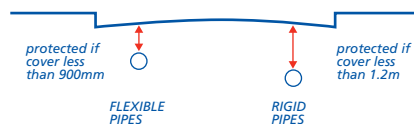

## GARDEN AREAS

Where flexible pipes are not under a road and have less than 0.6m cover they should, where necessary, have concrete paving slabs laid as bridging above the pipes, with at least 75mm of granular material between the top of the pipe and underside of the slabs.

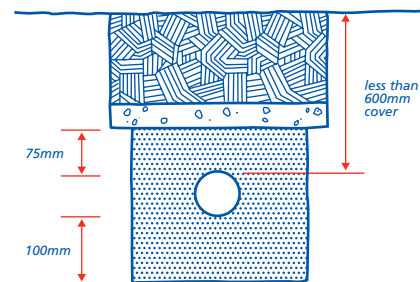

#### (c) movement joints

Where rigid pipes have to be encased in concrete, movement joints of 13mm thick compressible board should be provided around the spigot next to the socket, either at each joint or at not more than 5m intervals.

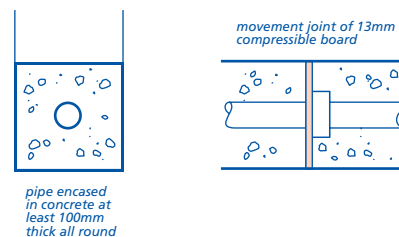

## ACCESS POINTS AND GULLIES

### 5.3 - S6 Access points shall be constructed and installed as required by the design

Items to be taken into account include:

#### (a) size and location of access points

All access points should be located where shown on the drawings. They should:

- be accessible for rodding and cleaning
- not cross boundaries or kerb lines.

Ensure that inspection chambers and manholes are of sufficient size for the depth of invert. Do not exceed the invert depth for the particular fitting or chamber. Reference should be made to Appendix 5.3-A.

#### (b) covers of the drainage system

Manholes should be constructed or installed at the correct level, so that the covers will align with the adjacent ground. Gullies should be adequately bedded, set level and square and kerbed, where necessary.

#### (c) traditional construction

The minimum specification for traditional manholes and inspection chambers is as follows:

## BASE

Concrete not less than 100mm thick.

## WALLS

Brick, blockwork or concrete should be appropriate for ground conditions. Generally 100mm minimum thickness is suitable for depths up to 0.9m where no vehicular traffic loads are encountered and there is no ground water pressure. Elsewhere, 200mm minimum thickness should be provided.

## RENDERING

Rendering, if required, should be applied to the external faces of the wall.

## BENCHING

Benching should be steel trowelled to provide:

- a smooth finish
- rounded corners
- a fall of not less than 1:12
- a good foothold.

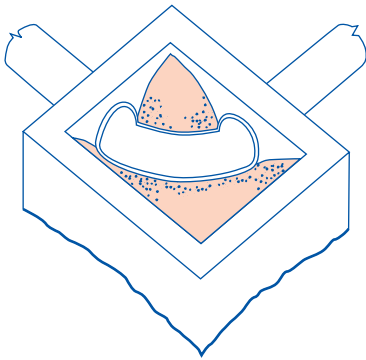

## (d) proprietary systems

Proprietary systems should be installed strictly in accordance with manufacturers' instructions. Adaptors, couplers and sealing rings should be installed correctly and only the lubricants and solvents specified by the manufacturer used.

Proprietary manholes should not be used at a depth greater than that for which they have been assessed as suitable.

## (e) type of cover/grid

Manhole covers and gully grids should be of the correct type for the proposed location. Proprietary items (eg covers to plastic manholes) should be in accordance with manufacturers' recommendations.

## INSPECTION/MANHOLE COVERS AND FRAMES

- Group 1 - Areas which can only be used by pedestrians and pedal cyclists
- Group 2 - Footways, pedestrian areas and comparable areas, car parks or car parking decks
- Group 3 - For gully tops installed in the area of kerbside channels of roads which when measured from the kerb edge, extend a maximum of 0.5m into the carriageway and a maximum of 0.2m into the footway

- Group 4 - Carriageways of roads (including pedestrian streets), hard shoulders and parking areas, for all types of road vehicles.

Covers used for manholes within buildings should be airtight and mechanically secured.

Covers used for septic tanks, cesspits and settlement tanks should be lockable.

## CESSPOOLS

### 5.3 - S7 Cesspools shall be sited and constructed to prevent contamination of water and health hazards

Items to be taken into account include:

#### (a) resistance to the passage of water

Cesspools should be impermeable to their contents and to subsoil water. They may be constructed of brickwork, concrete, glass reinforced concrete, glass reinforced plastics or steel.

Brickwork should be of engineering bricks, laid in cement mortar and at least 220mm nominal thickness.

In-situ concrete should be at least 150mm thick.

#### (b) cover and ventilation

Cesspools should be covered and ventilated.

#### (c) siting, access and inspection

Cesspools should be sited at least 7m from a dwelling, but within 30m of a vehicle access to facilitate emptying.

Cesspools should be provided with access for emptying or de-sludging and cleaning. All such access points should have no dimension less than 600mm and be provided with lockable covers.

The inlet of a cesspool should be provided with access for inspection.

Cesspools should have no openings except the inlet, the vent and the inspection access.

## SEPTIC TANKS

### 5.3 - S8 Septic tanks shall be sited and constructed to prevent contamination of water and health hazards

Items to be taken into account include:

#### (a) outfall disposal

Satisfactory outfall disposal is essential where septic tank sewage disposal is installed. Environment Agency consent may be needed in England and Wales. In Northern Ireland the Environment and Heritage Service should approve proposals, in Scotland the Scottish Environment Protection Agency should approve proposals. Check that this approval has been obtained before starting drainage work.

Ground conditions may preclude the use of septic tanks in some locations. NHBC will require evidence of a satisfactory percolation test where a septic tank drainage system is to be installed. See Appendix 5.3-B.

Septic tanks should be sited taking account of topography to ensure that water is drained away from the building.

#### (b) impermeability to liquids

Septic tanks should be impermeable to their contents and to sub-soil water. They may be constructed of brickwork, concrete, glass reinforced concrete, glass reinforced plastics or steel.

Brickwork should be of engineering bricks, laid in cement mortar and at least 220mm thick.

In-situ concrete should be at least 150mm thick.

#### (c) cover and ventilation

Septic tanks should be covered and ventilated.

#### (d) siting, inspection and access

Septic tanks should be sited at least 7m from a dwelling, but within 30m of a vehicle access to facilitate emptying. In Scotland, they should be at least 5m from a dwelling and a boundary. Septic tanks should be provided with access for emptying or de-sludging and cleaning. All such access points where entry is required should have no dimension less than 600mm and be provided with lockable covers.

The inlet and outlet of a septic tank should be provided with access for inspection.

#### (e) velocity of flow

Provision should be made to limit the velocity of the flow to a septic tank. For drains up to 150mm diameter, the velocity may be limited by laying the last 12m of the incoming drain at a gradient not steeper than 1:50. A dip pipe should be provided, with the top limb rising above scum level and the bottom limb extending about 450mm below top water level.

## SURFACE WATER SOAKAWAYS

### 5.3 - S9 Soakaways shall be sited and constructed to provide adequate short term storage for surface water and adequate percolation into the surrounding ground

Items to be taken into account include:

#### (a) location

Where possible soakaways should be built on land lower than, or sloping away from, buildings. Soakaways should generally be sited at least 5m from the foundations of a building.

# 5.3 Drainage below ground

NHBC may require a percolation test for a soakaway. If the ground is free draining and granular, a test may not be necessary. However, if there is any doubt about the ground, or if there is a large quantity of run-off into the soakaway which may swamp the ground, a percolation test may be required.

Information on percolation tests is given in Appendix 5.3-E.

## (b) small soakaways

Small soakaways are holes filled with granular material, eg broken brick, crushed rock or gravel, with particle size 10mm to 150mm. PVC sheet or concrete blinding should be laid over the fill to prevent topsoil being washed down into the soakaway.

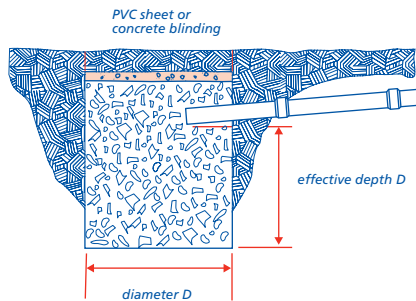

## (c) large soakaways

For large soakaways, a pit is lined with dry jointed or honeycomb brickwork.

Alternatively, perforated precast concrete rings or segments may be laid dry and surrounded with granular material.

The volume of large soakaways should be calculated to ensure they are of suitable capacity. Refer to Appendix 5.3-E or BRE Digest 365.

## TESTING

### 5.3 - S10 All foul and, where appropriate, surface water drainage systems shall be tested prior to handover

Inspection and testing should be arranged when required by the Local Authority, the sewerage undertaker and NHBC.

Before backfilling, visual inspections are required and the Builder is advised to test.

When the dwelling is handed over, the system must be in full working order and free from obstruction.

## PROTECTION OF WORK

### 5.3 - S11 All completed work shall be suitably protected from damage by construction work

Damaged drainage will not be accepted. It is recommended that no heavy loading or underground work is permitted above or near unprotected drainage, and that dumpers, trucks, fork lifts or other heavy vehicles are not driven along or near pipe runs.

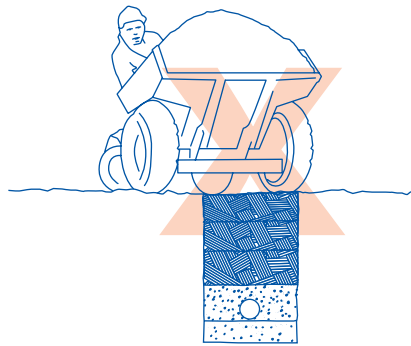



**APPENDIX 5.3-A**

Minimum dimensions for access fittings and chambers						
Type	Depth to invert from cover level (m)	Internal sizes		Cover sizes		
		Length x Width (mm x mm)	Circular (mm)	Length x Width (mm x mm)	Circular (mm)	
Rodding eye		As drain but min 100			Same size as pipework <sup>1</sup>	
Access fitting						
small	150 diam 150 x 100	0.6 or less, except where situated in a chamber	150 x 100	150	150 x 100 <sup>1</sup>	Same size as access fitting
large	225 x 100		225 x 100	225	225 x 100 <sup>1</sup>	
Inspection chamber						
shallow	0.6 or less 1.2 or less	225 x 100 450 x 450	190 <sup>2</sup> 450	- Min 430 x 430	190 <sup>1</sup> 430	
deep	greater than 1.2	450 x 450	450	max 300 x 300 <sup>3</sup>	Access restricted to max 350 <sup>3</sup>	

**Notes**

- The clear opening may be reduced by 20mm in order to provide proper support for the cover and frame.
- Drains up to 150mm.
- A larger clear opening cover may be used in conjunction with a restricted access. The size is restricted for health and safety reasons to deter entry.

Minimum dimensions for manholes					
Type	Size of largest pipe (DN) (mm)	Min internal dimensions <sup>1</sup>		Min clear opening size <sup>1</sup>	
		Rectangular length and width (mm)	Circular diameter (mm)	Rectangular length and width (mm)	Circular diameter (mm)
Manhole					
less than 1.5m deep to soffit	equal to or less than 150 225 300 greater than 300	750 x 675 <sup>7</sup> 1200 x 675 1200 x 750 1800 x (DN+450)	1000 <sup>7</sup> 1200 1200 1200 The larger of 1800 or (DN+450)	750 x 675 <sup>2</sup> 1200 x 675 <sup>2</sup>	na <sup>3</sup>
greater than 1.5m deep to soffit	equal to or less than 225 300 375 - 450 greater than 450	1200 x 1000 1200 x 1075 1350 x 1225 1800 x (DN+775)	1200 1200 1200 The larger of 1800 or (DN+775)	600 x 600	600
Manhole shaft <sup>4</sup>					
greater than 3.0m deep to soffit pipe	Steps <sup>5</sup>	1050 x 800	1050	600 x 600	600
	Ladder <sup>5</sup>	1200 x 800	1200		
	Winch <sup>6</sup>	900 x 800	900	600 x 600	600

**Notes**

- Larger sizes may be required for manholes on bends or where there are junctions.
- May be reduced to 600 by 600 where required by highway loading considerations, subject to a safe system of work being specified.
- Not applicable due to working space needed.
- Minimum height of chamber in shafted manhole 2m from benching to underside of reducing slab.
- Min clear space between ladder or steps and the opposite face of the shaft should be approximately 900mm.
- Winch only - no steps or ladders, permanent or removable.
- The minimum size of any manhole serving a sewer (i.e any drain serving more than one property) should be 1200mm x 675mm rectangular or 1200mm diameter.

Reproduced from Tables 11 and 12 of Approved Document H to the Building Regulations by permission of HMSO.

# 5.3 Drainage below ground

## APPENDIX 5.3-B

### Percolation test procedure for septic tank installations

- 1 Excavate a hole 300mm square x 250mm deep below the proposed invert level of the land drain.
- 2 Fill the hole with water to a depth of 250mm and allow to drain away over night.
- 3 Refill to a depth of at least 250mm and note the time taken (in seconds) to drain away completely.
- 4 Repeat the exercise two more times and calculate the average of the three results, as follows:

$$\text{percolation value (s)} = \frac{\text{time to drain away (seconds)}}{\text{depth of water (mm)}}$$

#### Results

percolation value	suitability
up to 100	use Appendix 5.3-C Chart 1 to determine field drain area
100 to 140	use Appendix 5.3-C Chart 1 but with underdrains*
over 140	field drains unsuitable

\* Where underdrains are necessary, drainage trenches should be constructed not less than 600mm deeper than the pipe level specified in the design, and the lower part filled with pea gravel (see Appendix 5.3-D)

A second system of drainage pipes should be laid on the bottom of the trenches to convey surplus drainage to an outfall in a surface ditch or watercourse.

Underdrains are costly, and a secondary treatment system able to produce an effluent suitable for surface discharge may be preferable.

**APPENDIX 5.3-C**

**Septic tank field drain design**

**Capacity based on Potential Occupancy**

Minimum capacity (litres)	Number of persons/bed spaces
2700	< 4
2720	4
2900	5
3080	6
3260	7
3440	8
3620	9
3800	10

Chart 1 Field Drains Trench Area

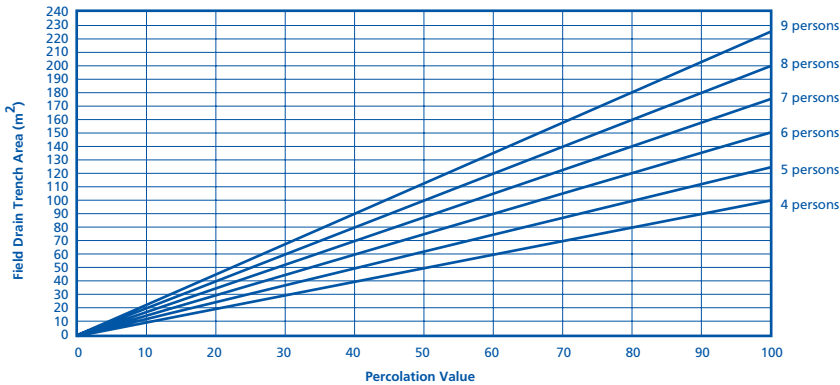
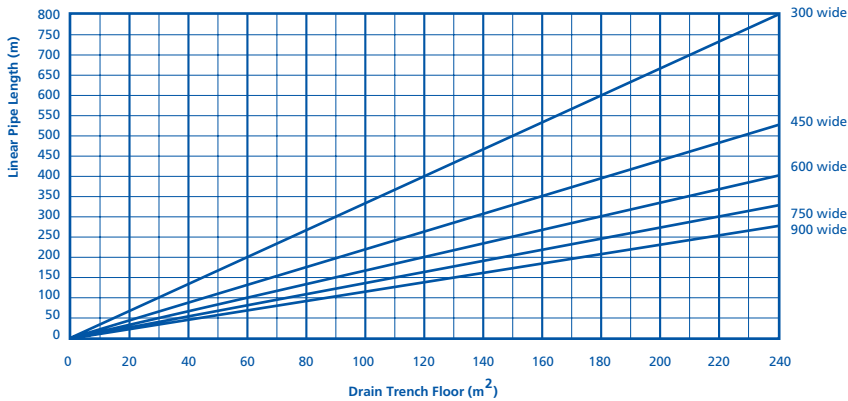

Chart 2 Field Pipe Length



5.3

# 5.3 Drainage below ground

## APPENDIX 5.3-D

### Cross section of typical underdrain

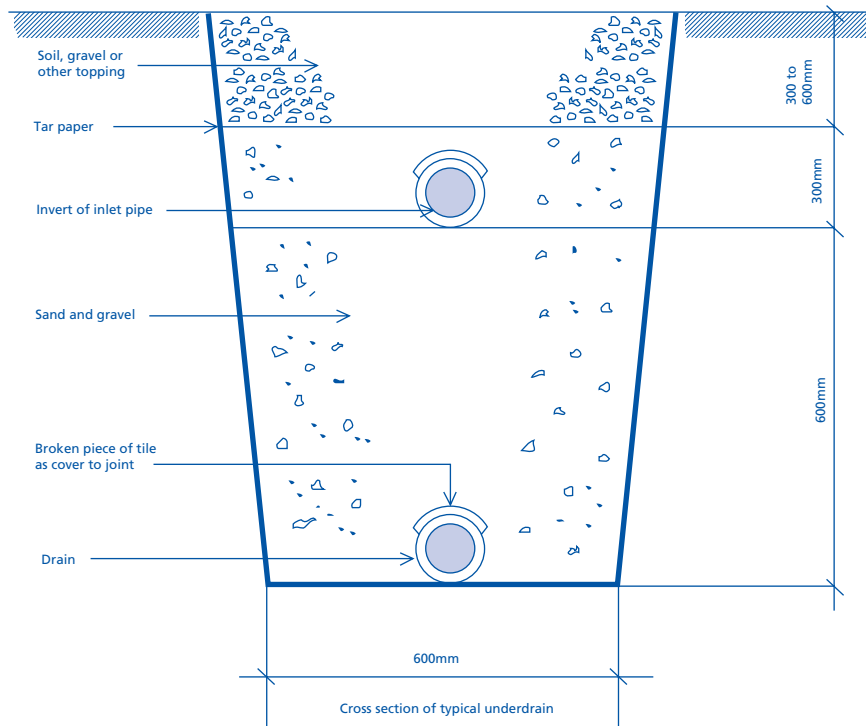

## APPENDIX 5.3-E

### Percolation tests and design method for surface water soakaways

#### PERCOLATION TEST

The rate at which water will disperse into the ground depends on the permeability of the ground, which varies with the soil type.

The test will give a fairly accurate assessment of how the ground drains. As the test hole can be used as part of a soakaway, it should be dug in a place that would be suitable for a soakaway, at least 5m from the foundations of a building.

A summary of the test procedure is given below:

#### TEST PROCEDURE

A trial hole in a similar location and to the same depth as the proposed soakaway or septic tank land drain will give a measured rate of percolation.

The procedure is as follows:

- 1 Bore a hole 150mm in diameter with an auger to a depth of one metre.
- 2 Fill with water to depth of 300mm above the bottom. As an aid, mark a stick 300mm from one end, place in the hole and fill up to the mark on the stick (it takes approximately 5.5 litres to fill a 150mm diameter hole to a depth of 300mm).
- 3 Observe the time taken in minutes for the water to soak away (this may take several hours, in some cases need to be left overnight).
- 4 If possible the test should be repeated and the average time used.
- 5 A second group of tests are carried out after the hole has been bored out to a depth of 2 metres, still using 300mm of water above the bottom of the hole.
- 6 If the soil appears to become more permeable with depth, it may be useful to deepen and retest the bore in one metre stages.

## DESIGN OF SOAKAWAY

The relationship between the diameter or effective depth required for a soakaway to suit a given area of roof and/or paved area, and the average time (t) given by the test outlined on the previous page, is shown on the graph below. The diameter and effective depth below invert level are assumed to be the same dimension (D).

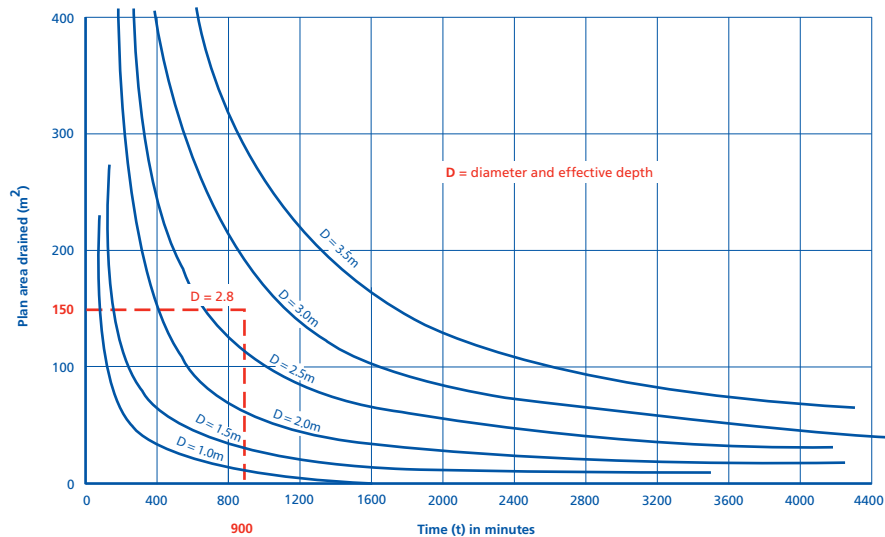

## EXAMPLE

Test time (t) = 900 minutes  
 Plan area to drain = 150m<sup>2</sup>

Therefore, using the graph, the diameter and effective depth of the soakaway (D) are both 2.8m.

## Notes

- If the ground is of low permeability, dig separate soakaways to drain smaller but distinct parts, for example:
  - one side of a roof to one soakaway
  - the other side to a second soakaway
  - the driveway or yard to a third soakaway.
- Where the permeability of the ground increases with depth, tests in the deepened trial holes will give shorter percolation times, so it may be cheaper to build a smaller soakaway at a greater depth below the surface.
- Where possible, soakaways should be built on land lower than, or sloping away from, buildings. They should also be kept a "safe" distance away from buildings. This should be at least 5m from building foundations. In chalk and other soil and fill material subject to modification or instability, the advice of a specialist geotechnologist should be sought regarding the siting and advisability of soakaways.

# 5.3 Drainage below ground

## INDEX

<b>A</b>		<b>G</b>		<b>S</b>	
Access	2, 6, 9	Garden areas	6	Septic tanks	1, 3, 7, 10, 11
<b>B</b>		Gradients	1	Sewage treatment works	4
Backfill	5, 6	Ground water	2, 3, 4	Soakaways	7, 12
Bedding	5	<b>J</b>		Subsoils	3
Benching	7	Jointing	5	Surface water	3, 7
Blockage	1	<b>L</b>		<b>T</b>	
Bricks and blocks	5	Landfill gases	1	Testing	8, 10, 12
<b>C</b>		Layout	4	<b>U</b>	
Capacity	1, 3	<b>M</b>		Underdrain	12
Cess pools	1, 3, 7	Manholes	4, 6, 7	<b>V</b>	
Chambers	4	Movement joints	6	Ventilation	1, 7
Chemicals	3	<b>O</b>			
Connections	3	Outfall	3, 4		
Covers	4	<b>P</b>			
<b>D</b>		Pipes	1, 2, 4		
Damage	2	Preliminary work	5		
<b>E</b>		Private sewers	1		
Excavation	5	Protection	6, 8		
<b>F</b>		Pumped systems	1		
Field drains	4, 11	<b>R</b>			
Fittings	4	Radon	1		
Flooding	2	Rendering	7		
Foul sewer	3	Rights of connection	1		
Foundations	5	Roads	6		

---

# Part 6

## Superstructure (excluding roofs)

---

- 6.1 External masonry walls
- 6.2 External timber framed walls
- 6.3 Internal walls
- 6.4 Timber and concrete upper floors
- 6.5 Steelwork
- 6.6 Staircases
- 6.7 Doors, windows and glazing
- 6.8 Fireplaces, chimneys and flues
- 6.9 Curtain walling and cladding
- 6.10 Light steel framed walls and floors







# Chapter 6.1

## External masonry walls

---



## CONTENTS

<b>DESIGN</b>	Clause	Page
Design standards	D1	1
Statutory requirements	D2	1
Structural design	D3	1
Exposure	D4	2
Mortar	D5	3
Damp-proof courses and cavity trays	D6	3
Wall ties	D7	4
Stone masonry	D8	4
Lintels	D9	4
Thermal insulation	D10-D11	5
Fire safety	D12	5
Sound insulation	D13	5
Claddings	D14	5
Rendering	D15	5
Provision of information	D16-D17	6

**MATERIALS**

Materials standards	M1	7
Bricks	M2	7
Blocks	M3	7
Stone masonry	M4	8
Mortar and rendering	M5	8
Dpc materials	M6	8
Wall ties	M7	8
Lintels	M8	8
Thermal insulation	M9	8
Cladding materials	M10	8
Movement joints	M11	9

**SITWORK**

Sitework standards	S1	9
Construction	S2	9
Stone masonry	S3	11
Damp-proof courses and cavity trays	S4	11
Wall ties	S5	12
Lintels	S6	13
Thermal insulation	S7	14
Rendering	S8	14
Cold weather working	S9	15
Handling and protection	S10	15

**APPENDIX 6.1-A**

Suitable wall constructions	16
-----------------------------	----

**APPENDIX 6.1-B**

Areas of severe exposure to frost attack	18
--	----

**APPENDIX 6.1-C**

Mortar mixes	20
--------------	----

**APPENDIX 6.1-D**

Dpcs and cavity trays	21
-----------------------	----

**APPENDIX 6.1-E**

Durability classification of bricks	22
-------------------------------------	----

**APPENDIX 6.1-F**

Protection of ancilliary components	22
-------------------------------------	----

**INDEX**

22

## SCOPE

This Chapter gives guidance on meeting the Technical Requirements and recommendations for external masonry walls.

**DESIGN STANDARDS**

**6.1 - D1 Design shall meet the Technical Requirements**

Design that follows the guidance below will be acceptable for external masonry walls.

**STATUTORY REQUIREMENTS**

**6.1 - D2 Design shall comply with all relevant statutory requirements**

Design should be in accordance with relevant Building Regulations and other statutory requirements.

**STRUCTURAL DESIGN**

**6.1 - D3 External cavity and solid walls shall be designed to support and transfer loads to foundations safely and without undue movement**

Items to be taken into account include:

**(a) standards**

Structural design should be in accordance with BS EN 1996-1-1.

Intermediate floors and roofs should be designed to provide lateral restraint to external walls, in accordance with BS 8103 and ancillary components to BS EN 845-1.

Walls of dwellings or buildings containing dwellings over three storeys high should be designed in accordance with Technical Requirement R5.

**(b) lateral restraint provided by concrete floors**

Concrete floors, with a minimum 90mm bearing onto the wall, provide adequate restraint.

Concrete floors running parallel to and not built into walls require restraint straps to provide restraint to the wall (reference should also be made to Chapter 6.4 'Timber and concrete upper floors' (each section)).

**(c) lateral restraint provided by timber floors**

Timber joisted floors can provide adequate restraint when joists are carried by ordinary hangers to BS EN 845 and connected to the wall with restraint straps.

In buildings of not more than two storeys, timber joisted floors can provide adequate restraint without strapping when:

- the minimum bearing onto masonry is 90mm (or 75mm onto a timber wall plate), or
- joists are carried by restraint type hangers, as described in BS EN 845-1 with performance equivalent to a restraint strap at not more than 2m centres.

**(d) point loads**

Padstones and spreaders may be necessary and, where required, should be located beneath areas of concentrated loads.

**(e) chases**

The position and depth of chases for services should be considered. Horizontal chases should be limited to one-sixth the thickness of a single leaf, and vertical chases to one-third the thickness of a single leaf.

Particular care is needed where hollow blocks are specified. Hollow blocks should not be chased, unless specifically permitted by the manufacturer.

**(f) bonding**

When partition walls abut the external wall and are of similar materials, they may be either fully bonded or tied together. Where materials have dissimilar shrinkage or expansion characteristics, eg dense concrete and aerated concrete, a tied joint is preferable as this will reduce the risk of random cracking.

In the case of a connection between a loadbearing wall on foundations and a non-loadbearing wall supported on a ground bearing slab, it is preferable to tie, not bond, the walls. This will reduce the risk of cracking due to differential vertical movement.

Tied joints should be formed using expanded metal, wire wall ties or a proprietary equivalent, at maximum 300mm intervals.

**(g) movement joints**

Movement joints should be provided, where necessary, and in such a way that stability is maintained. If no provision is made for both initial and long term movements, masonry walls may crack.

Vertical movement joints should be provided in the outer leaf to minimise the risk of major cracking, as shown in the following table:

Material	Joint width (mm)	Normal spacing
Clay brick	16	12m (15m maximum)
Calcium silicate brick	10	7.5 to 9m
Concrete block and brick	10	6m
Any masonry in a parapet wall	10	half the above spacings and 1.5m from corners (double the frequency)

The spacing of the first movement joint from a return should not be more than half of the above dimension.

When different materials are used together, consideration should be given to potential differential movement. Wall ties are needed on either side of movement joints (reference should be made to Clause D7 and Sitework clause 6.1 - S5).

Movement joints should run the full height of the masonry wall. Any movement joints provided in the substructure must be carried up into the superstructure. Movement joints may be needed in the superstructure where none are required in the substructure - however suitable allowance should be made for relative movement.

Where masonry walls form panels in a framed structure, movement joints should be provided in accordance with BS EN 1996-2.

Details of suitable materials to form movement joints are given in the Materials section of this chapter.

Where movement joints are provided to control shrinkage in concrete blockwork, they may be simple vertical joints filled with mortar and sealed.

To ensure the sealant is effective, there should be a good bond with the masonry. The sealant should be at least 10mm deep or in accordance with manufacturers' instructions.

Movement joints are not normally necessary to the inner leaf of cavity walls but consideration should be given to providing:

- movement joints in rooms with straight unbroken lengths of wall over 6m. This is unnecessary for fired clay bricks
- bed joint reinforcement as an alternative to movement joints in areas of risk, eg under window openings.

To reduce cracking and to maintain the level of thermal resistance:

- bricks and blocks, or blocks of different densities, in a wall should not be mixed
- a joint should be formed where dissimilar materials abut
- the joint should be tied (eg with expanded metal in the bed joint) unless the joint is to act as a movement joint.

Where cracking is likely, walls should be dry lined or clad (reference should also be made to Sitework clause 6.1 - S2(g)).

**(h) calcium silicate brickwork**

Design of calcium silicate brickwork should follow the the brick manufacturer's recommendations.

**(i) cladding to framed structures**

Allowance should be made for differential movement between cladding and frame.

The following precautions should be taken to prevent buckling and fracturing of masonry panels:

- flexible movement joints should be provided at the underside of each horizontal support member
- the masonry outer leaf should have at least two-thirds of its width supported securely by the concrete frame or a metal angle
- the inner leaf should be adequately tied to the structural frame. Forked plate ties held in dovetail slots, cast into the column or an equivalent are acceptable
- vertical movement joints should be provided at corners.

For timber framed construction, reference should be made to Chapter 6.2 'External timber framed walls' (Design).

#### (j) corbelling

The size of corbels should not exceed the dimensions given in Sitework clause 6.1 - S2(j).

## EXPOSURE

### 6.1 - D4 External walls shall be suitable for their exposure and resist the passage of moisture to the inside of the dwelling

In this Chapter, reference is made to exposure to:

- wind driven rain
- frost attack.

Details of how these are defined are contained in Appendices 6.1-A and 6.1-B.

Items to be taken into account include:

#### (a) general aspects affecting durability

Masonry in the following locations is particularly likely to become saturated and may remain so for long periods. Precautions as necessary should be taken to resist frost damage and sulfate attack in:

- parapet walls and copings
- sills and projections
- masonry below dpc at ground level
- freestanding walls.

The selection of bricks and mortar should follow the recommendations given in BS EN 1996-1-1 and manufacturers' recommendations.

In addition to the mortar designations given in BS EN 1996-1-1, the following mortar mixes can be used with ordinary Portland cement or sulfate-resisting cement:

- air-entrained 1 : 1 : 5½ cement : lime : sand, or
- air-entrained 1 : ½ : 4½ cement : lime : sand.

Sulfate-resisting cement should be used where clay bricks with S1 designation are used as follows:

- below dpc where there are sulfates present in the ground

- below dpc where there is a high risk of saturation
- retaining walls
- parapets
- freestanding walls
- rendered walls
- areas of *Severe* or *Very Severe* exposure to driving rain.

Reclaimed bricks should be used only in accordance with Technical Requirement R3.

#### (b) rain penetration

Rainwater will penetrate the outer leaf of a masonry wall in prolonged periods of driving rain. Resistance to rain penetration of masonry walls can be improved by cladding the wall. Total resistance can only be achieved with an impervious cladding.

The following should be taken into account to minimise the risk of rain penetration:

- determination of the exposure to wind driven rain
- a suitable wall construction and insulation method
- design detailing for the local exposure, taking into account the likely quality of workmanship on site.

A very high standard of workmanship is required to ensure that cavities are not bridged. Where full or partial cavity insulation is proposed, the installation should follow the recommendations of any assessment and the manufacturer.

The most exposed part of the building should be given particular attention when selecting a suitable construction method as this may affect the choice for the whole building.

The following aspects of design can reduce the risk of rain penetration:

- *providing cladding (other than render)* to the wall. Even if cladding is only added to gable walls and upper floors, it reduces rain penetration
- *increasing the clear cavity width or the width of full cavity insulation.* Increasing the cavity width for full cavity insulation from 50mm to 75mm or more greatly reduces the risk of rain passing through the cavity. A nominal cavity of 50mm is always required on the outside of partial cavity insulation
- *rendering the wall* (reference should also be made to Clause D15). Specify backing material carefully to avoid cracking which can reduce the effectiveness of render against rain penetration
- *designing protective features to keep the wall dry*, eg projecting sills and deep overhanging eaves and verges
- *mortar joints.* All joints should be fully filled. Where full cavity insulation is proposed, recessed joints should not be used. Reference should also be made to Clause D5(c).

In areas of *Very Severe* exposure to driving rain and in Scotland the cavity should not contain full fill insulation.

In Scotland, Northern Ireland, the Isle of Man and in other places where the exposure to driving rain is *Very Severe*, masonry should form a rebate at the reveals of openings to avoid a straight through joint where the frame abuts the masonry.

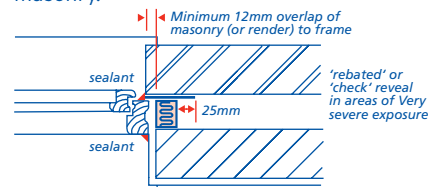

Proprietary cavity closers may be an acceptable alternative provided they have been assessed in accordance with Technical Requirement R3. For information on doors and windows, reference should be made to Chapter 6.7 'Doors, windows and glazing' (each section).

In Scotland and areas of *Severe* or *Very Severe* exposure to driving rain, cavities should be continuous around enclosed porches and habitable areas.

Cavity trays should be used at junctions with roof (reference should also be made to Clause D6).

Sills, copings and the like should be weathered and throated unless adequate alternative provision is made to protect the brickwork from saturation, frost damage and staining.

#### (c) frost attack

The main factors affecting frost attack are:

- degree of exposure (incidence of frost)
- saturation of the masonry
- frost resistance of the masonry
- localised protection of the masonry by roof overhangs, trees and other buildings.

Areas of severe frost exposure are shown on the map in Appendix 6.1-B.

In areas of exceptionally severe frost exposure, which is defined as a location which is in a severe frost exposure area and, in addition, faces long stretches of open countryside, only frost-resistant bricks (F2,S2 or F2,S1 to BS EN 771) are acceptable for the superstructure.

In areas of severe frost exposure, the following are acceptable:

- clay facing bricks which are frost-resistant (F2,S2 or F2,S1 to BS EN 771). Reference should be made to Appendix 6.1-E for the freeze/thaw resistance classification of bricks to BS EN 771
- clay bricks which are classified in manufacturers' published recommendations as satisfactory for the exposure
- calcium silicate bricks (in accordance with BS EN 771)
- concrete bricks with a strength not less than 20N/mm<sup>2</sup>

- concrete blocks with a density not less than 1500kg/m<sup>3</sup> or of strength not less than 7.3N/mm<sup>2</sup>
- most types of aerated concrete blocks with render.

In Scotland, all clay bricks used as facings should be frost-resistant (F2,S2 or F2,S1 to BS EN 771).

If there are doubts about the suitability of a facing brick for sites in areas of exceptionally severe frost exposure classification, written confirmation should be obtained from the brick manufacturer that the brick is suitable for:

- its geographical location, and
- its location in the structure.

This applies particularly to bricks such as fletton facings which are moderately freeze/thaw resistant (F1,S2 or F1,S1). In addition, follow manufacturers' recommendations on suitability, including the choice and use of mortar and the type of pointing.

Recessed joints should only be used in compliance with Clause D5(c).

Bricks that are not frost-resistant (F0,S2 or F0,S1 to BS EN 771) may not be acceptable for use externally, unless completely protected by a cladding which can adequately resist the passage of water.

Good brickwork detailing can limit persistent wetting of brickwork and reduce the risk of frost attack.

For example:

- paths should drain away from walls to avoid saturating bricks near the ground
- sills, copings and the like should have a weathered upper surface
- a coping should be provided for all parapet walls, chimneys and freestanding walls unless clay bricks of F2,S1 or F2,S2 classification to BS EN 771 have been used. Copings should have a generous overhang, throatings at least 40mm clear of the wall and a continuous, supported dpc underneath which projects beyond the line of the wall. Single leaf parapet walls should not be rendered on both sides.

Where there is a risk that brickwork may be persistently wet, bricks should be specified that are low in soluble salts (if clay, F2,S2 or F1,S2 to BS EN 771).

#### Note

Only clay bricks designated L by BS EN 771 have a low limit on their soluble salt content. In persistently wet conditions, clay bricks of S1 designation may create sulfate attack on the mortar.

Painted or decorated finishes can trap moisture in external brickwork and increase the risk of frost damage, sulfate attack or other detrimental effects. They should not be applied to S1 designation

bricks without the brick manufacturer's written agreement.

## MORTAR

### 6.1 - D5 Mortar shall be of the mix proportions necessary to achieve adequate strength and durability and be suitable for the type of masonry

Items to be taken into account include:

#### (a) geographical location and position within the structure

Recommended mortar mixes for different locations are given in Appendix 6.1-C.

#### (b) sources of sulfate

Ordinary Portland cement mortar can expand, crumble and deteriorate badly if attacked by sulfates. Sufficient soluble sulfate to cause this problem may be contained in clay bricks. Clay bricks with an S1 designation have no limit on their sulfate content. The problem is most acute when brickwork is saturated for long periods; mortar is vulnerable to attack by any soluble sulfates present.

To reduce the risk, sulfate-resisting Portland cement to BS 4027 should be used:

- below dpc level when sulfates are present in the ground
- when clay bricks (F2,S1 and F1,S1 to BS EN 771) are used, and there is a high saturation risk, for example in the following situations:
  - parapets
  - chimney stacks
  - retaining walls
  - freestanding walls
  - rendered walls
  - areas of Severe or Very Severe exposure to driving rain.

#### (c) joints

Struck (or weathered) and bucket handle joints are preferable.

Recessed joints should not be used where:

- bricks are perforated nearer than 15mm to the face
- bricks are not frost resistant (if clay F1,S1 or F1,S2 to BS EN 771), unless the brick manufacturer has agreed in writing for their use in a particular location
- there is no reasonable shelter from driving rain (reasonable shelter could be from buildings or groups of trees if these are within 50m and of similar height to the dwelling)
- the dwelling is built on steep sloping ground, facing open countryside or within 8km of a coast or large estuary
- the cavity is to be fully filled with cavity insulation.

Jointing is preferable to pointing because it leaves the mortar undisturbed.

#### (d) admixtures and additives

Calcium chloride should not be used as an admixture to mortar. The contents of admixtures should be checked to ensure that they do not contain calcium chloride.

Admixtures should only be used in accordance with manufacturers' recommendations/instructions.

Mortars containing an air-entraining plasticiser are more resistant to freeze/thaw damage when set.

White cement to BS EN 197 and pigments to BS 1014 may be used, but pigments should not exceed 10% of the cement weight or 3% if carbon black is used.

Further advice concerning admixtures is given in Appendix 6.1-C.

## DAMP-PROOF COURSES AND CAVITY TRAYS

### 6.1 - D6 Damp-proof courses and related components shall be provided to prevent moisture rising or entering the building

Items to be taken into account include:

#### (a) dpcs

Damp-proof courses should be provided in accordance with the Table in Appendix 6.1-D.

At complicated junctions, clear drawings should be provided and preformed profiles specified. Isometric drawings can sometimes be clearer than the combination of plan and section/elevation drawings.

#### (b) cavity trays

Cavity trays should be provided at all interruptions to the cavity, eg window and door openings, air bricks, etc, unless otherwise protected, eg by overhanging eaves.

A cavity tray should:

- provide an impervious barrier and ensure that water drains outwards
- project at least 25mm beyond the outer face of the cavity closure or, where a combined cavity tray and lintel is acceptable, give complete protection to the top of the reveal and vertical dpc where provided
- provide drip protection to door and window heads
- have an overall minimum upstand from the inside face of the outer leaf to the outside of the inner leaf of 140mm
- be shaped to provide at least a 100mm vertical protection above a point where mortar droppings could collect.

# 6.1

## External masonry walls

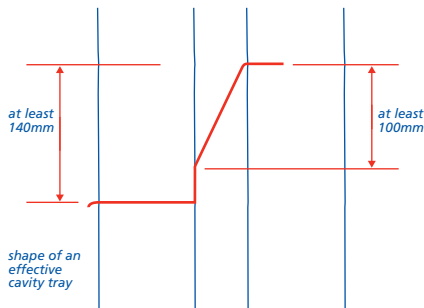

In Scotland, Northern Ireland, the Isle of Man and areas of Very Severe exposure to driving rain, the upstand part of the damp-proof protection should be returned into the inner leaf of masonry except at sloping abutments. In all other areas, the upstand should be returned into the inner leaf unless it is stiff enough to stand against the inner leaf without support.

Where fairfaced masonry is supported by lintels:

- weep holes should be provided at 450mm (maximum) centres with at least two weep holes per opening
- cavity trays or combined lintels should have stop ends.

Where full fill insulation is placed in the cavity, a cavity tray should be used above the highest insulation level, unless the insulation is taken to the top of the wall. (Manufacturers' recommendations should be followed.)

### (c) abutment details

Cavity trays should be provided at abutments of roofs and cavity walls. This will ensure that any water penetrating into the cavity does not enter the enclosed area. This only applies where the roof is over an enclosed area, including an attached garage, but does not apply to open car ports and open porches.

Where the roof abuts at an angle with the wall, preformed stepped cavity trays should be provided.

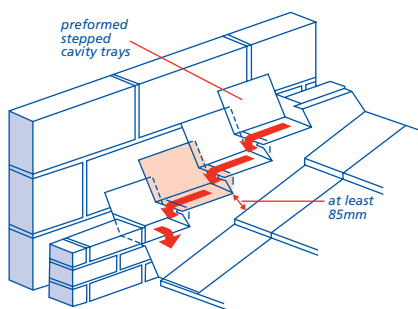

### (d) parapet details

Dpcs below the coping should be supported over the cavity to prevent sagging. A dpc should be specified that can achieve a good key with the mortar.

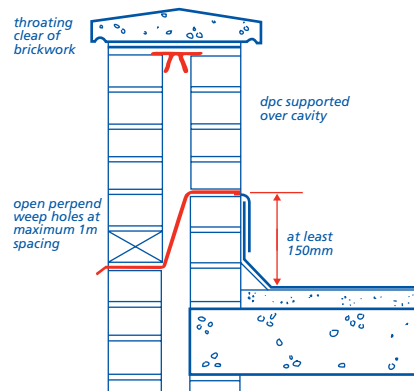

### (e) materials

Materials that are suitable for use as dpcs are given in Materials clause 6.1 - M6.

## WALL TIES

### 6.1 - D7 Wall ties shall be provided, where required, to tie together the leaves of cavity walls

The spacing of wall ties in masonry walls should be in accordance with Sitework clause 6.1 - S5.

Details of suitable wall ties are given in the Materials section of this Chapter.

## STONE MASONRY

### 6.1 - D8 Elements constructed of natural or cast stone masonry shall comply with the performance standards for brick and block masonry, where applicable

Stone masonry (natural or cast stone) should be designed to meet the requirements of BS EN 1996 'Design of masonry structures'.

## LINTELS

### 6.1 - D9 Lintels shall safely support the applied loads

Items to be taken into account include:

#### (a) structural support

Concrete, steel and reinforced brickwork are acceptable materials for use as lintels.

Timber lintels should not be used, unless:

- they are protected from the weather, and
- they do not support masonry or other rigid or brittle materials.

Lintels should be designed in accordance either with Technical Requirement R5 or manufacturers' published data. A lintel should be provided where frames are not designed to support superimposed loads.

Lintels should be wide enough to provide adequate support to walling above. Masonry should not overhang the lintel support by more than 25mm. A lintel should extend beyond the opening at each end by at least the following lengths:

Minimum bearing length (mm)		
Span (m)	Simple lintel	Lintel combined with cavity tray
Up to 1.2	100	150
Over 1.2	150	150

To avoid overstressing, composite lintels should have the required depth of fully bedded brickwork stipulated by the manufacturer above the lintel, before point loads are applied. Where necessary, padstones and spreaders should be provided under the bearings of lintels. Reference should be made to Chapter 6.5 'Steelwork support to upper floors and partitions' (Design) for details of padstones.

### (b) adequate durability against corrosion and resistance to water entering the dwelling

Cavity tray/damp-proof protection should be provided over all openings, either as a combined part of the lintel or separately. Reference should be made to Clause D6(b).

Steel and concrete lintels should comply with BS EN 845-2.

Separate cavity tray protection should be provided when:

- the profile of the lintel is not as shown in Clause D6(b), or
- steel lintels have materials coatings references L11, L14 and L16.1 and are used in external walls

Lintels used in aggressive environments (e.g. coastal sites) should be austenitic stainless steel.

In Scotland, Northern Ireland, the Isle of Man and areas of *Severe* or *Very Severe* exposure to driving rain, separate damp-proof protection should be provided over all lintels in accordance with the guidance for cavity trays given in Clause D6(b).

Lintels should be of such a size and be located so that the external edge of the lintel projects beyond, and therefore offers protection to, the window head.

### (c) cold bridging and condensation

The BRE Report 'Thermal insulation: avoiding risks' discusses aspects of insulation relevant to external masonry walls. In England and Wales account should be taken of Accredited Details.

The risk of condensation at reveals and soffits becomes more likely as the wall insulation increases. Cold bridge paths should be avoided.

To avoid a cold bridge, the wall insulation should ideally abut the head of the window frame.

Clause D4(b) details methods of preventing rain penetration which may also be required.



**(d) adequate fire resistance**

Where steel lintels are used, manufacturers' recommendations for providing adequate fire resistance, particularly to the lower steel flange, should be followed.

**THERMAL INSULATION****6.1 - D10 External walls shall be designed to provide the required standard of thermal insulation**

The insulation value of the wall must meet the requirements of the relevant Building Regulations.

Design should avoid cold bridging at openings and at junctions of external walls with roofs, floors and internal walls.

**6.1 - D11 External walls shall be designed to ensure the correct use of insulation materials**

Items to be taken into account include:

**(a) acceptable insulation materials**

Insulation, or lightweight aerated concrete blocks, or blocks with face bonded insulation, or voided blocks with insulation infill should be used in accordance with:

- an assessment which complies with Technical Requirement R3, or
- a British Standard and the relevant Code of Practice.

**(b) full cavity insulation**

In Northern Ireland and the Isle of Man, it is not permissible to fill cavities with pumped thermal insulants at the time of construction.

In Scotland, it is not permissible to fill the full width of the cavity with *any* thermal insulants at the time of construction.

The type of insulation, its thickness and the wall construction should be suitable for the exposure of the dwelling in accordance with Appendix 6.1-A.

Materials clause 6.1 - M9 sets out the range of acceptable insulation materials and the relevant British Standards.

Render on an external leaf of clay bricks (F2,S1 or F1,S1 designation bricks to BS EN 771) in *Severe* or *Very Severe* exposures is not permitted where the cavity is to be fully filled with insulation.

The following design points should be noted:

- stop ends should be provided to cavity trays or combined lintels
- weepholes should be provided at 450mm (maximum) centres with at least two per opening
- mortar joints should not be recessed
- painted finishes on bricks or render are not acceptable if they are likely to cause frost damage or sulfate attack or other damage.

**(c) partial cavity insulation**

Partial cavity insulation should be fixed only against the cavity face of the inner leaf. The clear cavity width between partial cavity insulation and the outer leaf should be at least 50mm nominal. In areas of *Very Severe* exposure in England and Wales, a residual cavity of 75mm is required where the outer leaf is fair faced masonry.

Wall ties should be long enough to allow a 50mm embedment in each masonry leaf.

**(d) inner leaf of insulated blockwork**

Types of blockwork include:

- lightweight aerated concrete
- lightweight aggregate blocks
- voided blocks with insulation infill
- blocks faced with insulation material.

Manufacturers' recommendations should be followed and particular note taken of the following:

- a clear 50mm wide cavity should always be maintained
- the blocks should be capable of supporting concentrated loads
- the correct type of joist hanger for the type and size of block and size of joist should be used
- long unbroken lengths of blockwork should be avoided
- precautions should be taken to reduce risk of shrinkage cracking
- dry lining should be used where shrinkage cracking might be unsightly and to avoid long term pattern staining at mortar joints
- restrictions on chasing for services when using voided blocks should be noted (reference should be made to Clause D3(e)).

**(e) dual insulation**

Where partial cavity insulation is used in addition to an insulated block inner leaf (reference should be made to Clause D11(c)), the whole composite construction should have been assessed in accordance with Technical Requirement R3.

**(f) insulated dry linings**

Where an insulated dry lining contains a combustible insulant, the plasterboard should be at least 12.5mm thick and mechanically fixed to the masonry inner leaf. This is to prevent early collapse of the lining in a fire.

**FIRE SAFETY****6.1 - D12 Cavity walls shall adequately resist the passage of fire**

Cavities should be closed with cavity closers in accordance with statutory requirements.

**SOUND INSULATION****6.1 - D13 External walls adjacent to sound-resisting walls shall be designed to adequately resist flanking sound transmission**

Acceptable levels of sound reduction between dwellings may be achieved by:

- the inner leaf of an external cavity wall having sufficient weight, and
- sealing of air paths
- allowing appropriate spacings between openings in external walls.

The density of external walls and the position of openings adjacent to sound-resisting walls should be in accordance with statutory requirements and, where relevant, an assessment which complies with Technical Requirement R3.

**CLADDINGS****6.1 - D14 Cladding shall satisfactorily resist the passage of moisture**

Items to be taken into account include:

**(a) battens**

Where battens are required, they must be pre-treated with preservative, as described in Chapter 2.3 'Timber preservation (natural solid timber)' (each section).

**(b) joints**

Joints between claddings and adjacent materials should be detailed to be watertight under the particular exposure conditions of the site. Where necessary, provision should be made for differential movement.

**(c) moisture barriers**

Unless specifically not required for a proprietary cladding, moisture barriers should be provided between walls of solid masonry and any boarding, slating, tiling or other similar claddings. The moisture barrier may be roofing underfelt or equivalent.

Vapour barriers such as polyethylene sheet are not an acceptable moisture barrier as they can trap moisture in the structure.

For timber framed walls clad with masonry, reference should be made to Chapter 6.2 'External timber framed walls' for details.

**(d) vertical tile or slate cladding**

Every tile or slate should be nailed with two nails. Nails should be aluminium, copper or silicon bronze.

Bottom edges should be finished with an under-course and tilting batten.

**(e) timber cladding**

Timber claddings should be pre-treated with preservative in accordance with Chapter 2.3 'Timber preservation (natural solid timber)' (each section).

## RENDERING

**6.1 - D15 Rendering, in conjunction with the surface to which it is applied, shall satisfactorily resist the passage of moisture**

Items to be taken into account include:

### (a) rain penetration

External rendered finishes should comply with BS EN 13914 'Design, preparation and application of external rendering and internal plastering' and the guidance given below.

It is important to prevent rainwater penetrating behind the rendering. Design features around openings and at the head of the rendering should provide shelter, where possible, and help to shed water away from the surface below.

### (b) exposed elements

It is not advisable to render exposed parts of a building, such as parapets and chimneys constructed of clay bricks of S1 designation, without the use of sulfate-resisting cement.

### (c) movement

Movements can occur at a change in material. In such cases, the render should be either stopped at specially formed movement joints or, if the expected movement is small, be reinforced by metal lathing carried across the joint. If metal lathing is used, three rendering coats should be applied.

### (d) background

To achieve a good bond, the masonry backing should be moderately strong and porous to give some suction and a mechanical key. Dense masonry with a smooth surface should not be rendered.

Aerated or lightweight aggregate concrete blocks can be used, as a background, but more care is needed when selecting a rendering mix and surface treatment. Strong render mixes should not be used. Roughcast and dry dash finishes that require a strong mix are not recommended for use on aerated or lightweight aggregate blocks. Block manufacturers' recommendations should be followed.

In Scotland, render should be applied only to bricks:

- which are keyed, or
- where a spatterdash coat has been applied before the first render undercoat.

In other areas, render should be applied only to bricks where either:

- keyed bricks are used, or
- the joints are raked out at least 15mm deep.

Render may be applied to bricks (if clay F2,S1 or F1,S1 to BS EN 771) only if the following conditions are met:

- cement for brickwork mortar is sulfate-resisting to BS 4027
- the brick manufacturer has confirmed, in writing, that the brick is suitable, taking account of the brickwork detailing and the particular exposure of each rendered element. If sulfate-resisting cement is used in the mortar, it should also be used in spatterdash coats and base coats of the render.

Care should be taken when specifying render to walls with full cavity fill. The lack of a ventilated cavity can slow down the rate at which the wall dries out.

Rendered finishes should not be used over fully filled cavity walls if:

- the outer leaf is built in bricks with S1 designation (F2,S1 and F1,S1 to BS EN 771), and
- the site is in an area classed as Severe or Very Severe exposure to driving rain (see Appendix 6.1-A).

Rendering may be used on brickwork with partial cavity insulation provided a clear cavity width between insulation and outer leaf of at least 50mm nominal is maintained.

### (e) mixes

The rendering mix should be appropriate to the strength of the background. No render coat should be stronger than the background or richer than the preceding coat. The render should be of adequate strength to achieve durability.

Mixes should comply with the recommendations of BS EN 13914 'Design, preparation and application of external rendering and internal plastering'. When rendering on bricks that are F1,S1 or F1,S2 to BS EN 771, the Table to Sitework clause 6.1 - S8(b) should be followed. The manufacturer of the background masonry should be consulted regarding particular requirements for the mix or its application.

Pigments complying with the requirements of BS 1014 may be added to the finishing coat up to a limit of 10% of the cement weight or 3% in the case of carbon black. White Portland cement may be used.

### (f) number and thickness of coats

The number of coats should be chosen with regard to the background and the exposure conditions of the site.

For rendering on masonry cavity walls, one undercoat and one finishing coat is acceptable. On metal lathing or on solid wall construction, two undercoats and one finishing coat are required.

Initial undercoats should not be less than 10mm and not more than 15mm thick. Any further undercoat should be thinner than the preceding coat. Finishing coats should be generally between 6mm and 10mm thick.

Undercoats should be allowed to shrink and dry out before applying following coats. When rendering onto dense concrete blocks, adhesion can be improved by use of proprietary bonding agents or a spatterdash coat.

### (g) detailing of timber/brick/render

Dwellings which incorporate rendered panels between timber boards should have at least one coat of render applied over the whole wall face before the boards are fixed. The second coat may be applied between the boards.

Rendering and timber can shrink causing gaps. Precautions should be taken to prevent rain from penetrating the junction as this might cause the render to fail as a result of frost damage.

All exposed timber, except naturally durable species, should be treated in accordance with Chapter 2.3 'Timber preservation (natural solid timber)' (each section).

Where timber is used on brick or render, it is essential that all cut ends, mortices, etc made after treatment are flood coated with preservative.

Large section timbers should be fitted with suitable weather bars, flashings, etc to prevent moisture penetration through joints with adjacent materials.

Non-ferrous fixings should be used. Aluminium is not suitable when the preservative is Copper/Chromium/Arsenic.

### (h) proprietary and local rendering systems

Proprietary rendering finishes should be applied in accordance with manufacturers' recommendations.

Traditional local rendering should comply with the above guidance, as appropriate, and with established local practice.

## PROVISION OF INFORMATION

**6.1 - D16 Designs and specifications shall be produced in a clearly understandable format and include all relevant information**

For external masonry walls, the drawings should show:

- wall layout with all dimensions shown
- position and size of openings
- coursing of the bricks and blocks in relation to storey heights and opening positions
- details at all junctions, indicating position of dpcs and cavity trays. Isometric sketches are recommended for complicated junctions
- position and type of lintels
- position of restraint straps
- details of cavity closers
- details at reveals



- details of how support is given to other elements, eg padstones and wall plates
- position and detail of movement joints
- acceptable methods of pointing or mortar joint finish
- type of insulant to be used
- type and location of wall ties.

#### 6.1 - D17 All relevant information shall be distributed to appropriate personnel

Ensure that design and specification information is issued to site supervisors and relevant specialist subcontractors and/or suppliers.

Where proprietary products are to be used, manufacturers usually have specific requirements for fixing and/or assembly of their products. This information should also be made available for reference on site so that work can be carried out satisfactorily in accordance with the design and specification.

## MATERIALS STANDARDS

#### 6.1 - M1 All materials shall:

- (a) meet the Technical Requirements
- (b) take account of the design

Materials that comply with the design and the guidance below will be acceptable for external masonry walls.

Materials for external masonry walls shall comply with all relevant standards, including those listed below. Where no standard exists, Technical Requirement R3 applies (see Chapter 1.1 'Introduction to the Standards and Technical Requirements').

References to British Standards and Codes of Practice include those made under the Construction Products Directive (89/106/EEC) and, in particular, appropriate European Technical Specifications approved by a European Committee for Standardisation (CEN).

## BRICKS

#### 6.1 - M2 Bricks shall:

- (a) be capable of supporting intended loads

Requirements for the design strength of bricks are given in BS EN 1996-1-1. The brick specified in the design should be used. Clay bricks to BS EN 771 with a minimum compressive strength of 9N/mm<sup>2</sup> should be adequate for one and two storey dwellings and 13N/mm<sup>2</sup> for three storey dwellings.

- (b) have appropriate resistance to the adverse effects of freeze/thaw and sulfate attack

#### CLAY BRICKS

BS EN 771 classifies clay bricks according to their freeze/thaw resistance and soluble salt content (see Appendix 6.1-E).

Only bricks that are freeze/thaw resistant (F2,S2 or F2,S1 to BS EN 771) should be used where there is a high risk of prolonged wetting and freezing. Such areas include:

- all external facing work in Scotland
- exposed parts including copings, sills and parapets and chimneys which have no overhang to provide protection. Reference should be made to Design clause 6.1 - D4(c)
- areas of the country subject to *exceptionally severe* freeze/thaw exposure (see map in Appendix 6.1-B).

In areas of severe freeze/thaw exposure outside Scotland, bricks that are moderately freeze/thaw resistant (F1,S1 or F1,S2 to BS EN 771) may be used for general wall areas, provided they are classified in manufacturers' published recommendations as satisfactory for the exposure.

Bricks that are not freeze/thaw resistant (F0,S2 or F0,S1 to BS EN 771) are not acceptable for use externally, unless completely protected by a cladding which can resist satisfactorily the passage of water.

Where brickwork may become saturated, moderately freeze/thaw resistant bricks (F1,S1 or F1,S2 to BS EN 771) are not appropriate if there is a risk of vulnerability to frost. In saturated conditions, sulfate-resisting cement mortar is required for S1 designation bricks.

#### CALCIUM SILICATE BRICKS

Bricks of compressive strength Class 20 (to BS EN 771-2) are suitable for most applications. Bricks of strength Class 30 and declared as freeze/thaw resistant (to BS EN 771-2) are recommended in areas of severe freeze/thaw exposure (see map in Appendix 6.1-B) or for use where bricks may be persistently wet (eg parapets, chimneys, sills and below dpc).

Calcium silicate bricks do not contain significant amounts of soluble sulfates and may be suitable where sulfate bearing soil and ground water conditions exist. Manufacturers' recommendations should be followed.

#### CONCRETE BRICKS

In concrete bricks there is a direct relationship between strength and durability, including freeze/thaw resistance. Most concrete bricks in production have a strength of 20N/mm<sup>2</sup> and are durable in most situations. For copings and sills, bricks with a compressive strength of 36N/mm<sup>2</sup> should be used.

#### RECLAIMED BRICKS

Reclaimed bricks could be unsuitable for external work because of a high salt content or a lack of freeze/thaw resistance. Their use is permitted only in accordance with Technical Requirement R3. It is advisable to know where they come from, both geographically and within the previous building. Bricks used internally or fully protected may be unsuitable in external situations.

Reclaimed bricks should be considered as F1,S1 or F1,S2 to BS EN 771 and used accordingly. Independent certification of suitability may be required.

#### SPECIAL SHAPED BRICKS

Special shaped bricks should conform to BS 4729.

## BLOCKS

#### 6.1 - M3 Concrete blocks shall:

- (a) be capable of supporting intended loads

Blocks should comply with BS EN 771 and be used in accordance with BS EN 1996-2.

In general, 2.9N/mm<sup>2</sup> blocks are suitable for one and two storey dwellings.

For three storey dwellings or dwellings with storey heights over 2.7m, 7.3N/mm<sup>2</sup> blocks are required for certain parts of the structure.

Structural design may show that strengths lower than 7.3N/mm<sup>2</sup> are adequate.

Other factors may dictate the strength of blocks required in certain circumstances, eg sulfate-resistance may require blocks of greater strength.

The maximum loadbearing capacity of the wall should not exceed manufacturers' recommendations.

- (b) have appropriate resistance to adverse effects of freeze/thaw and sulfate attack

Concrete blocks used in the outer leaf without protective cladding or render, should:

- have a compressive strength exceeding 7.3N/mm<sup>2</sup>, or
- have a density exceeding 1500kg/m<sup>3</sup>, or
- be made with dense aggregate to BS EN 12620, or
- be lightweight aerated concrete blocks having had their suitability confirmed by the manufacturer.

Concrete blocks should not be used below dpc where there are sulfates in the ground, unless suitability is confirmed by the block manufacturer. Sulfates may attack the cement used in the block. Sulfate-resisting cement will be required in the mortar. The proportions will depend on the level of sulfates in the ground.

**(c) have an adequate thermal resistance, where required**

The designer may have specified a particular type and thickness of concrete block because of its thermal insulation performance in addition to its strength. Alternative concrete blocks should not be used without the designer's acceptance.

**STONE MASONRY****6.1 - M4 Stone masonry shall be capable of supporting the intended loads and have appropriate resistance to the adverse effects of freeze/thaw**

Stone for masonry should conform to the requirements of BS EN 771-6.

Cast stone masonry units should comply with BS EN 771-5 or BS 1217 as appropriate.

**MORTAR AND RENDERING****6.1 - M5 Mortar and rendering materials shall be of the mix proportions to achieve adequate strength and durability to comply with the design**

Items to be taken into account include:

**(a) cement and lime**

Ordinary Portland cement should be to BS EN 197. Sulfate-resisting Portland cement should be to BS 4027. Masonry cement should be to either BS EN 197 or BS EN 413.

Limes should conform to BS EN 459.

**(b) sand type**

Sand and aggregate from natural sources should conform to BS EN 13139.

**(c) mortar type**

Ready-mixed mortars should comply with BS EN 998. For recommended mortar mixes, see Appendix 6.1-C.

**(d) additives**

Air entraining and set retarding admixtures should comply with BS EN 934.

Pigments for colouring mortars should conform to BS EN 12878.

**(e) render**

Sand for render should be sharp sand to BS EN 13139, preferably from the coarse end of the grading scale. Sand with excessive fine material will shrink and crack.

[Reinforcement for render, including angle beads, corner beads, stop beads and render stops, should be stainless steel or PVC.](#)

Decorative finishes that contain asbestos are not acceptable.

**DPC MATERIALS****6.1 - M6 Materials for damp-proofing shall resist adequately the passage of moisture**

Items to be taken into account include:

**(a) dpcs**

The following materials are acceptable for use as dpcs:

- bitumen to BS 6398
- polyethylene to BS 6515 (except below copings and in parapets)
- proprietary materials assessed in accordance with Technical Requirement R3.

Dpcs and flexible cavity trays should be of the correct dimensions to suit the detailed design.

For complicated junctions, preformed cavity trays are recommended. Care should be taken to order the correct type and shape.

**(b) flashings**

The following are acceptable as flashings:

- rolled lead sheet (at least Code 4) complying with BS EN 12588
- aluminium and aluminium alloys complying with BS 1470 (0.6mm to 0.9mm thick)
- zinc alloy complying with BS 6561 and 0.6mm thick.

**WALL TIES****6.1 - M7 Wall ties shall be appropriate for their location and intended use**

Wall ties shall be in accordance with either:

- BS EN 845, or
- an assessment in accordance with Technical Requirement R3.

Ties should be long enough to be embedded at least 50mm into each leaf.

In England and Wales, wall ties should be stainless steel or non-ferrous. In Northern Ireland, stainless steel or non-ferrous ties should be used where the cavity is fully filled with insulation and 75mm wide or more. In Scotland, galvanised ties may be used.

Where partial cavity insulation is used, it should be held in place by retaining devices which may be clipped to the wall ties. These devices should be assessed in accordance with Technical Requirement R3 and used only with compatible wall ties.

**LINTELS****6.1 - M8 Lintels shall be of the type and dimensions appropriate to their position within the structure**

Steel and concrete lintels should comply with BS EN 845-2, 'Specification for ancillary components for masonry'.

Lintels up to 1.2m length which do not need a separate dpc tray should have a minimum 100mm end bearing and project beyond the cavity closer by at least 25mm. Normally, other lintels should be long enough to have a minimum 150mm end bearing each side of the opening.

Cavity trays may be required over the lintels. This should be specified in the design. Reference should be made to Design clause 6.1 - D9(b).

**THERMAL INSULATION****6.1 - M9 Insulation materials shall provide the degree of insulation to comply with the design**

All retro-fill insulation materials (UF foam, blown mineral fibre and expanded polystyrene beads) should be installed by installers trained by the assessment holder and approved jointly by the assessment holder and the assessing organisation.

The installer should be a member of a surveillance scheme acceptable to NHBC.

Insulation materials should be installed in accordance with the following:

- UF foam to BS 5617 installed in accordance with BS 5618
- all other insulation materials, whether for full or partial cavity insulation, insulated blockwork or internal insulation may only be used if assessed in accordance with Technical Requirement R3.

The thickness of materials required by the design and Appendix 6.1-A should be used.

**CLADDING MATERIALS****6.1 - M10 Cladding materials shall be of the quality, type and dimensions required by the design**

Items to be taken into account include:

**(a) tiles and slates**

Clay tiles for tile hanging should be to BS 402.

Concrete tiles for tile hanging should be to BS 473.

Slates for vertical slating should be to BS 680.

**(b) timber boarding**

Timber should comply with BS 1186 and be Class 3 or better.

Timber should be a naturally durable species or pre-treated with preservative. Reference should be made to Chapter 2.3 'Timber preservation (natural solid timber)' (each section) for guidance on preservative treatments.

**(c) underfelt behind cladding**

Type 1F felt to BS 747 is acceptable as an underfelt behind cladding.

**(d) battens**

Battens should be of the size specified in the design and pre-treated with preservative treatments. Reference should be made to Chapter 2.3 'Timber preservation (natural solid timber)' (each section) for guidance on preservative treatments.

**(e) proprietary cladding systems**

Proprietary systems should be assessed in accordance with Technical Requirement R3.

**MOVEMENT JOINTS**

**6.1 - M11 Materials for movement joints shall be suitable for their intended purpose**

When choosing materials, account should be taken of the following:

- joint width
- joint depth
- anticipated movement
- movement capability of material
- surface preparation
- backing materials
- projected life span of joint.

Acceptable materials for movement joints in clay brick walls are:

- flexible cellular polyethylene
- cellular polyurethane
- foam rubber.

Materials which are acceptable for use in contraction joints with concrete bricks or blocks, but not acceptable for use as expansion joints in fired clay bricks, are:

- hemp
- fibreboard
- cork.

In concrete blockwork, the construction joint may be a simple vertical joint filled with mortar and sealed.

**SITWORK STANDARDS**

**6.1 - S1 All sitework shall:**

- (a) meet the Technical Requirements**
- (b) take account of the design**
- (c) follow established good practice and workmanship**

Sitework that complies with the design and the guidance below will be acceptable for external masonry walls.

**CONSTRUCTION**

**6.1 - S2 Construction shall ensure a satisfactory standard of brickwork and blockwork**

Items to be taken into account include:

**(a) appearance**

The appearance of a masonry wall depends upon the materials used, the setting out and the workmanship. Further details are given in Clauses S2 to S10.

**(b) setting out**

When setting out masonry, avoid cutting bricks or blocks except when it is essential and avoid irregular or broken bonds, particularly at openings.

Where a number of openings of similar width are being formed, use a rod cut to the required size to check the width of openings as the work rises.

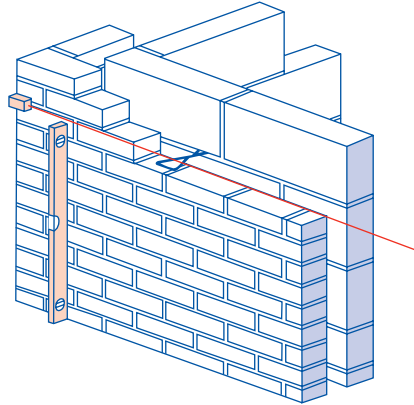

To keep courses to the correct height, use a gauge rod. The rod should be marked with the height of windows, doors and floors.

All work should be reasonably level and true. The bond detailed in the design should be used. Perpendicular joints should be kept in line and plumb. Courses should be kept level by using lines and spirit levels.

**(c) mortar**

Different types of bricks and blocks need different strength mortar mixes. Some parts of the building, such as below dpc, chimneys and copings, may need a different mix to the main walling. Make sure the mix is right for the job.

Recommended mortar mixes are given in Appendix 6.1-C.

Plant and banker boards should be kept clean. Mixers should be kept clean to operate efficiently. The mortar colour should be consistent.

Mortar which has started to set should not be re-tempered.

All bricks and blocks should be laid on a full bed of mortar and all perpend should be solidly filled.

Joints should be filled to reduce the risk of rain penetration and dampness in the wall. Solid mortar bedding and fully filled perpend are particularly important in exposed areas and where the cavity is to be fully filled with insulation.

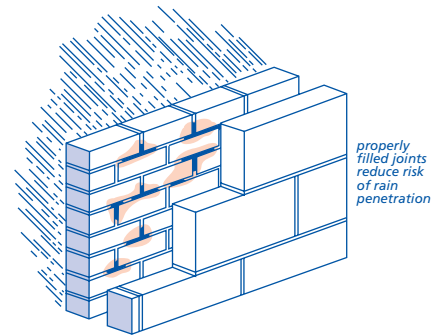

Unless the design states otherwise, only bucket handle or weathered joints should be used. Recessed joints should not be used where the cavity is to be fully filled with insulation.

Where pigments (to BS 1014) are used they should not exceed 10% of the cement weight or 3% if carbon black is used.

For precautions to take in cold weather, reference should be made to Chapter 1.4 'Cold weather working'.

**(d) cavity walls**

Cavities should be uniform and of the width specified in the design. All cavities should be at least 50mm nominal clear width. Partial cavity insulation should be fixed against the inner leaf of the cavity. Check that the correct wall tie is being used (reference should be made to Clause S5).

To keep the wall plumb, do not over-reach at changes of lift. It is better to wait for the next scaffolding lift.

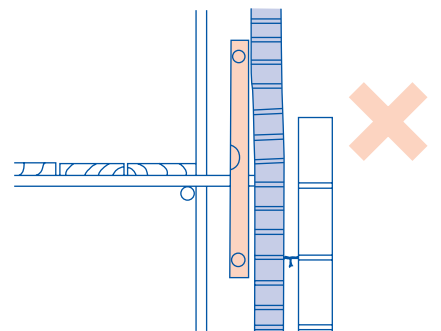

The difference in heights between the two leaves of a cavity wall under construction can be up to 6 block courses, provided the ties are sufficiently flexible to ensure coursing is achieved without breaking the bond.

Cavities should be constructed so that:

- mortar is struck off from all joints as work proceeds
- wall ties are kept free of droppings and debris
- cavity trays are clear of droppings and debris.

# 6.1

## External masonry walls

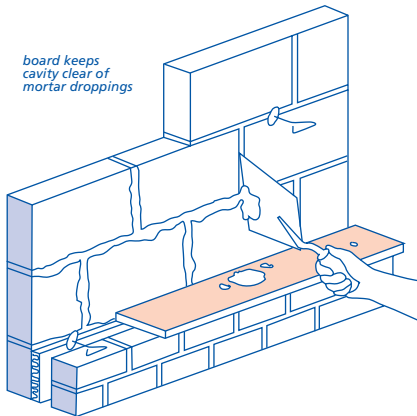

Clean cavities with mortar droppings removed are particularly important in exposed areas and where partial cavity fill is used.

Where cavity insulation is used, mortar droppings should be cleaned off from the top edge. Mortar left on the top edge may transmit dampness to the inner leaf. The use of a cavity batten will prevent this. Cavity battens should be wrapped with flexible material to allow easy withdrawal.

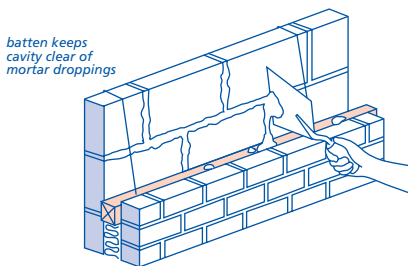

### (e) movement

Brickwork/blockwork should not be subjected to vibration until the mortar has set.

### (f) openings

Masonry may be built around either:

- the frame in-situ, or
- a profile or template to enable the frame to be fitted later.

Openings should be the correct size and square. The brickwork should butt closely against the frame. The frame should not be distorted by forcing bricks against the jamb.

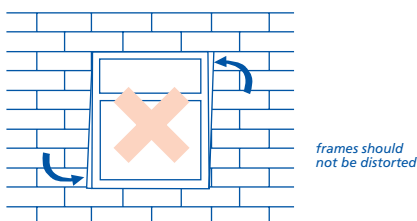

Window and door frames, when built-in, should be fixed with:

- frame cramps, or
- proprietary cavity closers, or
- plugs and fixings.

Timber plugs should not be used in vulnerable positions, such as the outer leaves of walls.

### (g) bonding

A regular bonding pattern should be maintained. External walls should be bonded to partitions and party walls, as required by the design. Either:

- tooth every alternate course, or
- tie with wall ties, expanded metal or equivalent at centres not exceeding 300mm vertically.

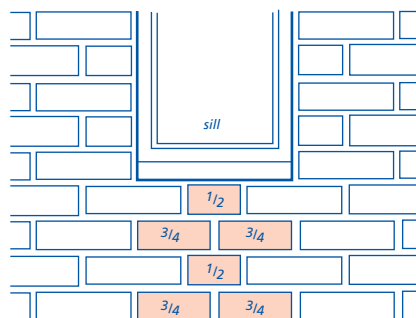
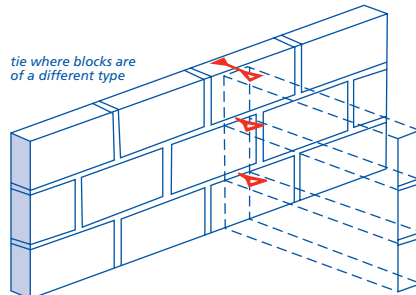
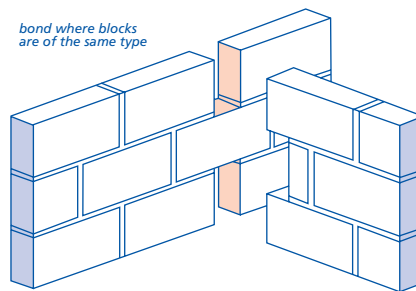

Where joist hangers are not used, joist filling should be brick or blockwork, without excessive mortar joints. Clay bricks and concrete blocks should not be mixed. Joist filling should be kept 12mm below the top of flat roof joists to allow for timber shrinkage, but check also that cold roof ventilation is not blocked (reference should be made to Chapter 7.1 'Flat roofs and balconies' (Design and Sitework)).

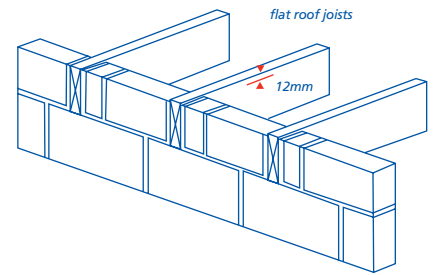

Where a different size of masonry unit is needed to ensure correct coursing, small units of the same material should be used to reduce cracking and problems due to different thermal insulation properties.

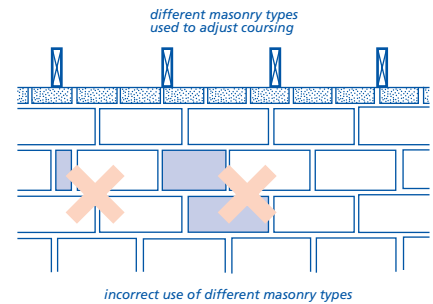

Where the inner leaf of a cavity wall is being used for thermal insulation and where a different size of masonry unit is used to ensure correct coursing, the unit should have similar thermal insulation properties to the masonry used for the rest of the wall. For example aerated concrete blocks should not be mixed with clay bricks.

### (h) chasing for services

Chases should be cut with care. Impact power tools can damage the wall and should not be used.

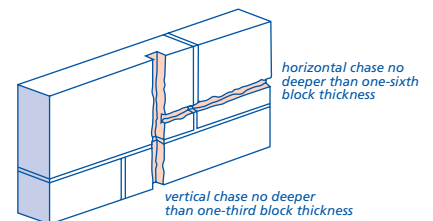

The depth for horizontal chases should be limited to one-sixth of the thickness of the single leaf. The depth for vertical chases should be limited to one-third of the thickness of the single leaf. Hollow blocks should not be chased unless specifically permitted by the manufacturer.

### (i) movement joints

Movement joints should be formed where required by the design. Movement joints are necessary in long lengths of walling to reduce unsightly cracking. Joints are often hidden in corners, or behind rainwater pipes.



The correct materials should be used to form movement joints. Clay bricks expand and require an easily compressible material.

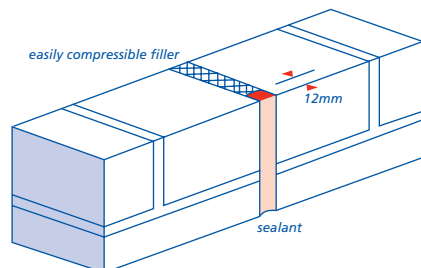

Suitable materials are:

- flexible cellular polyethylene
- cellular polyurethane
- foam rubber.

The sealant should be at least 10mm deep to ensure a good bond. If the joint is in a freestanding wall, the filler will require sealant to both exposed edges and the top (where the joint is carried through the coping).

### (j) corbelling

Where courses are corbelled out in ordinary masonry, one above another, the extent of corbelling should not exceed that shown in the following diagrams.

Where reinforcing is used, corbels should be designed by an Engineer in accordance with Technical Requirement R5.

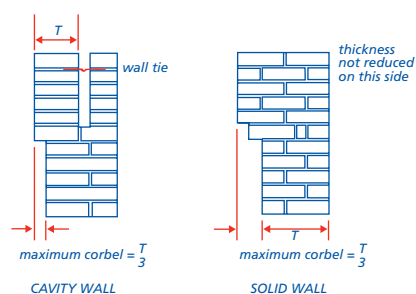

### (k) calcium silicate bricks

Where calcium silicate bricks are used, the brick manufacturer's recommendations should be followed.

## STONE MASONRY

### 6.1 - S3 Stone masonry shall be constructed to an acceptable standard

Stone masonry will be acceptable if it:

- complies with brickwork/blockwork clauses (where appropriate)
- gives an adequate weather-resisting structure (in conjunction with any brick or block backing and/or vertical damp-proof membranes)
- is prepared and laid on its natural bed (unless local practice is otherwise)
- follows good local recognised practice.

## DAMP-PROOF COURSES AND CAVITY TRAYS

### 6.1 - S4 Dpcs and cavity trays shall be installed to prevent moisture entering the building

Items to be taken into account include:

#### (a) horizontal dpcs

Dpcs and cavity trays should be in one continuous piece, whenever possible. Joints in horizontal wall dpcs positioned to prevent rising damp should be lapped 100mm or sealed or welded. The manufacturer's recommendations should be checked. Elsewhere, joints in dpcs and cavity trays should be sealed to prevent water seeping through the joints.

At ground level, all parts of the dpc should be at least 150mm above finished ground or paving level.

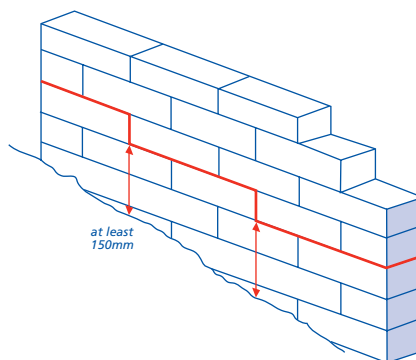

Special dpc detailing may be required at doorways where the dwelling is to be designed to allow access for the disabled.

Dpcs should:

- be laid on a surface, free from projections which could puncture or adversely affect the dpc material
- be fully bedded on fresh mortar where required by the design, or where the building is over three storeys in height
- be of correct width
- not project into the cavity
- not be set back from the edge of the masonry
- lap the dpm.

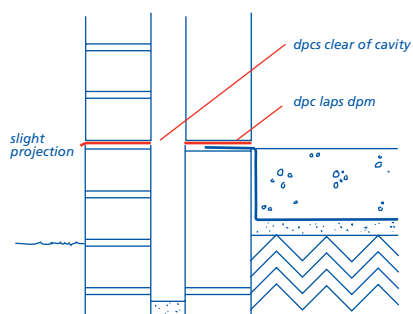

The concrete fill in a cavity wall should stop at least 225mm below the base dpc. This may be reduced to 150mm where special foundations, such as rafts, are used.

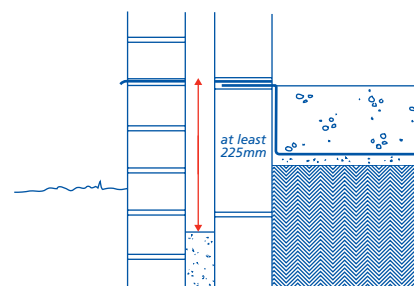

#### (b) dpcs in parapet walls

Parapet walls should have:

- a dpc under the coping, and
- a dpc tray starting 150mm minimum above the roof.

The coping throating should be clear of the brickwork. Reference should be made to Clause S4(d) for guidance on sealing dpcs.

All dpcs should be fully bedded in mortar.

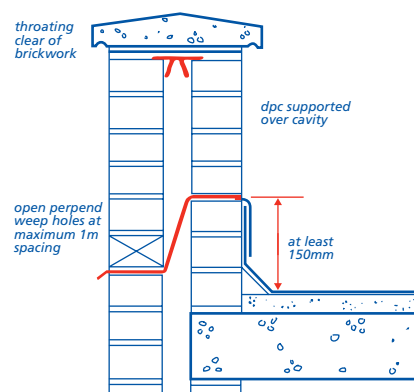

#### (c) dpcs to prevent downward flow of water

Where dpcs are intended to prevent the downward movement of water, joints should be sealed or welded. Lapped joints, unsealed, are unacceptable.

Where flashings link with dpcs, rake out 25mm of mortar *below* the dpc to allow for the flashing to be tucked in. It is easiest to rake out the joints as the work proceeds.

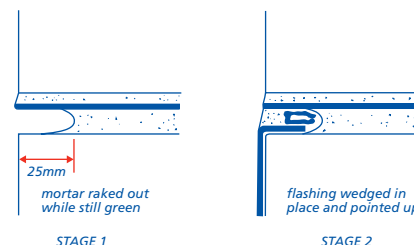

#### (d) dpcs around openings

A dpc (either separate or combined as part of a proprietary cavity closer) should be provided at jambs of openings and at heads and sills as required by the design.

# 6.1

## External masonry walls

Where a jointed or permeable sill is used (all sills in Northern Ireland and the Isle of Man), a dpc should be placed between the sill and the outer leaf, turned up at the back and ends of the sill.

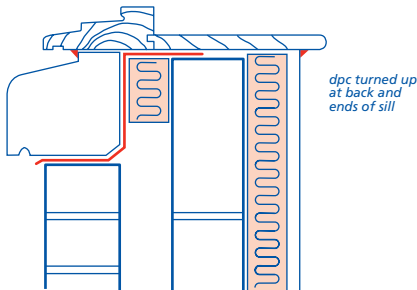

Where a separate vertical dpc is used it should be 150mm wide and be nailed to the full height of the frame. The dpc should protrude into the cavity by about 25mm and extend up to the underside of the lintel where it should be turned back towards the inner leaf.

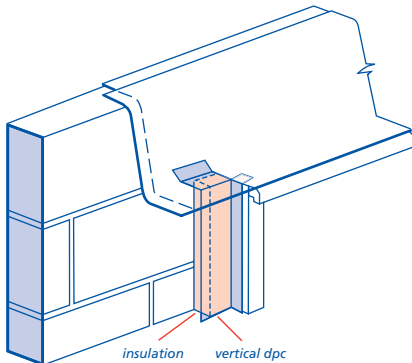
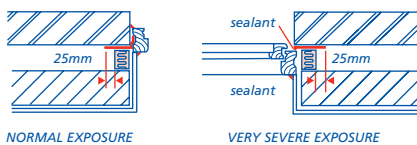

Where there is a sill dpc, it should be lapped with the reveal dpc.

If there is no sill dpc, the vertical dpc should be continued 150mm below the sill level.

A fillet joint of sealant should not be considered as a substitute for good workmanship or dpcs. However, a bead of mastic should be used around openings.

### (e) cavity trays

The single brick thick external leaf of a cavity wall can allow moisture into the cavity. Cavity trays should be used so that water drains outwards above openings.

Cavity trays over lintels should extend at least 25mm beyond the outer face of the cavity closer and cover the ends of the lintel. Where the lintel does not require a dpc, the lintel itself should have a suitable profile and durability and give complete

protection to the top of the reveal and vertical dpc where provided.

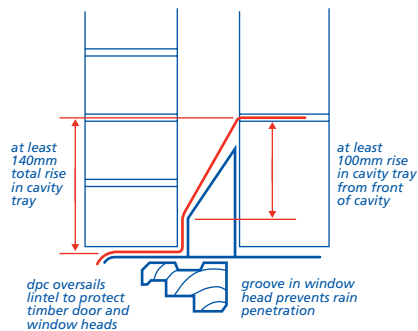

The upstand part of the cavity tray should be returned into the inner leaf masonry unless stiff enough to stand against the inner leaf without support.

In Scotland, all lintels should have a dpc built into the inner leaf.

In Scotland, Northern Ireland, the Isle of Man and areas of Very Severe exposure to driving rain, the upstand part of the damp-proof protection should be returned into the inner leaf of masonry.

Where fairfaced masonry is supported by lintels:

- weep holes should be provided spaced at maximum 450mm intervals. Each opening should have at least two weep holes.
- cavity trays or combined lintels should have stop ends.

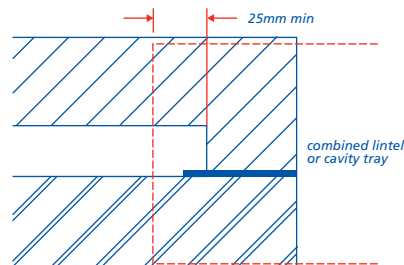
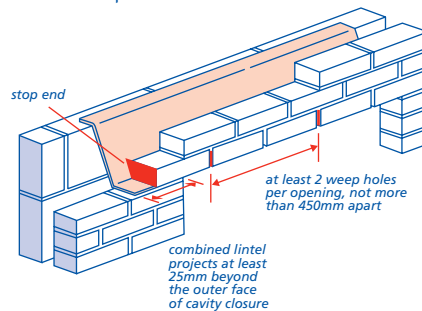

A cavity tray should be provided where the cavity is bridged by air bricks, etc. The dpc should extend 150mm beyond each side of the bridge.

Where not otherwise protected (eg by a roof at an appropriate level), a dpc tray should be provided over meter boxes.

A dpm should be provided behind meter boxes in areas of very severe exposure to driving rain.

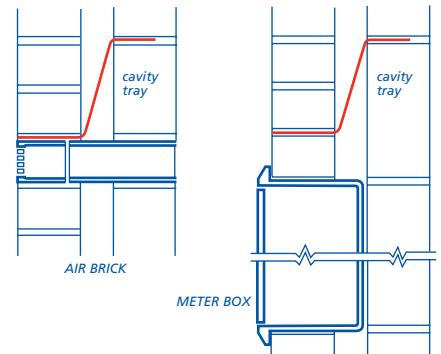

### (f) stepped cavity trays

At the abutment of pitched roofs to cavity walls, preformed stepped cavity trays should be provided as shown below. The lowest cavity tray should have two stop ends and a weep hole to allow water to drain from the cavity.

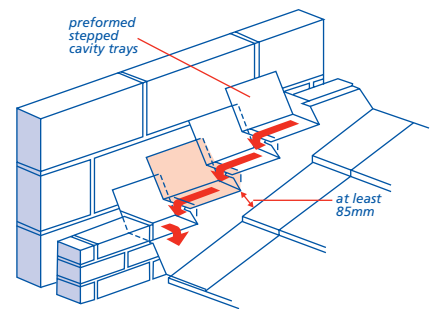

## WALL TIES

### 6.1 - S5 Wall ties shall be of the correct type correctly installed

Items to be taken into account include:

#### (a) type

The type of wall tie specified by the designer should be used.

#### (b) position

If ties slope down to the inner leaf, if drips are off-centre or if ties have mortar droppings on them, water can cross the cavity.

The two leaves should be coursed so that the wall tie is level or slopes outwards.

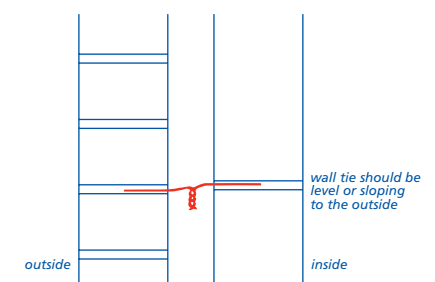

Ties should be bedded a minimum of 50mm into each leaf of the wall as work

proceeds. The drip should face downwards. Ties should be built-in, not pushed into joints.

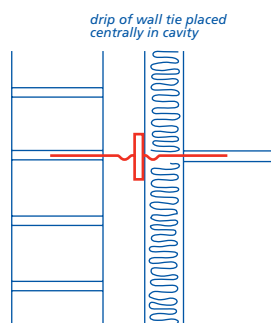
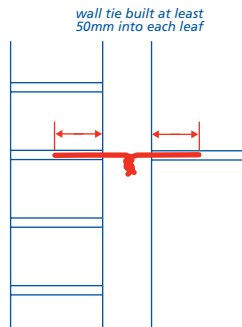

Where one leaf is built in advance of the other, the wall ties should project enough from the built leaf to bed at least 50mm into the unbuilt leaf.

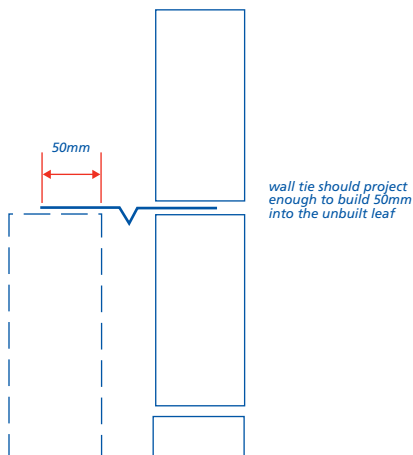

### (c) spacing

Wall ties should be spaced above and below dpc as follows:

	Maximum spacing (mm)	
	Horizontally	Vertically
General wall area	900	450
At jamb openings, movement joints, etc.	within 225 of opening	not more than 300

At openings and movement joints, wall ties should be spaced at maximum 300mm centres vertically even if this means cutting cavity insulation to insert the tie.

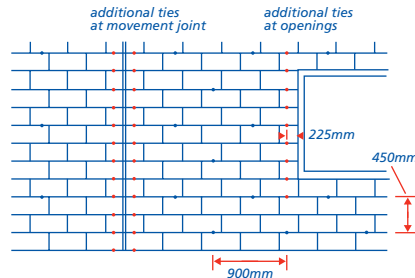

### (d) use of partial fill insulation

Where partial cavity fill insulation is being used, it should be retained against the inner leaf by retaining devices. The retaining devices should be compatible with the wall ties and used in accordance with an assessment which complies with Technical Requirement R3.

Unless the independent assessment states otherwise, where partial cavity fill is being used the wall ties should be spaced more closely to provide adequate support and restraint for the 1200mm long boards. Ties should be spaced at 600mm centres horizontally and in vertical as well as horizontal rows, ie not staggered.

## LINTELS

### 6.1 - S6 Lintels and beams shall be installed correctly

Items to be taken into account include:

#### (a) span and placing

Lintels should be the correct size for the opening and have the correct bearing at each end:

Span (m)	Minimum bearing length (mm)	
	Simple lintel	Lintel combined with cavity tray
Up to 1.2	100	150
Over 1.2	150	150

Longer span lintels may require padstones (the design should be checked).

Setting out should ensure that lintels bear on a full block, where possible, or on a whole brick, and be installed level on a solid bed of a mortar. Soft or non-durable packing should not be used. Small pieces of cut brick or block should not be used around lintel bearings.

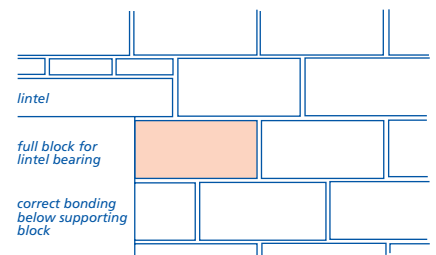

Lintels and masonry should form openings of the correct size for the frame of the window or door.

Concrete floor units or other heavy components which bear on lintels should be positioned carefully to avoid damage or shock load.

The lintel toe should:

- project past the window head
- have a flexible sealing compound between toe and window.

Brickwork or masonry should not overhang the lintel by more than 25mm.

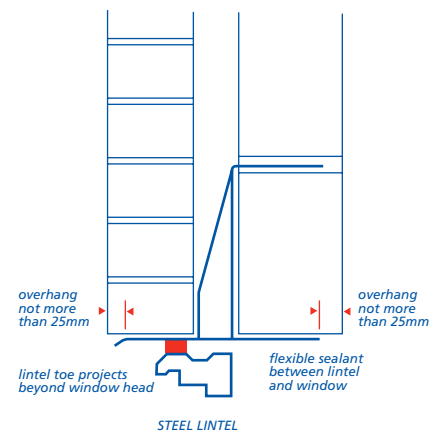

#### (b) thermal insulation

Insulation may help to prevent cold bridges at the heads of openings in external walls. The design should be checked for this requirement. Insulation should be provided to the underside of the lintel unless the manufacturer shows an alternative to prevent cold bridging.

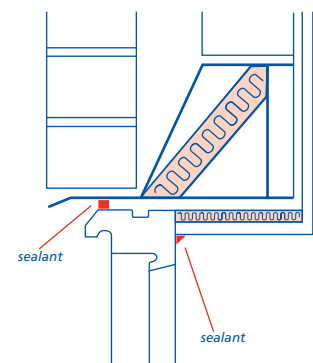

#### (c) use of dpc cavity trays

A separate cavity tray should be provided over some lintels if:

# 6.1

## External masonry walls

- the corrosion protection to the lintel is inadequate, and
- the shape of the lintel is unsuitable.

This should be checked with the designer or buyer.

In Scotland, Northern Ireland, the Isle of Man and areas of *Severe* or *Very Severe* exposure to driving rain, a cavity tray is required over all lintels. Reference should be made to Clause S4(e) for details of cavity trays.

All cavity trays should have stop ends where the outer leaf is fairfaced masonry.

### (d) use of steel lintels

Where steel lintels are being used, the inner and outer leaf should be built up together to avoid twisting the lintel flange. The difference in height between the leaves should not exceed 225mm.

## THERMAL INSULATION

### 6.1 - S7 Thermal insulation shall be installed correctly

A high standard of workmanship should be maintained to minimise the risk of damp penetration to the inside of the dwelling where cavity insulation is used.

In particular:

- mortar joints, including perpend, should be solidly filled with mortar
- mortar droppings should be removed from wall ties and the edges of insulation materials
- excess mortar should be struck smooth from the inside of the outer leaf.

Where insulation is built-in, manufacturers' instructions should be followed. These are normally printed on the insulation packaging and include a recommended sequence of construction.

Recessed joints should not be used where the cavity is to be filled with insulation.

In Northern Ireland and the Isle of Man it is not permissible to fill the cavity with pumped insulants, eg UF foam, at the time of construction.

In Scotland, it is not permissible to fill the full width of the cavity with any thermal insulants at the time of construction.

All retro-fill insulation materials (UF foam, blown mineral fibre and expanded polystyrene beads) should be installed by installers trained by the assessment holder and approved jointly by the assessment holder and the assessing organisation. The installer should be a member of a surveillance scheme acceptable to NHBC.

The first row of insulation boards or batts should be supported on wall ties, two ties to each board or batt.

Wall ties should coincide with horizontal joints in the insulation.

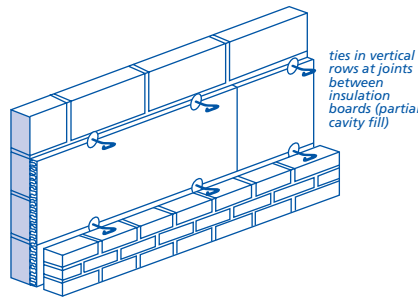

Where wall ties need to be closely spaced, for example at reveals, it is acceptable to make a clean cut neatly in the insulation to accept the extra ties. The insulation manufacturer's instructions should be followed.

Insulation should be close butted with no gaps. Gaps provide routes for dampness, and condensation can form on the cold spots where insulation is missing.

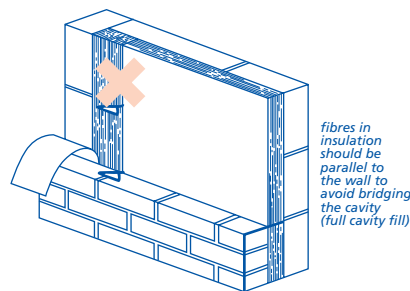
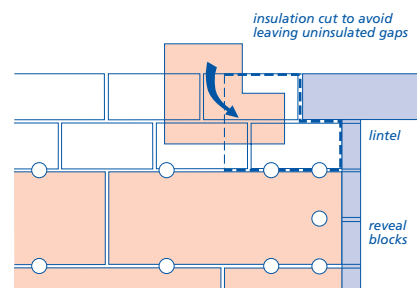

Insulation boards for partial fill should be stored flat without bearers otherwise they may distort making them difficult to fix against the wall. Warped boards should be rejected.

## RENDERING

### 6.1 - S8 Rendering shall be to the correct mix, have a good bond and be free from significant cracking and crazing

Items to be taken into account include:

#### (a) preparation of backing surface

The surface to be rendered should be free from dust, loose particles, efflorescence and organic growth.

Where necessary, surfaces should be treated to provide an adequate key by:

- raking out joints

- hacking the surface
- applying a bonding agent
- applying metal lathing
- applying a spatterdash coat, or
- other appropriate means.

The surface suction should be checked by splashing water onto the wall. The result should be observed and appropriate action taken as follows:

- if too much suction, spraying with water may be needed - do not use too much water
- if too little suction, a spatterdash coat or bonding agent may be needed
- if the background is too wet, delay rendering until conditions improve.

The design requirements should be checked where rendering is continuous over different materials. Corrosion-resistant metal lathing should be fixed across the joints or, alternatively, provision made to accommodate movement.

Expanded metal should be fixed with the correct side towards the wall (see manufacturers' literature). If metal lathing is used to bridge changes in background material, a separating strip, eg breather paper, should be fixed behind the lathing so that the render does not bond at the background joints. Lathing should be set away from the wall so that rendering can be forced through the mesh to achieve a good bond.

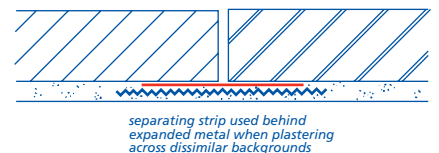

### (b) mix

The mix proportions should be checked against the specification, especially whether sulfate-resisting cement should be used.

Mixes for rendering on brickwork using clay bricks with no limit on their soluble salt content (F2,S1 or F1,S1 to BS EN 771) should be as follows:

Exposure conditions	Undercoat mix proportions (by volume)	Finishing coat mix proportions (by volume)
Parapets, freestanding walls, pillars, retaining walls and chimneys	rendering not recommended	
All walls other than those above	1 : 5, sulfate-resisting Portland cement : sand, plus integral waterproofer	1 : 5, ordinary Portland cement : sand, dry dashing strongly advised

For backing brickwork, it should be



ensured that sulfate-resisting cement which complies with Appendix 6.1-C is used in the mortar.

If water-resisting properties are required, Portland cement with a waterproofing agent already incorporated may be available. Otherwise, a waterproofing agent should be used and added to the rendering mix in strict accordance with manufacturers' instructions.

### (c) application

The number and thickness of coats should be in accordance with the design.

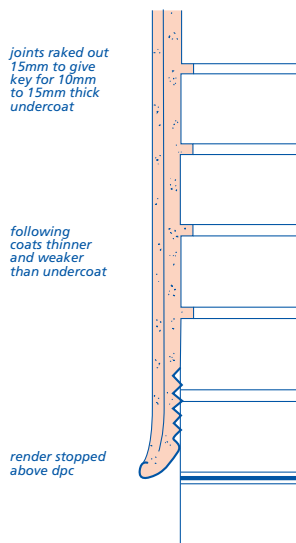

In Scotland, a spatterdash coat should be applied before the first render coat if the background is of Scottish common bricks and bricks to BS EN 771.

Undercoats should be applied at least 3 days before applying the following coat.

If coloured pigments are specified, batching should be undertaken with care to ensure colour consistency.

### (d) cracking and crazing

Rendering should be free from significant cracking and crazing.

To avoid surface crazing:

- use properly graded sand (fine sand increases the risk of crazing)
- strong mixes should not be used as the finishing coat
- overworking, which causes laitance to be drawn to the surface, should be avoided
- the finishing coat should be kept damp for at least 3 days. In warm dry weather, spraying or protection by polyethylene sheet may be needed. Rendering should not be carried out during hot weather or in bright sunshine.

## COLD WEATHER WORKING

**6.1 - S9 Precautions shall be taken to protect walls and rendering from damage by frost during construction**

Freshly laid mortar and render may fail if it freezes because the frozen water expands and forces apart the particles of mortar.

Admixtures which contain calcium chloride should not be used.

The use of air entraining agents in cold weather gives better frost resistance to set mortar but does not aid the set. The use of accelerating admixtures and other admixtures should not be relied on as an anti-freeze precaution.

Check what effect additives have on setting times. Cold weather slows setting, as do retarders. If the set is retarded too much, the next lift might squeeze out the mortar below.

Brick and blockwork should not be built nor rendering carried out when the air temperature is 2°C and falling.

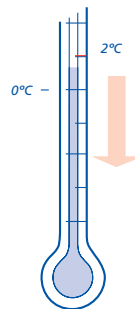

Walls should be protected from frost until the mortar has set sufficiently to resist frost damage. Covers should be provided to form a still air space to insulate the wall. Walling damaged by frost will not regain strength and should be taken down and re-built when conditions improve.

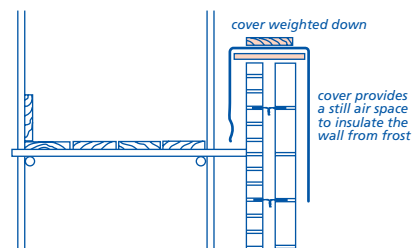

Reference should be made to Chapter 1.4 'Cold weather working' for more detailed advice.

## HANDLING AND PROTECTION

**6.1 - S10 Materials shall be handled, stored, used and protected in such a way as to ensure that the construction shall be neat, clean and undamaged upon completion**

Items to be taken into account include:

### (a) avoidance of damage

It is cost effective to protect and store materials properly and maintain good quality control during construction.

### (b) handling

The unloading of all bricks and blocks, especially facing bricks, preferably should be by mechanical means, directly onto a firm level surface. Bricks that are tipped on delivery or moved about the site in dumper trucks often have a high degree of wastage. Chipped or fractured bricks are not acceptable for facework.

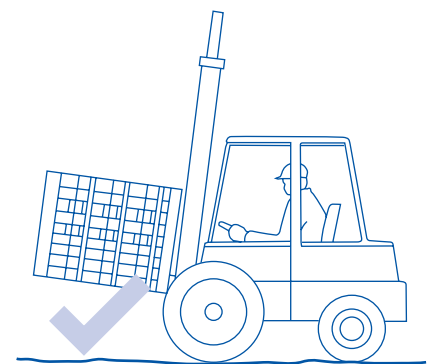
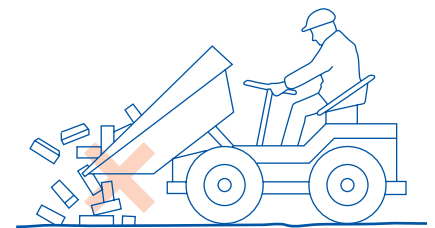

### (c) storage

Stacks of bricks and blocks should be protected from rain, mud splashes, etc by covering with waterproof covers. Bricks and blocks that become excessively wet can suffer from:

- staining and efflorescence
- increased drying shrinkage with a greater risk of cracking
- lack of mortar adhesion to mud stained surfaces.

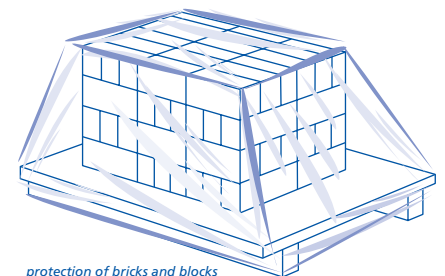

Cement should be stored off the ground and protected from weather. Sand should be prevented from spreading and be protected so that it remains clean.

The work place should be kept clean to reduce mortar splashes to a minimum. Any accidental mortar smears should be lightly

# 6.1

## External masonry walls

brushed off the face after the mortar has taken its first set.

### (d) workmanship

Materials should be handled with care during construction to avoid damage and staining. Badly chipped bricks should not be used for facework.

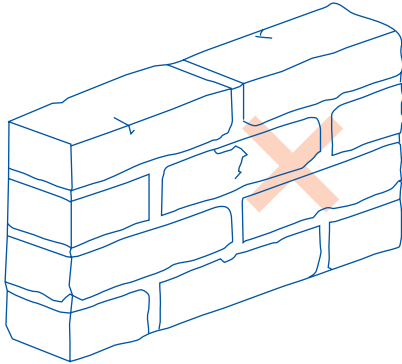

Unless bricks have been blended by the manufacturer, bricks from different batches should be mixed to avoid colour patching.

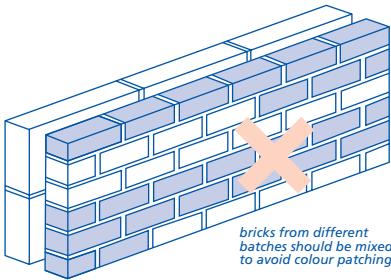

To reduce the risk of efflorescence, newly erected masonry should be covered. This also prevents the mortar being washed out of the joints by rain and stops masonry becoming saturated.

## APPENDIX 6.1-A

### Suitable wall constructions for use with full cavity insulation

Exposure category	Suitable wall construction	Minimum insulation thickness (mm)		
		Built-in insulation	Retro-fill (other than UF foam)	UF foam
<b>Very Severe</b>	Any wall with impervious cladding	50	50	50
	Fairfaced masonry with impervious cladding to all walls above ground storey	100	100	N/A
	Any wall fully rendered <sup>2</sup>	75	75	N/A
<b>Severe</b>	Fairfaced masonry <sup>1</sup>	N/A	N/A	N/A
	Any wall with impervious cladding or render <sup>2</sup>	50	50	50
	Fairfaced masonry with impervious cladding or render <sup>2</sup> to all walls above ground storey	50	75	50
<b>Moderate</b>	Fairfaced masonry	75	75	N/A
	Any wall with impervious cladding or render	50	50	50
	Fairfaced masonry with impervious cladding or render to all walls above ground storey	50	50	50
<b>Sheltered</b>	Fairfaced masonry	50	75	75
	Any wall with impervious cladding or render	50	50	50
	Fairfaced masonry with impervious cladding or render to all walls above ground storey	50	50	50
	Fairfaced masonry	50	50	50

N/A - not applicable

### Notes

- 1 In *Very Severe* exposure locations fairfaced masonry with full cavity insulation is not permitted.
- 2 Render on an external leaf of clay bricks (F2,S1 or F1,S1 designation bricks to BS EN 771) in *Severe* or *Very Severe* exposures is not permitted where the cavity is to be fully filled with insulation.
- 3 This table covers walls where the external leaf does not exceed 12m in height.
- 4 The exposure category of the dwelling is determined by its location on the map showing categories of exposure to wind driven rain.
- 5 Fairfaced masonry includes clay, calcium silicate and concrete bricks and blocks and dressed natural stone laid in an appropriate mortar (see Appendix 6.1-C) preferably with struck or weathered or bucket handle joints. Cavity walls of random rubble or random natural stone should not be fully filled.
- 6 Recessed mortar joints should not be used.
- 7 In Scotland, it is not permissible to fill the full width of the cavity with any thermal insulation at the time of construction.
- 8 In Northern Ireland and the Isle of Man it is not permissible to fill the cavity with pumped thermal insulants (for example, UF foam) at the time of construction.

MAP SHOWING CATEGORIES OF EXPOSURE TO WIND DRIVEN RAIN

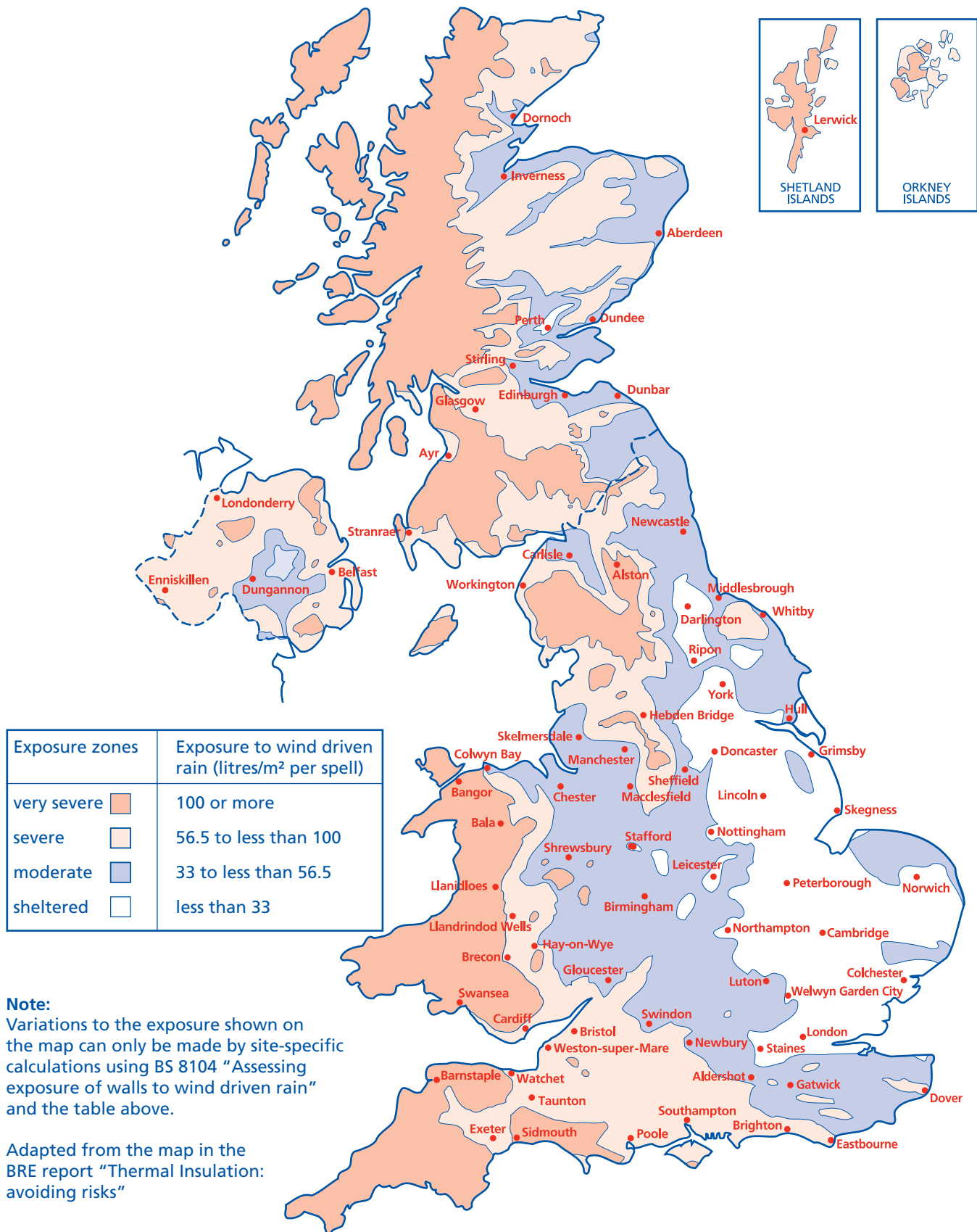

6.1

# 6.1

## External masonry walls

### APPENDIX 6.1-B

#### Areas of severe exposure to frost attack

The tinted areas have a frost incidence over 60 days a year, rainfall over 1000mm per year and an elevation over 90m above sea level.

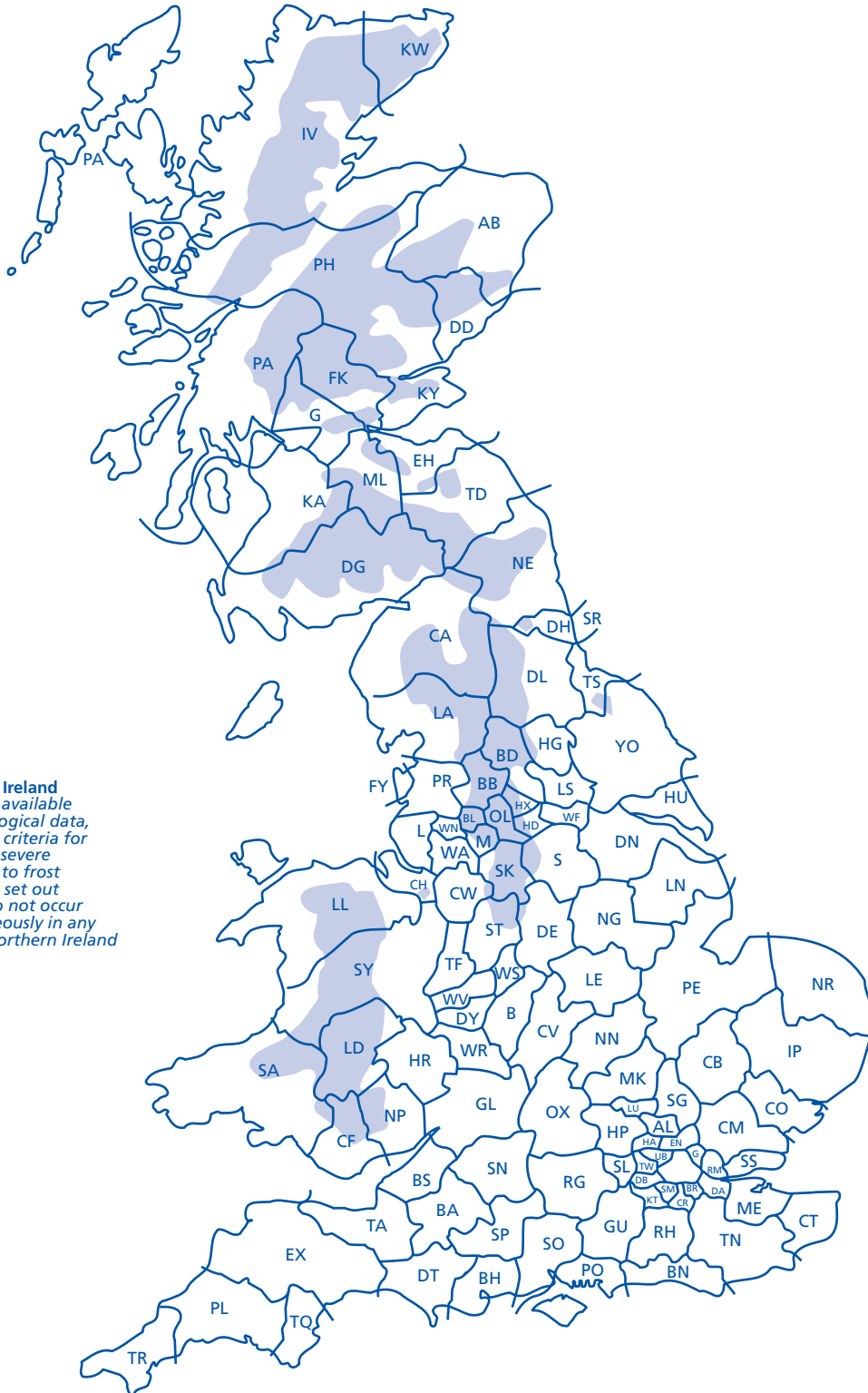

**Northern Ireland**  
From the available meteorological data, the three criteria for assessing severe exposure to frost attack, as set out above, do not occur simultaneously in any part of Northern Ireland

Map reproduced by permission of Hanson.

The following list identifies the postal areas within which the three criteria for severe exposure to frost attack are met. Only in a few instances is the whole of the post code district within the area of severe frost exposure.

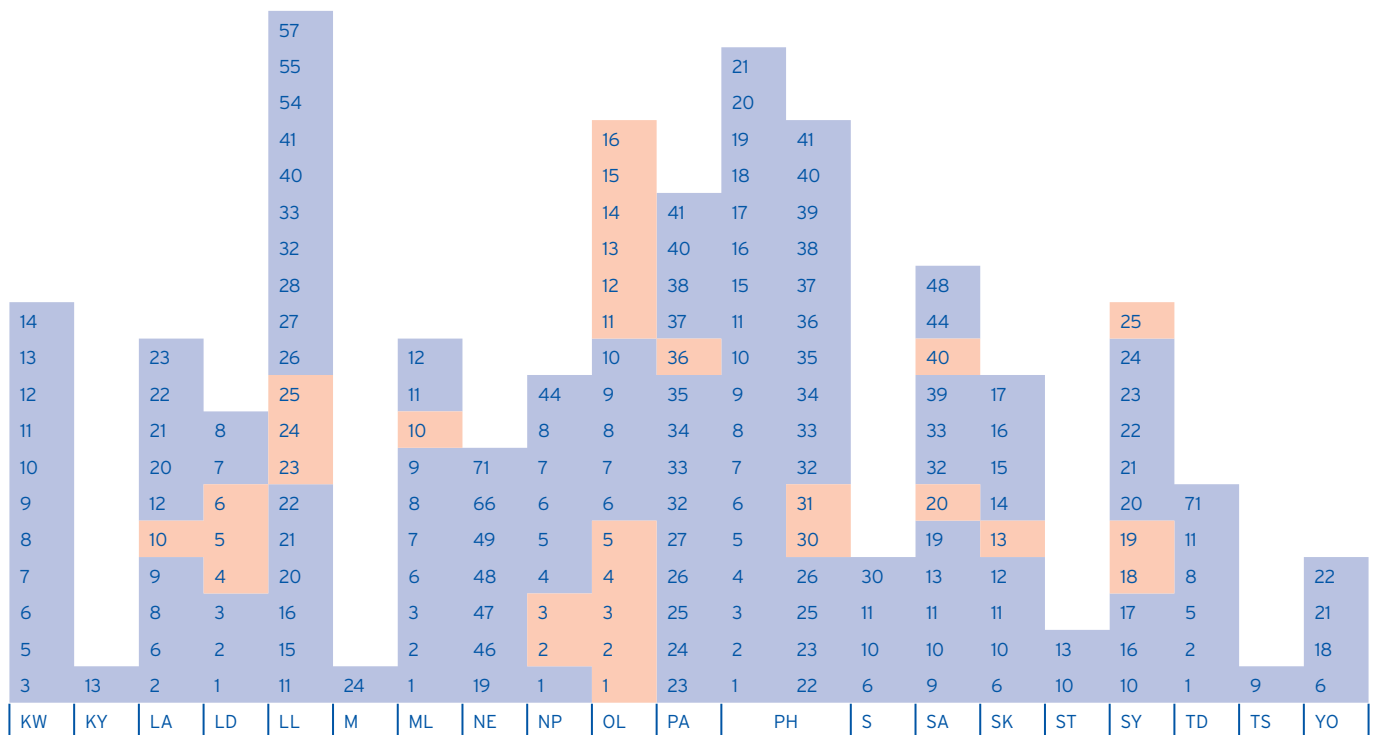
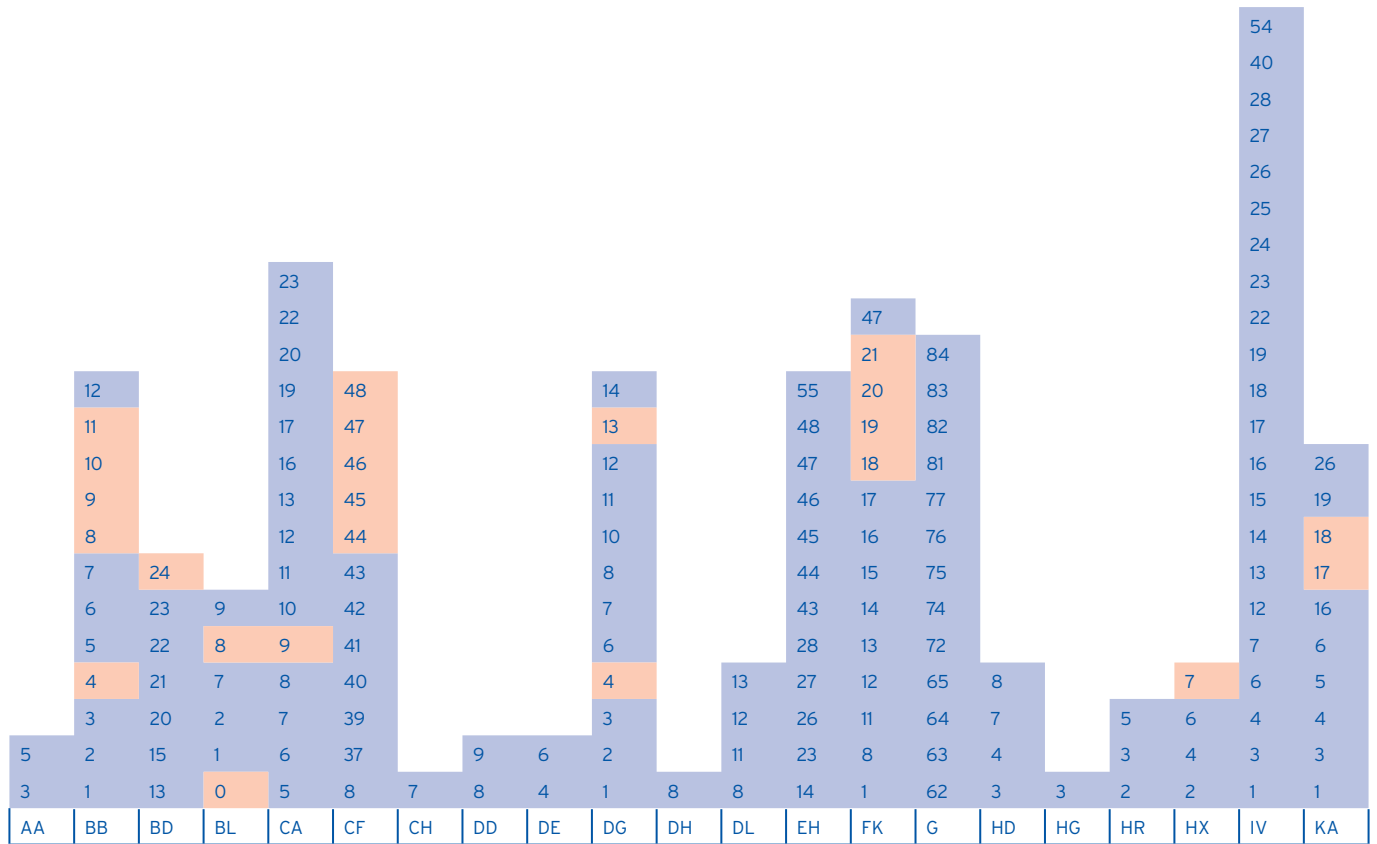

partly within  
wholly within

Reproduced by permission of the London Brick Company Ltd.

## APPENDIX 6.1-C

**Mortar mixes**

Unless recommended otherwise by the brick manufacturer, the mixes in the table below should be used for clay bricks.

In the case of concrete or calcium silicate bricks, particular attention should be paid to manufacturers' recommendations.

**Mortar mixes using ordinary Portland or sulfate-resisting cements where required (see also Design clauses 6.1- D5(b) and (d)).**

Location		Recommended cement: lime: sand mix	Recommended cement: sand mix with air-entraining plasticiser	Recommended masonry cement: sand mix	Mortar designation to BS EN 1996-1-1
General wall area above dpc	in areas of <i>Severe</i> or <i>Very Severe</i> exposure - high durability	1: ½ : 4½	1: 3½	1: 3	(ii)
	other exposure categories - general use	1: 1: 5½	1: 5½	1: 4½	(iii)
Below dpc level and in chimney stacks	- high durability	1: ½ : 4½	1: 3½	1: 3	(ii)
Cappings, copings and sills	- low permeability	1: 0 to ¼ : 3	-	-	(i)

Air-entraining plasticiser can be incorporated in the following general use and high durability mortars:

1: 1: 5½, cement : lime : sand, or

1: 1: 4½, cement : lime : sand.

**Retarded mortar**

Retarded mortar and most pre-mixed mortars can be used over a longer period of time than site mixed, cement : lime : sand mortars. The timescale of use is defined by the manufacturer, whose advice should be followed:

- protect retarded mortar against freezing prior to use
- do not use retarded mortar beyond the time for which it is effective
- because of delayed setting, temporary bracing of larger walls, for example gable peaks and long walls, may be necessary.

**Admixtures and additives**

Where air-entraining plasticisers or other additives are to be used, follow manufacturers' instructions:

- do not overdose, 'more is not better'
- an air entraining agent can help reduce frost damage but it is not an anti-freeze
- do not use unauthorised additives.

APPENDIX 6.1-D

Dpcs and cavity trays

Some positions where dpcs and cavity trays should be provided:

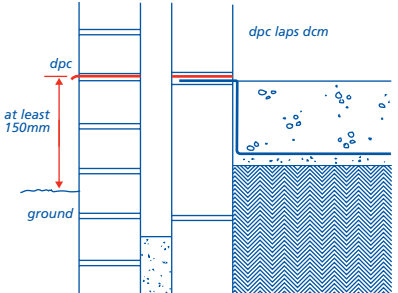
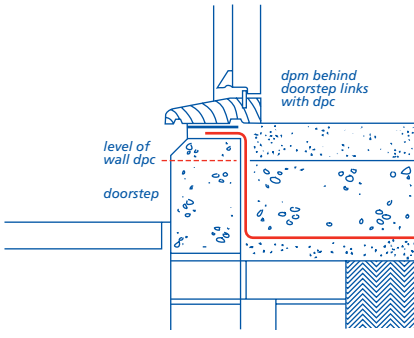
Location	Provision of dpcs and cavity trays
Base of walls, piers, etc	<p>A dpc should be provided a minimum 150mm above adjoining surfaces and linked with the dpm in solid floors.</p> 
Base of partitions built off oversite where there is no integral dpm	<p>Dpc should be full width of partition.</p>
Base of wall built off beam, slab, etc	<p>Detail to prevent entry of damp by driving rain.</p>
Parapet	<p>(1) Beneath coping, and (2) 150mm above adjoining roof surface to link with the roof upstand.</p>
In cavity walls over openings, air bricks and the like	<p>A cavity tray should be provided to direct to the outside any water that enters the cavity. The cavity tray should fully protect the opening.</p>
At the <i>horizontal abutment</i> of all roofs over enclosed areas and balconies to walls	<p>A cavity tray should be provided 150mm above the adjoining roof or balcony surface. The tray should be lapped over any roof upstand or flashing to ensure water penetrating into the cavity does not enter the enclosed area.</p>
At <i>sloping abutments</i> of all roofs over enclosed areas to cavity walls	<p>A stepped cavity tray should be provided above the roof surface and linked to any roof upstand or flashing to ensure any water penetrating into the cavity does not enter the enclosed area.</p>
Doorsteps	<p>A dpc should be provided behind a doorstep where it is higher than a wall dpc.</p> 
Sills	<p>Where precast concrete or similar sills incorporate joints or are of a permeable material, a dpc should be provided beneath them for the full length and be turned up at the back and the end of the sill.</p>
Jambs in cavity	<p>The reveal should be protected throughout its width by a continuous dpc. The width of the dpc should be sufficient to be fixed to, or overlap, the frame and fully protect the reveal.</p> <p>For <i>Severe</i> and <i>Very Severe</i> exposure conditions: rebated reveal construction, with or without closed cavity and dpc.</p>



## APPENDIX 6.1-E

## Durability classification of bricks

BS EN 771-1 classifies clay bricks according to their freeze/thaw resistance and active soluble salts content as follows:

Durability	Freeze/thaw resistance	Active soluble salts content
<b>F2,S2</b>	Freeze/thaw resistant ( <b>F2</b> ), durable in all building situations	Low ( <b>S2</b> )
<b>F2,S1</b>	Freeze/thaw resistant ( <b>F2</b> ), durable in all building situations	Normal ( <b>S1</b> )
<b>F1,S2</b>	Moderately freeze/thaw resistant ( <b>F1</b> ), durable except when saturated and subject to repeated freezing and thawing	Low ( <b>S2</b> )
<b>F1,S1</b>	Moderately freeze/thaw resistant ( <b>F1</b> ), durable except when saturated and subject to repeated freezing and thawing	Normal ( <b>S1</b> )
<b>FO,S2</b>	Not freeze/thaw resistant ( <b>FO</b> ), liable to be damaged by freezing and thawing	Low ( <b>S2</b> )
<b>FO,S1</b>	Not freeze/thaw resistant ( <b>FO</b> ), liable to be damaged by freezing and thawing	Normal ( <b>S1</b> )

Calcium silicate and concrete bricks contain no significant active soluble salts. Information on their durability is given in Materials clause 6.1 - M2(b).

## APPENDIX 6.1-F

## Protection of ancillary components

Selection of ancillary components in relation to material/coating specification for use in buildings up to three storeys in a non-aggressive environment  
(For the full range of product types, materials and details refer to Table 2 of PD 6697:2010)

Product type	EN 845 Ref *	Material/Coating specification (The zinc coating masses are for one surface)
Wall ties conforming to BS EN 845-1	1	Austenitic stainless steel (molybdenum chrome nickel alloys)
	3	Austenitic stainless steel (chrome nickel alloys)
	8 or 9	Zinc coated (940 g/m <sup>2</sup> ) steel wire or component
Tension straps and hangers conforming to BS EN 845-1	1	Austenitic stainless steel (molybdenum chrome nickel alloys)
	3	Austenitic stainless steel (chrome nickel alloys)
	8 or 9	Zinc coated (940 g/m <sup>2</sup> ) steel wire or component
Tension straps and hangers conforming to BS EN 845-1 (internal uses **)	10	Zinc coated (710 g/m <sup>2</sup> ) steel component
	11	Zinc coated (460 g/m <sup>2</sup> ) steel component
	12.1 or 12.2	Zinc coated (300 g/m <sup>2</sup> ) steel strip or sheet with organic coating over all outer surfaces of finished component
	13	Zinc coated (265 g/m <sup>2</sup> ) steel wire
	14	Zinc coated (300 g/m <sup>2</sup> ) steel strip or sheet with all cut edges organic coated
	15	Zinc pre-coated (300 g/m <sup>2</sup> ) steel strip or sheet
	16.1 or 16.2	Zinc coated (137 g/m <sup>2</sup> ) steel strip or sheet with organic coating over all outer surfaces of finished component
	17	Zinc pre-coated (137 g/m <sup>2</sup> ) steel strip with zinc coated edges

Lintels conforming to BS EN 845-2	L3	Austenitic stainless steel (chrome and nickel alloys)
	L10	Zinc coated (710 g/m <sup>2</sup> ) steel component
	L11.1 or L11.2	Zinc coated (460 g/m <sup>2</sup> ) steel component with organic coating over all outer surfaces of finished component
	L12.1 or L12.2	Zinc coated (300 g/m <sup>2</sup> ) steel strip or sheet with organic coating over all outer surfaces of finished component
	L16.2	Zinc coated (137 g/m <sup>2</sup> ) steel strip or sheet with organic coating over all outer surfaces of finished component
Lintels conforming to BS EN 845-2, where used with a separate dpc	L11	Zinc coated (460 g/m <sup>2</sup> ) steel component
	L14	Zinc coated (300 g/m <sup>2</sup> ) steel strip or sheet with all cut edges organic coated
	L16.1	Zinc coated (137 g/m <sup>2</sup> ) steel strip or sheet with allorganic coating over all outer surfaces of finished component
Bed joint reinforcement conforming to BS EN 845-3	R1	Austenitic stainless steel (molybdenum chrome nickel alloys)
	R3	Austenitic stainless steel (chrome nickel alloys)

\* Material /coating reference in accordance with the relevant part of BS EN 845.

\*\* These products are not suitable for use in contact with the outer leaf of an external cavity wall or a single leaf cavity wall.

It is an NHBC recommendation that components in contact with, or embedded in, an inner leaf which is damp or exposed to periodic wettings (eg below dpc) should be protected in the same way as components in contact with, or embedded in, an outer leaf.

## INDEX

<b>A</b>		<b>F</b>		<b>S</b>	
Abutment details	4	Fire resistance	4, 5	Setting out	9
Admixtures and additives	3, 8, 20	Flashings	8	Sound insulation	5
Ancillary components	22	Frost attack	2, 18	Slates	8
<b>B</b>		<b>I</b>		Stone masonry	4, 7, 11
Background, rendering	6	Insulation, full fill	5, 16	Storage	15
Blockwork	5	Insulation, partial fill	5, 13	Structural support, lintels	4, 13
Bonding	1, 10	<b>J</b>		Sulfate	3
Bricks and blocks	7, 22	Joints	3	<b>T</b>	
<b>C</b>		<b>L</b>		Thermal insulation	5, 8, 14
Calcium silicate bricks	1, 7, 11	Lateral restraint	1	<b>W</b>	
Cavity trays	3, 11, 12, 13, 21	Lintels	4, 13	Wall ties	4, 8, 12
Cavity walls	5, 9	<b>M</b>		Workmanship	16
Cement	8	Mortar	3, 8, 9, 20		
Cladding	1, 5, 8	Movement joints	1, 8, 10		
Cold bridging	4	<b>O</b>			
Cold weather working	15	Openings	10		
Condensation	4	<b>P</b>			
Corbelling	2, 11	Parapet details	4		
<b>D</b>		Point loads	1		
Damp proof courses	3, 8, 11, 13, 21	Protection	1, 15		
Dry linings	5	<b>R</b>			
Durability	4, 22	Rain penetration	2, 5		
<b>E</b>		Reclaimed bricks	7		
Exposure	2, 18	Render	5, 8, 14		

# Chapter 6.2

## External timber framed walls

---



# 6.2

## External timber framed walls

### CONTENTS

	Clause	Page
<b>DESIGN</b>		
Design standards	D1	1
Statutory requirements	D2	1
Load bearing walls	D3	1
Moisture control and insulation	D4	1
Preservative treatment	D5	2
Exterior cladding	D6	2
Control of fire	D7	3
Provision of information	D8, D9	3
<b>MATERIALS</b>		
Materials standards	M1	3
Timber	M2	3
Timber preservation	M3	4
Sheathing	M4	4
Breather membranes	M5	4
Cavity barriers and fire-stops	M6	4
Holding down devices	M7	4
Nails and staples	M8	4
Vapour control layers	M9	4
Wall ties and fixings	M10	4
Wall Insulation	M11	4
<b>SITWORK</b>		
Sitework standards	S1	4
Construction	S2	4
Breather membranes	S3	5
Wall ties	S4	6
Insulation	S5	6
Vapour control layers	S6	6
Cladding	S7	6
Control of fire	S8	6
Services	S9	7
<b>APPENDIX 6.2-A</b>		
Certification procedure		7
<b>APPENDIX 6.2-B</b>		
Specimen certificate (England, Wales, Northern Ireland and Isle of Man),		7
<b>APPENDIX 6.2-C</b>		
Specimen certificate (Scotland)		8
<b>INDEX</b>		16

### SCOPE

This Chapter gives guidance on meeting the Technical Requirements and recommendations for external walls of timber framed dwellings, substantially timber framed dwellings and wall panels (including relevant certification procedures). This Chapter applies to timber framed walls up to seven storeys high.

DESIGN STANDARDS

6.2 - D1 Design shall meet the Technical Requirements

Dwellings with a timber frame superstructure require certification indicating that the design has been checked by an NHBC timber frame certifier. See Appendix 6.2-A.

Design that follows the guidance below will be acceptable for external walls of timber framed dwellings, substantially timber framed dwellings and wall panels. This Chapter applies to timber framed walls up to seven storeys high.

For guidance on the prevention of fire during construction see 'Fire Prevention on Construction Sites' jointly published by the Construction Federation and the Fire Protection Association ([www.thefpa.co.uk](http://www.thefpa.co.uk)) and guidance from the UKTFA under the 'Site Safety Strategy' that presents fire risk management publications such as the '16 Steps to Fire Safety' and the 'Design Guide to Separation Distances' ([www.uktfa.com](http://www.uktfa.com)).

STATUTORY REQUIREMENTS

6.2 - D2 Design shall comply with all relevant statutory requirements

Design should be in accordance with relevant Building Regulations and other statutory requirements.

LOADBEARING WALLS

6.2 - D3 Loadbearing timber framed walls shall be designed to support and transfer loads to foundations safely and without undue movement

Structural design of loadbearing timber framed walls should be in accordance with BS EN 1995-1-1. The design should take into account:

- wind loads
- roof loads
- floor loads.

Items to be taken into account include:

(a) structural elements

All structural timber should be:

- of a suitable grade in accordance with BS EN 338 and BS EN 14081-1
- dry graded and marked in accordance with BS 4978.

Sheathing and its associated fixings should be structurally adequate to resist racking due to wind and other forces.

Individual studs should be not less than 37mm wide, at maximum 600mm centres, unless other adequate support is provided for wall boards and fixings.

A lintel and cripple studs should be provided to any opening in load-bearing panels except when the opening does

not affect the stud spacing or where the supported loads are carried by a rim beam or perimeter joist.

Additional studs may be required at openings for fixing wall ties where masonry cladding is used.

Multiple studs should be included to support multiple joists and other point loads unless otherwise specified by the designer.

The design should avoid narrow, inaccessible gaps between studs which are difficult to insulate.

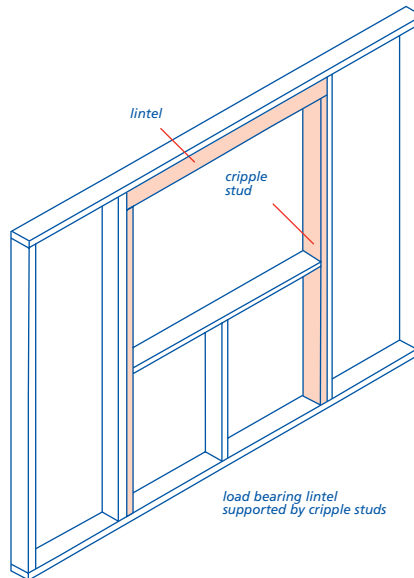

(b) anchoring the frame

Wall panels should be adequately fixed to the sole plate which in turn should be anchored to the substructure to resist all the lateral and vertical forces acting at these junctions. Typical details are shown in Clause S2.

Where frames are fixed to masonry or beam and block floors by shotfiring, the blocks should be concrete blocks to BS EN 771 with a minimum crushing strength of 7.3N/mm<sup>2</sup>. Blocks in beam and block floors should be grouted.

(c) joints between panels and other elements

Wall panels should be securely fixed together and fixed to floor and roof framing where appropriate. Appropriate measures should be taken to prevent buckling.

If head binders are not provided joists and roof trusses, including girder trusses and other similar loads, should bear directly over studs.

At joints between wall panels, sole plates and head binders should be provided to bind panels together. Joints in sole plates and head binder should not coincide with those between panels. Joints in head binders should occur over a stud.

MOISTURE CONTROL AND INSULATION

6.2 - D4 The design shall ensure that the structure is adequately protected from the effects of moisture

Items to be taken into account include:

(a) provision of dpcs and dpms

Dpcs should be installed below the sole plates of all ground floor walls, including internal partitions, to protect timber from rising damp and residual construction moisture.

Dpcs and trays should be fitted at openings where needed to prevent rain penetration.

In Scotland, Northern Ireland, the Isle of Man and other places where the exposure to driving rain is Severe or Very Severe, masonry should form a rebate at the reveals of openings to avoid a straight through joint where the frame abuts the masonry.

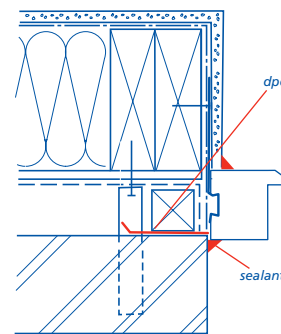

JAMB - SHELTERED

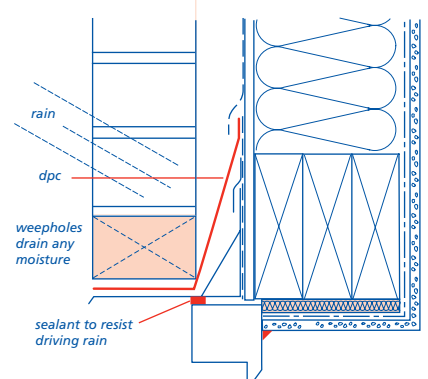

HEAD - SHELTERED

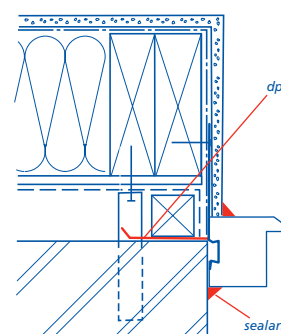

JAMB - SHELTERED

6.2

# 6.2

## External timber framed walls

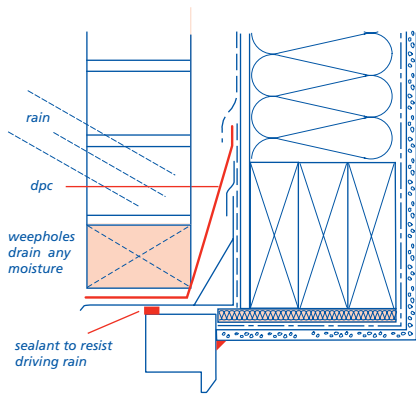

HEAD - SHELTERED

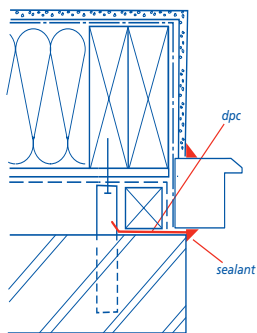

JAMB - EXPOSED

### (b) membranes

Breather membranes should be lapped so that each joint is protected and moisture drains outwards and downwards as shown in Clause S3.

In areas of Very Severe exposure to wind driven rain (as defined in Appendix 6.1-A) a high performance breather membrane should be used (unless the alternatives given in Clause D4(c) below are adopted).

### (c) cavities in external walls

A drained and vented cavity should be provided to reduce the risk of rain penetrating to the frame. The following minimum cavity widths, measured between the cladding and sheathing, should be provided:

Cladding	Minimum cavity width
Masonry	50mm nominal
Renderon backed lathing	25mm nominal
Verticaltile hanging without underlay	No vertical cavity required when a breather membrane is fitted to the sheathing
Othercladding*	15mm

\* See Chapter 6.9 'Curtain walling and cladding'.

In areas of *Very Severe* exposure to wind driven rain (as defined in Appendix 6.1-A) the wall construction should include a 50mm cavity between the sheathing and the cladding and:

- a high performance breather membrane, or

- a masonry cladding which is rendered or clad with an impervious material.

The cavity should be extended at least 150mm below dpc, to allow drainage of the cavity and should be kept clear. Open brick perpend should be provided where necessary to prevent water build up in the cavity. These openings can also provide cavity venting.

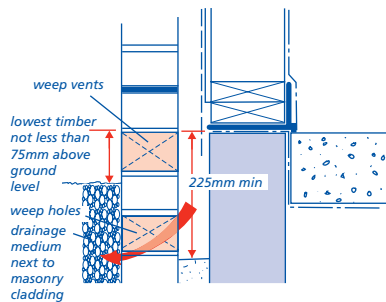
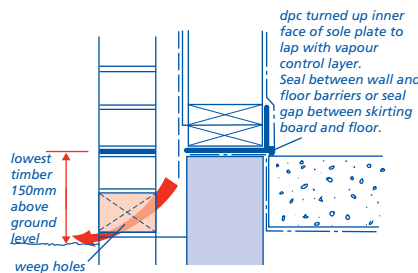

*Note: This detail is only acceptable in situations where the site is not subject to a high water table or where the cavity will not have standing water.*

The cavity should be vented to allow some limited, but not necessarily through, movement of air. Where wall areas are divided by horizontal cavity barriers and openings should be provided to each section (see Clause 6.2 - D7).

The openings should be:

- equivalent to open brick perpends every 1.2m
- located to prevent the ingress of rain, or
- below the lowest timber.

Proprietary perpend ventilators are available.

These openings can also provide drainage of the cavity.

### (d) insulation

The BRE Report 'Thermal insulation: avoiding risks' discusses aspects of insulation relevant to external timber framed walls. In England and Wales account should be taken of Accredited Details.

Insulation should normally be placed within the stud void. Partial fill cavity insulation, with a 50mm residual cavity, between it and any cladding may be needed but should be assessed in accordance with Technical Requirement R3 as an integral part of the wall system and installed in accordance with the assessment.

Insulated sheathing boards should be assessed in accordance with Technical Requirement R3 and installed in accordance with the assessment.

Wall insulation should be of a type which 'breathes' eg, mineral wool (rock or glass). Other insulation materials should be assessed in accordance with Technical Requirement R3 for use in timber frame wall panels and installed in accordance with the assessment.

Water and heating services within walls should be on the warm side of the insulation.

### (e) vapour control layers for walls

A vapour control layer should be fixed on the warm side of the wall insulation.

The vapour control layer should cover the external wall including bottom rails, head rails, studs, lintels and window reveals.

Vapour control layers should be of 500 gauge (120 micron) polyethylene or vapour control plasterboard.

All joints in sheet vapour control layers should have at least 100mm laps and be located on studs or noggings and be adequately fixed to the frame.

## PRESERVATIVE TREATMENT

**6.2 - D5 Timber and timber products shall either be naturally durable or where necessary be treated with preservative to give adequate resistance against decay and insect attack**

Items to be taken into account include:

### (a) timber framing

Timber framing should be treated in accordance with the guidance in Chapter 2.3 'Timber preservation (natural solid timber)', to which reference should be made.

I-studs manufactured from timber of durability class 'moderately durable' or lower should be preservative treated in accordance with Chapter 2.3 'Timber preservation (natural solid timber)'.

### (b) timber cladding

Timber cladding should be treated in accordance with the guidance in Chapter 2.3 'Timber preservation (natural solid timber)'.

## EXTERIOR CLADDING

**6.2 - D6 Exterior cladding shall be compatible with the timber frame**

Items to be taken into account include:

### (a) cavity

A drained and vented cavity between exterior cladding and the sheathing should be specified as detailed in Clause D4. This cavity should not contain electricity cables other than meter tails.



**(b) wall ties**

Wall ties should be:

- of a type which complies with BS EN 845 and fully permits differential movement between the timber frame and the cladding - see Clause D6(c) below
- fixed to studs, not sheathing
- spaced at a maximum of 600mm horizontally and 450mm vertically
- spaced at jambs of openings and at movement joints in masonry a maximum of 300mm vertically within 225mm of the masonry reveal or movement joint. In this case additional studs may be needed
- spaced within 225mm of the top of a masonry wall
- inclined away from the sheathing so that the slope is maintained following differential movement.

**(c) movement between the timber frame wall and other elements.****DIFFERENTIAL MOVEMENT**

During the first two years after erection, the timber frame will reduce in overall height as it dries out. The anticipated amount of shrinkage of the timber frame is given in Appendix 6.2-C.

Movement between the timber frame and other parts of the construction will occur at:

- door and window openings
- eaves and verges
- balconies (including Juliet balconies)
- openings for drive-throughs
- staircases and lift shaft enclosures (where they are not timber framed)
- service entries
- the interface of the timber frame with any other construction.

Appendix 6.2-C provides guidance on the anticipated amount of shrinkage of the timber frame and where it will occur between other parts of the structure. The extent of the differential movement increases with the number of storeys. Movement gaps should be filled with suitable materials to take up the expected movement. The manufacturer of the material should be consulted on the suitability for the extent of the movement expected.

Where the movement gap is expected to be more than 35mm it should be protected by a cover strip.

All claddings that are fixed direct to the timber frame, should have a horizontal movement joint at each floor level. See Appendix 6.2-C

Masonry claddings should not be supported by the timber frame.

**(d) prefabricated chimneys**

Prefabricated chimneys should either be supported by:

- the masonry cladding, or
- the timber frame, including any roof construction supported by the timber frame.

**(e) services**

Differential movement should be allowed for services both within the timber frame envelope or where they pass through it. Additional guidance is given in Appendix 6.2-C or in the case of gas services publications from the Institution of Gas Engineers and Managers ([www.igem.org.uk](http://www.igem.org.uk)).

**CONTROL OF FIRE****6.2 - D7 Walls and panels shall resist the spread of fire**

For guidance on the prevention of fire during construction see 'Fire Prevention on Construction Sites' jointly published by the Construction Federation and the Fire Protection Association ([www.thefpa.co.uk](http://www.thefpa.co.uk)) and guidance from the UKTFA under the 'Site Safety Strategy' that presents fire risk management publications such as the '16 Steps to Fire Safety' and the 'Design Guide to Separation Distances' ([www.uktfa.com](http://www.uktfa.com)).

All elements should have adequate fire resistance.

Service mains should not pass through separating wall cavities.

In Scotland services are not permitted within a timber framed separating wall.

Service outlets should not impair the fire resistance of floors and walls.

Items to be taken into account include:

**(a) cavity barriers**

The design should detail the position and materials for cavity barriers in accordance with relevant Building Regulations.

Horizontal cavity barriers (except under eaves) should be protected with a dpc tray. The tray should have a minimum upstand of 100mm. Alternatively polyethylene encased cavity barriers providing a minimum upstand of 100mm should be used.

Dpcs should be used to cover horizontal and vertical cavity barriers and to shed moisture away from the sheathing. Typical details are shown in Clause S8.

Vertical timber cavity barriers should be protected from penetrating moisture by a dpc.

**(b) fire-stops**

The design should detail the position and type of fire-stops in accordance with relevant Building Regulations.

A typical fire-stop detail is shown in Clause S8.

**PROVISION OF INFORMATION****6.2 - D8 All relevant information shall be distributed to appropriate personnel**

Ensure that design and specification information is issued to site supervisors

and relevant specialist subcontractors and/or suppliers.

Where proprietary products are to be used, manufacturers usually have specific requirements for fixing and/or assembly of their products. This information should also be made available for reference on site so that work can be carried out satisfactorily in accordance with the design and specification.

The fixing schedule should allow for every structural connection made on site including fixing details for framing, wall ties, breather membrane, sheathing and vapour control layers, and should show as appropriate:

- number and spacing of nails and staples
- size and type of nail including material and corrosion protection
- method of nailing (eg skew, end, etc.).

Where the wall design relies on plasterboard to take racking forces those walls should be clearly defined and the type and centres of the fixings stated.

Copies of the fixing schedule should be given to the person doing the job.

**6.2 - D9 Design of the superstructure shall be checked by an NHBC timber frame certifier**

The superstructure design should be placed with an NHBC approved timber frame certifier so that a certificate can be issued in accordance with Appendix 6.2-A.

**MATERIALS STANDARDS****6.2 - M1 All materials shall:**

- (a) meet the Technical Requirements**
- (b) take account of the design**

Materials that comply with the design and the guidance below will be acceptable for external timber framed walls including wall panels and dwellings which are substantially timber framed.

Materials should comply with all relevant standards, including those listed below. Where no standard exists, Technical Requirement R3 applies (see Chapter 1.1 'Introduction to the Standards and Technical Requirements').

References to British Standards and Codes of Practice include those made under the Construction Products Directive (89/106/EEC) and, in particular, appropriate European Technical Specifications approved by a European Committee for Standardisation (CEN).

**TIMBER****6.2 - M2 All timber shall be of a grade suitable for the design**

All structural timber should be:

- of a suitable grade in accordance with BS EN 338 and BS EN 14081-1

- dry graded and marked in accordance with BS 4978.

I-studs should be assessed in accordance with Technical Requirement R3.

## TIMBER PRESERVATION

**6.2 - M3 Timber shall be either naturally durable or preservative treated to provide adequate protection against rot and insect attack**

Timber preservation should be in accordance with Chapter 2.3 'Timber preservation (natural solid timber)'.

I-studs manufactured from timber of durability class 'moderately durable' or lower should be preservative treated in accordance with Chapter 2.3 'Timber preservation (natural solid timber)'.

## SHEATHING

**6.2 - M4 Sheathing shall be durable and capable of providing structural resistance to racking**

The following materials are acceptable:

- plywood in accordance with BS EN 636 and BS EN 13986 table 7
- oriented strand board in accordance with BS EN 300 type OSB/3 or 4
- moisture-resistant chipboard in accordance with BS EN 312 type P5 or P7.
- medium board in accordance with BS EN 622-3 type MBH.HLS1 or MBH.HLS2.
- impregnated soft board in accordance with BS EN 622-4 type SB.HLS.

Proprietary sheathing materials should be assessed in accordance with Technical Requirement R3 and used in accordance with the assessment.

## BREATHER MEMBRANES

**6.2 - M5 Breather membranes shall be capable of allowing water vapour from within the frame to pass out into the cavity and protect the sheathing and frame from external moisture**

Breather membranes should be:

- vapour resistant to less than 0.6MN/g when calculated from the results of tests carried out in accordance with BS 3177 at 25 °C and relative humidity of 75%
- capable of resisting water penetration
- self extinguishing
- durable
- adequately strong when wet to resist site damage
- Type 1 to BS 4016 in areas of Very Severe exposure (unless the alternatives given in Design Clause D4(c) are adopted).

## CAVITY BARRIERS AND FIRE-STOPS

**6.2 - M6 Materials used for cavity barriers and fire-stops shall be capable**

**of providing adequate resistance to fire and smoke**

Materials specified in statutory requirements are acceptable.

Other materials may be used if satisfactorily assessed in accordance with Technical Requirement R3.

## HOLDING DOWN DEVICES

**6.2 - M7 Holding down devices shall be of durable material**

Holding down devices should be manufactured from:

- austenitic stainless steel to BS EN 10088-1, minimum grade 1.4301
- galvanised mild steel with zinc coating to BS EN ISO 1461, minimum coating 940 g/m<sup>2</sup> on each side.

Sole plate anchors within the internal envelope should be galvanised mild steel, minimum coating Z275.

All holding down devices should be as detailed in the design.

## NAILS AND STAPLES

**6.2 - M8 Nails and staples shall be durable and of the correct type to provide adequate mechanical fixing**

Staples for fixing breather membranes should be austenitic stainless steel or other material of similar strength and corrosion resistance.

Nails for fixing sheathing or timber should be galvanised, sheradized or austenitic stainless steel.

## VAPOUR CONTROL LAYERS

**6.2 - M9 Vapour control layers shall restrict the passage of water from within the dwelling to the timber frame**

Vapour control layers should be 500 gauge (120 micron) polyethylene sheet or vapour control plasterboard.

Vapour control products manufactured from recycled materials should be assessed in accordance with Technical Requirement R3.

## WALL TIES AND FIXINGS

**6.2 - M10 Wall ties and fixings shall be capable of properly connecting the cladding to the timber frame in accordance with the design**

Wall ties and their fixings should be of austenitic stainless steel, comply with BS EN 845 and be capable of accommodating the anticipated differential movement given in Appendix 6.2-C.

## INSULATION

**6.2 - M11 Insulation materials shall provide the degree of insulation to comply with the design and statutory requirements**

Wall insulation should be of a type that 'breathes', eg mineral wool (rock or glass). Other insulation used in walls should be assessed in accordance with Technical Requirement R3 for use in timber frame wall panels.

## SITWORK STANDARDS

**6.2 - S1 All sitework shall:**

- (a) meet the Technical Requirements**
- (b) take account of the design**
- (c) follow established good practice and workmanship**

All relevant information in a form suitable for the use of site operatives should be available on site before construction starts including:

- full set of drawings
- materials specification
- fixing schedules
- nailing details
- manufacturers' recommendations relating to proprietary items.

## CONSTRUCTION

**6.2 - S2 Construction shall ensure that the building is structurally adequate**

**(a) setting out**

The substructure should be correctly set out to receive the timber frame which will be manufactured to close tolerances. The timber frame should be checked to ensure that it is erected accurately both on plan and vertically. The load from the frame should be supported as intended in the design. Where packing under sole plates is necessary it should be in accordance with Appendix 6.2-B.

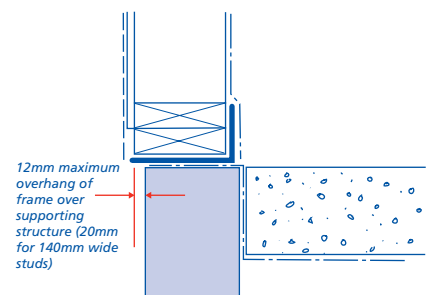

Ledges can form moisture traps. Where these occur protection should be provided.

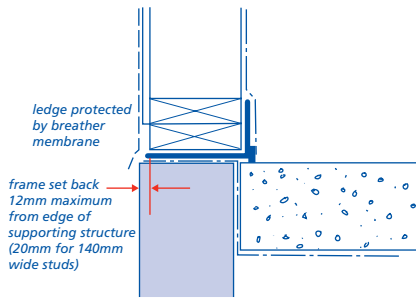

**(b) anchoring the frame**

The frame should be anchored to resist both lateral movement and uplift. Care should be taken to avoid splitting timber plates or damaging the substructure.

When shotfiring, care should be taken not to spall edges of masonry or slabs. When shotfiring into masonry, solid concrete blocks with a minimum crushing strength of 7.3N/mm<sup>2</sup> should be used, positioned to receive fixings.

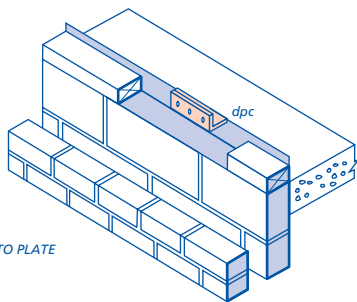

FIXING TO PLATE

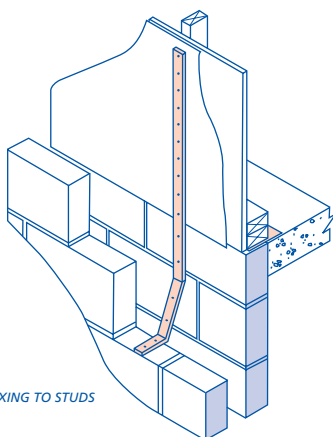

FIXING TO STUDS

**(c) fixing panels**

All fixings, including nailed joints and sheathing, should be as scheduled in the design.

Wall panels should be securely fixed together and to floor and roof framing.

Sole plates and head binders should be provided to bind the panels together. Joints in sole plates and head binders should not coincide with those between panels. Joints in head binders should occur over a stud.

If head binders are not provided, joists and roof trusses, including girder trusses and other similar loads, should bear directly over studs. Individual studs should be not less than 37mm wide, at maximum 600mm centres, unless other adequate support is provided for wall boards and fixings.

A lintel and cripple studs should be provided to any opening in loadbearing panels except when the opening does not affect the stud spacing or where the supported loads are carried by a rim beam or perimeter joist.

Unless otherwise clearly specified by the designer, multiple studs should be included to support multiple joists.

**(d) supporting claddings**

Wall ties should be in accordance with the design and fixed to studs.

Battens supporting lightweight cladding should be fixed to studs.

**(e) fixing plasterboard**

Plasterboard should be fixed in accordance with Chapter 8.2 'Wall and ceiling finishes' (Sitework) unless the design specifies closer fixing centres

Particular care should be taken at the junction between walls and roofs. Reference should be made to Chapter 8.2 'Wall and ceiling finishes' (Sitework).

**(f) movement between timber frame wall and other elements**

The timber frame will reduce in overall height as it dries out. The anticipated amount of shrinkage of the timber frame and where it will occur between other parts of the structure is given in Appendix 6.2-C.

Movement will occur at:

- door and window openings
- eaves and verges
- balconies (including Juliet balconies)
- openings for drive-throughs
- staircases and lift enclosures (where they are not timber framed)
- service entries
- the interface of the timber frame with any other construction.

The extent of the differential movement increases with the number of storeys. Movement gaps should be filled with suitable materials to take up the expected movement. The manufacturer of the material should be consulted on the suitability for the extent of the movement expected.

Where the movement gap is expected to be more than 35mm it should be protected by a cover strip.

All claddings that are fixed directly to the timber frame, should have a horizontal movement joint at each floor level. See Appendix 6.2-C.

Masonry claddings should not be supported by the timber frame.

**(g) prefabricated chimneys**

Prefabricated chimneys should either be supported by:

- the masonry cladding, or
- the timber frame, including any roof construction supported by the timber frame.

**(h) cavities**

A cavity should be provided to reduce the risk of rain penetrating to the frame. The following minimum cavity widths, measured between the cladding and sheathing, should be provided:

Cladding	Minimum cavity width
Masonry	50mm nominal
Render on backed lathing	25mm nominal
Vertical tile hanging without underlay	No vertical cavity required when a breather membrane is fitted to the sheathing
Other cladding*	15mm

\*See Chapter 6.9 'Curtain walling and cladding'.

A clear cavity for at least 150mm below dpc should be maintained. Weep holes (eg open perpend) should be provided where necessary to prevent water build up in the cavity.

**BREATHER MEMBRANES**

**6.2 - S3 Breather membranes shall where required protect the sheathing from dampness**

Special attention should be given to the following details:

- laps, which should be at least 100mm on horizontal joints and 150mm on vertical joints as shown in the following diagram
- direction of laps - upper layers should be fixed over lower layers to ensure rain runs away from the sheathing. Vertical joints should be staggered wherever possible
- fixing should be at regular intervals to prevent damage by wind and should be not more than 600mm centres horizontally, 300mm centres vertically and 150mm centres around openings
- marking the stud positions for wall tie fixing
- shedding water away from the lowest timber
- use of self extinguishing grade membrane
- use of high performance breather membrane in areas of Very Severe exposure to wind driven rain (as defined in Appendix 6.1-A) (unless the alternatives given in Design Clause D4(c) are adopted)
- use of fixings described in Chapter 6.2 (Materials).

# 6.2

## External timber framed walls

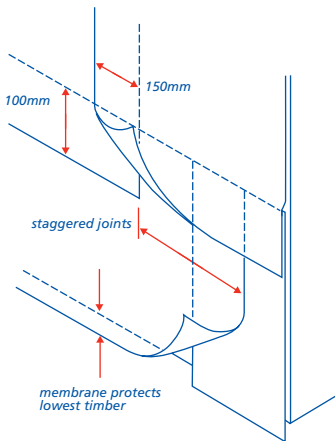

Damaged membranes should be repaired or replaced before proceeding with the cladding.

When bitumen impregnated fibre building board is used and a breather membrane is not specified the joints of the boards should be closely butted and horizontal joints sealed to prevent water ingress.

When a breather membrane is not required the bottom frame members should be protected from water in the cavity.

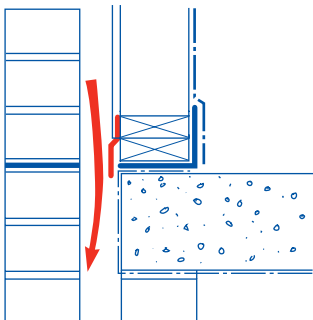

### WALL TIES

#### 6.2 - S4 Wall ties shall be correctly installed

- of the type specified in the design
- fixed to the studs not the sheathing
- be sufficiently flexible or of a type that fully permits differential movement
- be kept clean and free from mortar droppings
- spaced at a maximum of 600mm horizontally and 450mm vertically
- spaced at jambs of openings and at movement joints in masonry a maximum of 300mm vertically within 225mm of the masonry reveal or movement joint
- spaced within 225mm of the top of a masonry wall
- inclined away from the sheathing so that the slope is maintained following differential movement.

### INSULATION

#### 6.2 - S5 Insulation shall be correctly installed

Insulation should cover the whole wall area between studs. No gaps should be left:

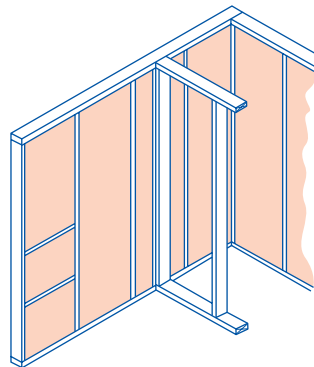

- against studs or rails
- at corners
- against noggings
- at junctions with partitions
- behind service panels.

### VAPOUR CONTROL LAYERS

#### 6.2 - S6 Vapour control layers shall be correctly installed

Before fixing a vapour control layer the framing timbers should have a moisture content of 20% or less.

The vapour control layer should be fixed on the warm side of the insulation and frame.

The vapour control layer should be the material specified in the design. 500 gauge (120 microns) polyethylene sheet or vapour control plasterboard should be used. Where vapour control plasterboard is used joints between sheets should be positioned on studs or noggings and the joints should be filled, taped and finished.

Where polyethylene is used all joints in the vapour control layer should have at least 100mm laps and be located on studs or noggings.

Vapour control layers should be fixed at 250mm centres to the top and bottom of the frame, at laps and around openings.

When cutting vapour control plasterboard care should be taken not to displace the vapour control material.

Any holes made in a vapour control layer should be made good.

The vapour control layer should cover the external framed wall area including rails, studs, reveals, lintels and sills.

The vapour control layer should lap with the dpc.

### CLADDING

#### 6.2 - S7 Cladding and its fixings shall not obstruct the cavity and shall allow for differential movement

Horizontal battens, which obstruct the drained and vented cavity, should not be used to support cladding except tile hanging.

The cavity should be vented to allow some limited, but not necessarily through, movement of air. Where wall areas are divided by horizontal cavity barriers and openings should be provided to each section (see Design clause 6.2 - D7).

The ventilation openings should be:

- equivalent to open brick perpend every 1.2m.
- placed to prevent the ingress of rain or should be below the lowest timber.

Proprietary perpend ventilators are available.

These openings can also provide drainage.

The cavity should be kept clean, free of obstructions and be capable of draining freely.

All proprietary cladding should be fixed in accordance with the manufacturer's recommendations.

Masonry cladding should be constructed in accordance with Chapter 6.1 'External masonry walls'.

### CONTROL OF FIRE

#### 6.2 - S8 Fire spread shall be controlled as detailed in the design

For guidance on the prevention of fire during construction see 'Fire Prevention on Construction Sites' jointly published by the Construction Federation and the Fire Protection Association ([www.thefpa.co.uk](http://www.thefpa.co.uk)) and guidance from the UKTFA under the 'Site Safety Strategy' that presents fire risk management publications such as the '16 Steps to Fire Safety' and the 'Design Guide to Separation Distances' ([www.uktfa.com/](http://www.uktfa.com/)).

### CAVITY BARRIERS

Cavity barriers should be installed in positions detailed by the design and relevant Building Regulations.

Cavity barriers should be formed of materials specified in the design. If no specification is available the advice of the designer should be obtained.

Horizontal cavity barriers (except under eaves) should be protected with a dpc tray. The tray should have a minimum upstand of 100mm. Alternatively polyethylene encased cavity barriers providing a minimum upstand of 100mm should be used.

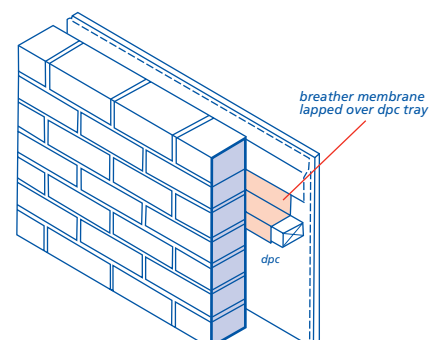



Vertical timber cavity barriers should be protected from moisture by a dpc.

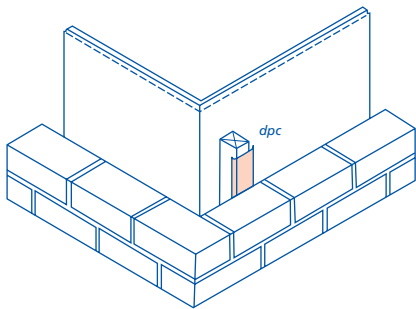

**FIRE-STOPPING**

Fire-stops should be installed in positions detailed in the design and relevant Building Regulations.

Only those materials specified in the design should be used for fire-stopping.

If details of fire-stop design, location and materials are not available they should be verified with the designer before construction commences.

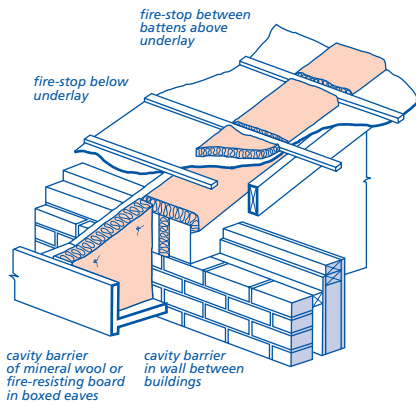

**SERVICES**

**6.2 - S9 Services shall not reduce the fire resistance or stability of the dwelling**

Service outlets should not impair the fire resistance of floors and walls.

Only those services shown in the design should be installed in separating walls.

Notching or drilling of structural timber members should be carried out as detailed in the design. If these details are not available the designer should be consulted before such operations are started.

See Appendix 6.2 - C.

**APPENDIX 6.2-A**

**Certification**

**Certifiers**

The timber frame certifier is required to complete and sign a certificate

confirming that he has assessed the structural adequacy of the timber frame superstructure for a specific project.

The completed and signed certificate must be given to the registered builder.

Certifiers must be suitably qualified civil or structural engineers with at least three years' experience in timber frame construction and Chapter 6.2 'External timber framed walls'. The certifier must not be the designer of the timber frame.

Where the design is four storeys or more and the floor joists are solid timber the design is to be submitted to NHBC.

Applications to become a timber frame certifier should be made to NHBC Standards and Technical.

**Registered builders**

Registered builders should ensure that the completed timber frame certificate is available on site for inspection by NHBC.

**APPENDIX 6.2-B**

**Packing under sole plates**

The finished surface of the substructure supporting the timber frame should be reasonably level. However, where packing is required to ensure the timber frame or sole plate is level, the following three alternative options are acceptable.

The options given are for packing up to 20mm. Packing exceeding 20mm should be agreed between the timber frame manufacturer's engineer and NHBC.

**1 Permanent structural packing under sole plate**

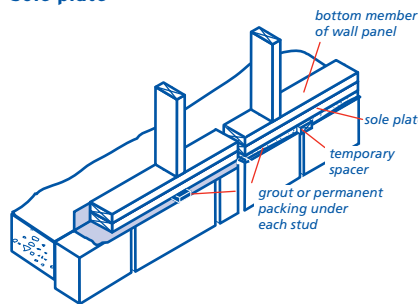

The sole plate is levelled on temporary spacers. Once the first lift construction - wall panel and first floor floor structure (or roof structure in a single storey building) - has been erected, permanent packing is placed under the sole plate.

This permanent packing can be:

- free flowing non-shrinkable grout for the full length and width of the sole plate, or
- individual packers placed under each load point (e.g. stud or post).

**2 Bedding of sole plate**

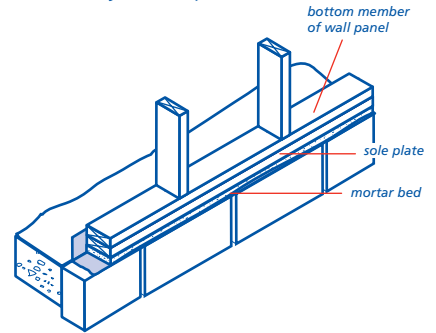

The sole plate is laid and levelled on a continuous bed of mortar, prior to the erection of the wall panels. The bedding should extend the full width of the sole plate. Care is needed to ensure that the bedding is not disturbed during the fixing of the sole plate.

**3 Double sole plate 'sandwich'**

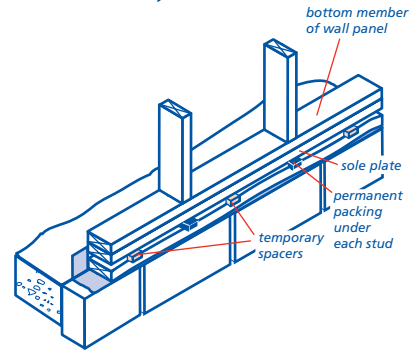

The lower sole plate is fixed to follow the contours of the supporting structure. The upper sole plate is fixed on top and levelled with temporary spacers inserted between the sole plates. Once the first lift construction has been erected permanent packing is inserted under each load point (e.g. stud or post).

Because this method introduces an additional sole plate the extra shrinkage should be taken into account. See Appendix 6.2-C.

**Notes**

- 1 Permanent packing should be designed and approved by the timber frame designer to suit the horizontal and vertical loads on the sole plate and should be at least the same plan area as the load points (e.g. studs or posts). Hollow plastic packing with reduced bearing surfaces is not acceptable.
- 2 Temporary spacers can remain in place providing they are durable and non-degradable.
- 3 Grout and mortar are both unsuitable for gaps less than 5mm and in such cases permanent packing should be used.

### APPENDIX 6.2-C

#### DIFFERENTIAL MOVEMENT

##### INTRODUCTION

During the first two years after erection the timber frame will reduce in overall height as it dries out. Movement will occur between the timber frame and other parts of the structure.

This Appendix contains:

- guidance on differential movement of the timber frame, and
- common details for timber frame construction where differential movement will take place.

The sketches show examples of typical interfaces and illustrate general design principles.

In the absence of project specific calculations the gaps shown in the following table, are required:

#### Table of differential movement

Gap location	Opening and Closing gaps(mm)	
	Solid timber (mm)	Engineered I-joist (mm)
Floor joists		
Eaves/verge	Add 5mm to gap dimension at level below	
Sixth storey	Specialist calculations to be submitted to NHBC	61
Fifth storey		53
Fourth storey		45
Third storey	45	35
Second storey	35	25
First storey	20	15
Ground storey*	5	5

\*Ground storey or lowest level of timber frame.

##### Notes

The gap sizes are based on the following :

- timber joist and rim beam/header joist maximum depth 240mm
- timber frame floor cross section is as shown below with maximum 45mm deep timber plates/binders
- single head binder at the eaves. Maximum double sole plates
- calculations, where required, to be based on BS EN 1995-1-1
- timber components are not saturated and normal moisture contents at the time of construction (e.g. less than 20%) and tight jointed construction
- movement gaps in excess of 35mm should be protected by cover strips
- the table allows for a 2mm thickness of compressible material in closing gaps. Check the manufacturer's product details
- outer leaf brickwork with expansion rates no greater than 2.5mm per storey
- brickwork up to 5 storeys with lightweight cladding above 5 storeys
- lightweight cladding - floor level joints to be 15mm for solid timber and 10mm for engineered I-joists.
- the ground floor is concrete. For ground floors of timber joists add 15mm for solid timber and 10mm for engineered I-joists

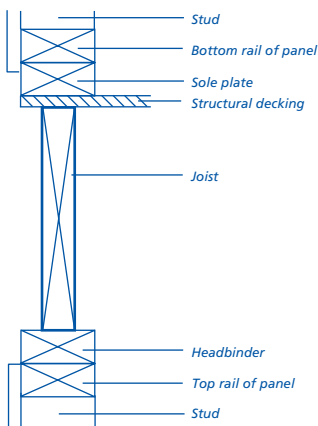

Timber frame construction on which the table of differential movement above is based.

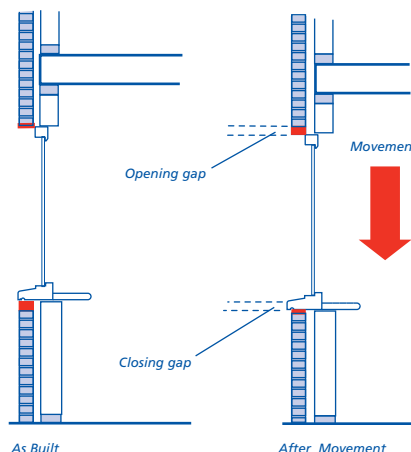

Location of opening and closing gaps at windows.

## COMMON DETAILS

The following sketches show examples of typical construction details and illustrate general principles relating to differential movement.

Further information is available from the UKTFA document 'Guidance on detailing to accommodate differential movement in timber frame buildings'. This UKTFA publication includes guidance on:

- the interface between a lift shaft and the timber frame
- the interface between lightweight cladding to the timber frame and balconies
- the support of roofs above lift shafts etc. constructed from masonry or concrete
- staircases within the timber frame
- services within the timber frame
- additional chimney details.

In the following sketches:-

- ↓ = downward movement of the timber frame
- ↑ = upward brick expansion (taken as 2.5mm per storey of clay masonry).

The design should ensure that the material used in movement joints will safely accommodate the amount of expansion or compression expected and, where required, provide a weather resistant and durable joint. See Clauses 6.2-D6 and S2.

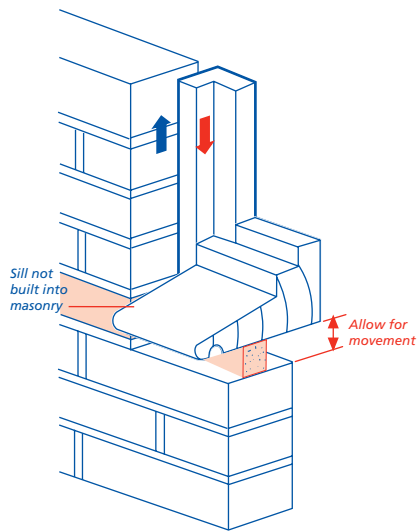

Normal reveal

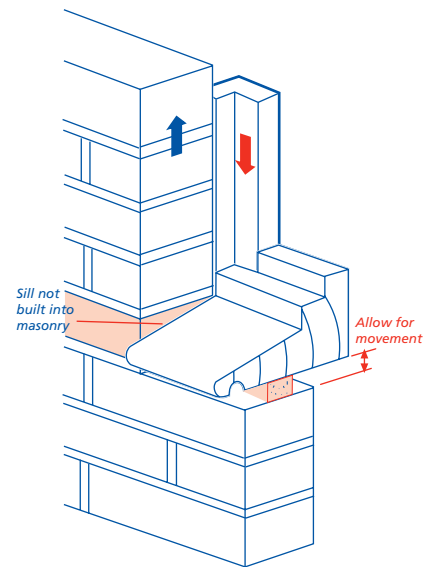

Check reveal

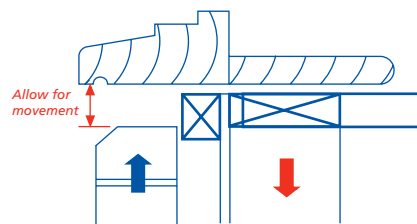

As built

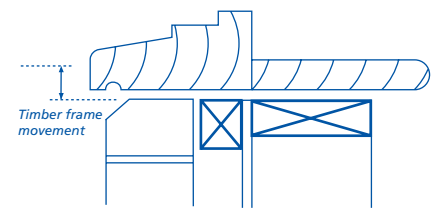

After movement



# 6.2

## External timber framed walls

### WINDOW HEADS WITH MASONRY CLADDING

(movement gaps in excess of 35mm should be protected by cover strips) (cavity trays omitted for clarity)

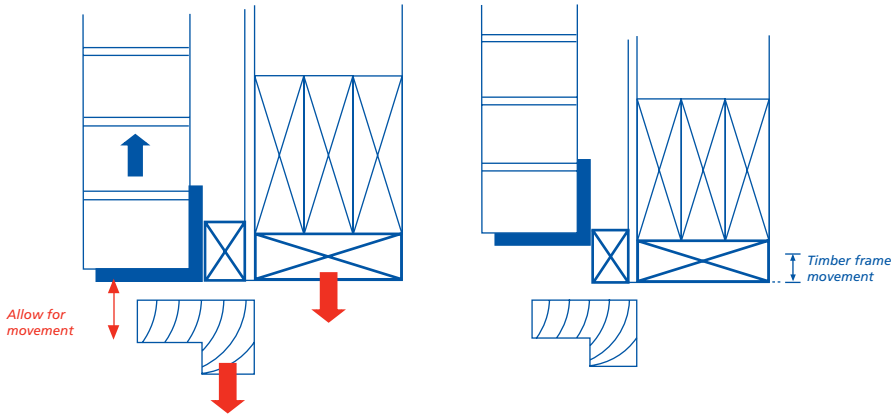

As Built

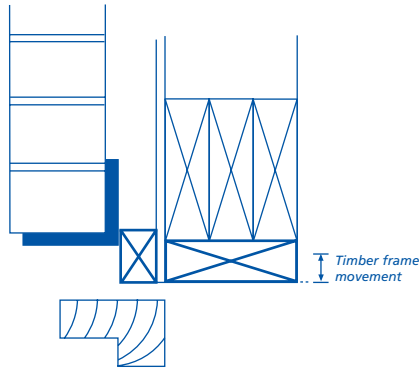

After movement

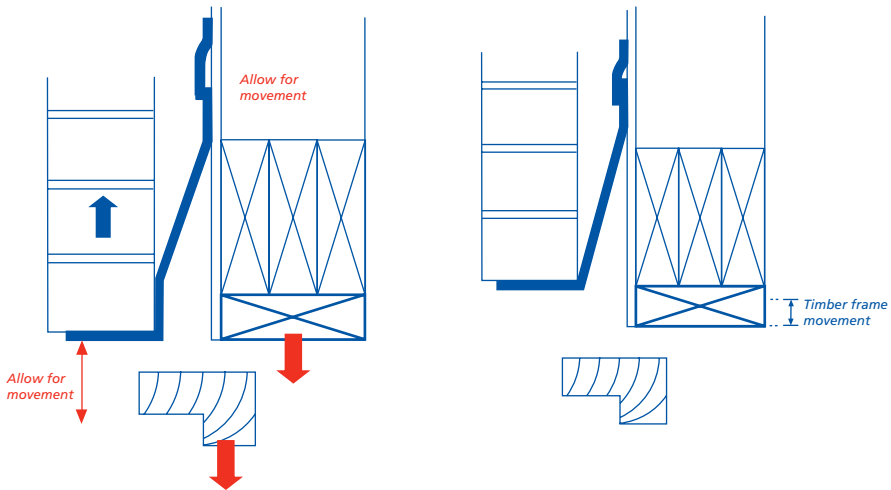

As Built

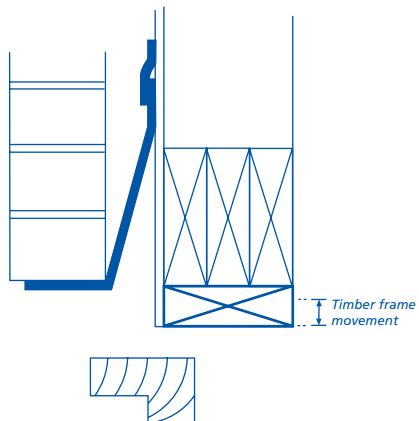

After movement

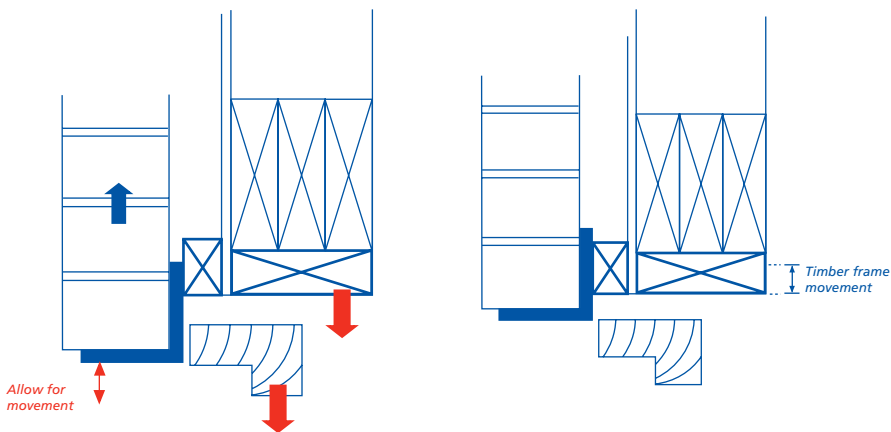

As Built

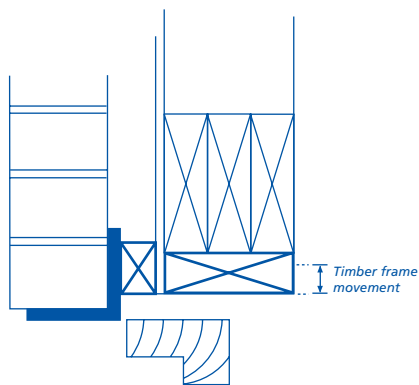

After movement

**WINDOW HEAD AND SILL WITH LIGHTWEIGHT CLADDING**

(movement gaps in excess of 35mm should be protected by cover strips)

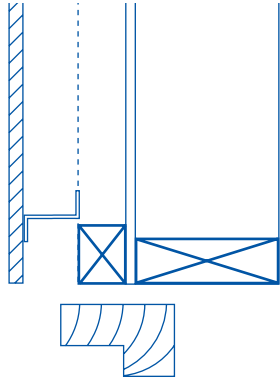

No differential movement

Head with lightweight cladding

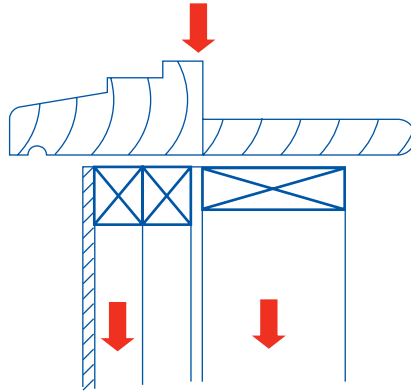

No differential movement

Sill with lightweight cladding

**ROOF TO CHIMNEY ABUTMENT**

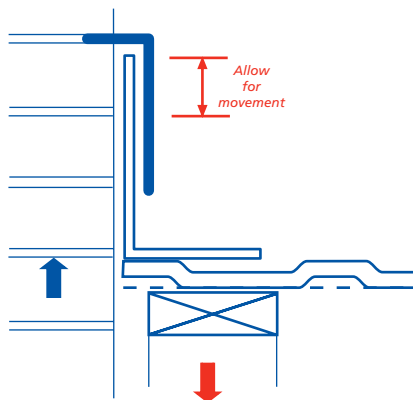

As Built

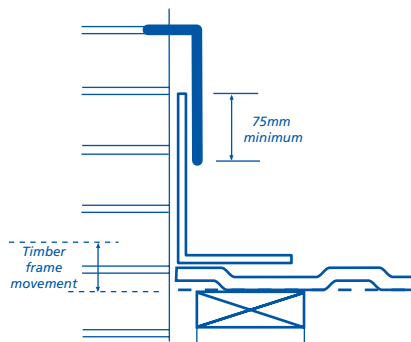

After movement

**TIMBER FRAME INTERFACE WITH CONCRETE OR MASONRY STAIRS AND COMMON AREAS**

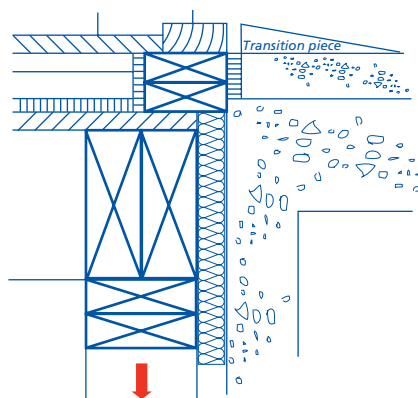

As built

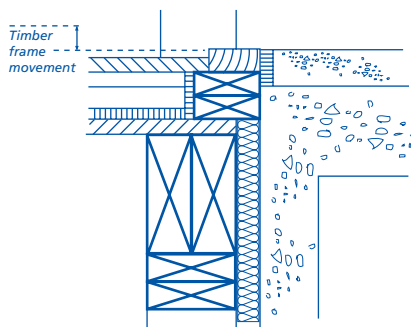

After movement (transition piece removed)

6.2

# 6.2

## External timber framed walls

### EAVES

(movement gaps in excess of 35mm should be protected by cover strips)

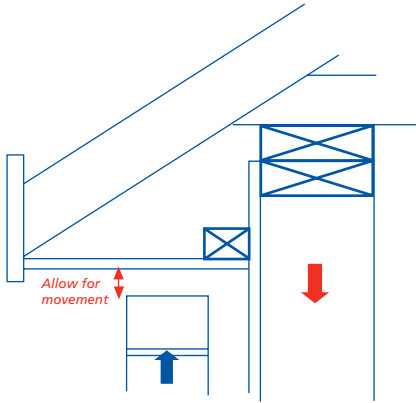

As Built

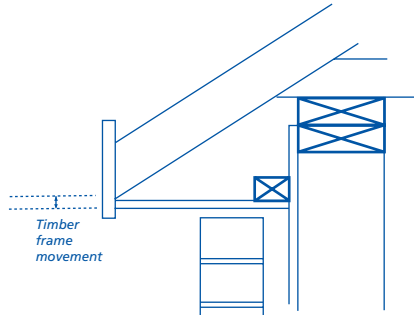

After movement

### VERGE

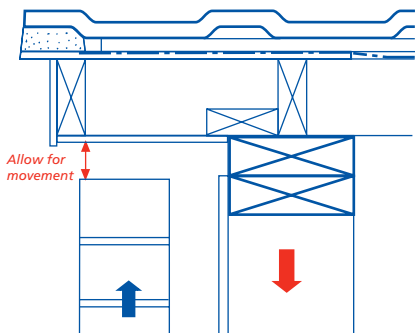

As Built

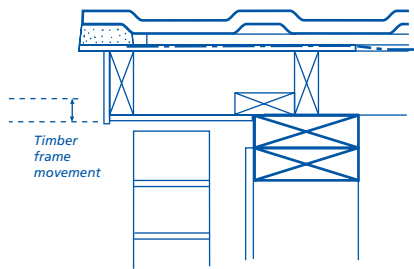

After movement

### SERVICES

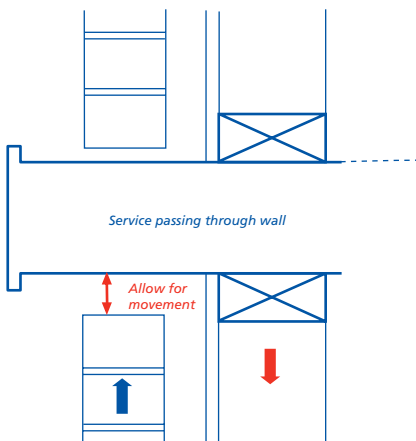

As built

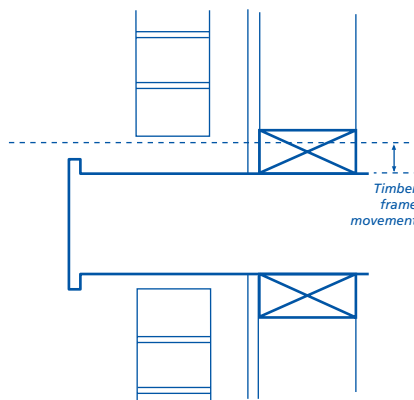

After movement

6.2

## DRIVE THROUGH

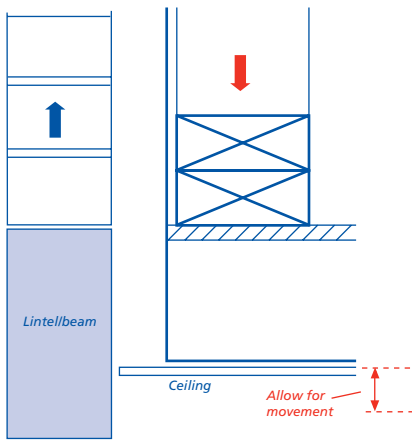
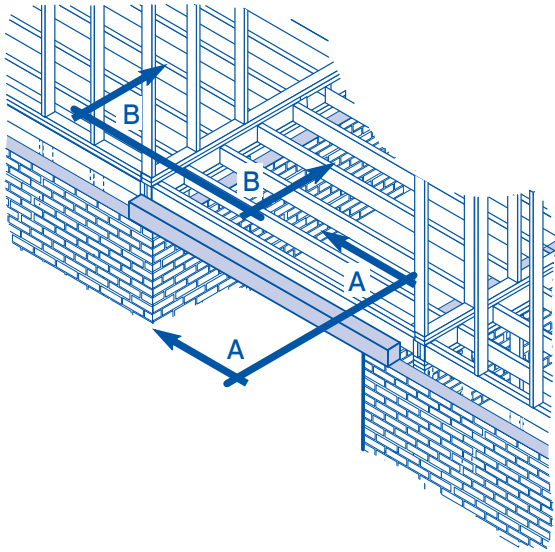

As built

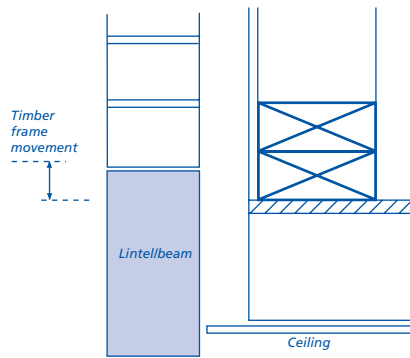

After movement

### Section A - A

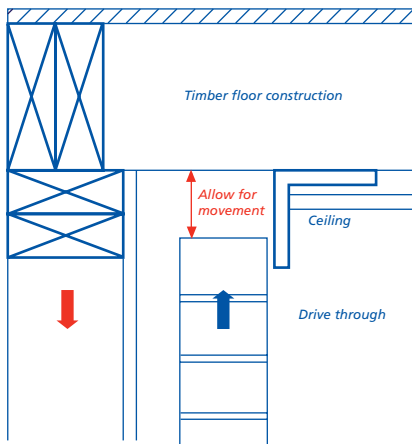

As Built

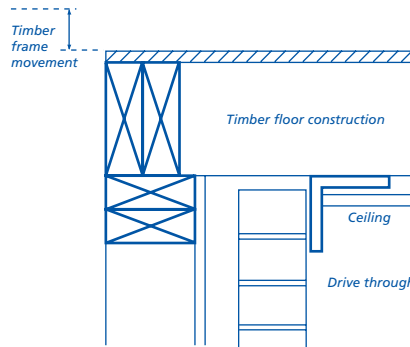

After movement

### Section B - B

# 6.2

## External timber framed walls

### BALCONY ABUTMENTS

(movement gaps in excess of 35mm should be protected by cover strips)

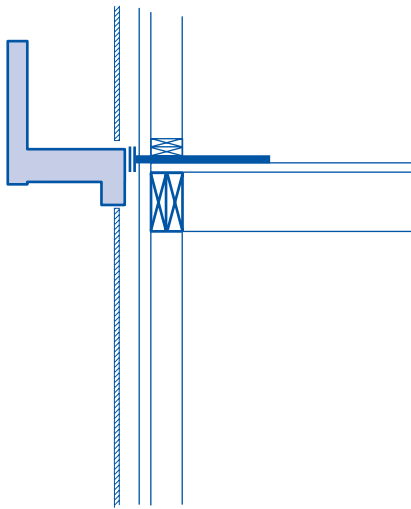

Balcony - lightweight cladding

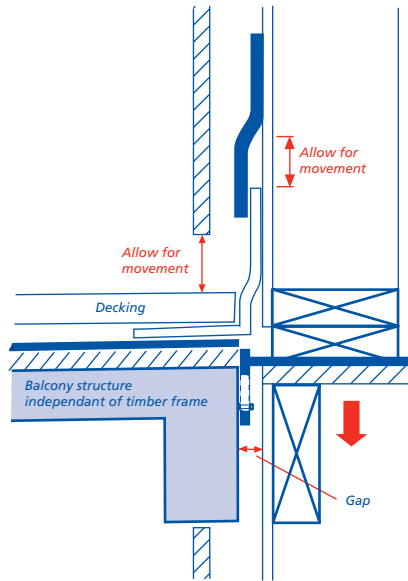

As built

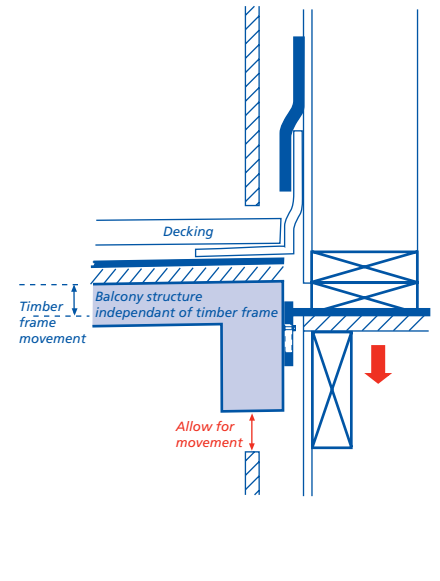

After movement

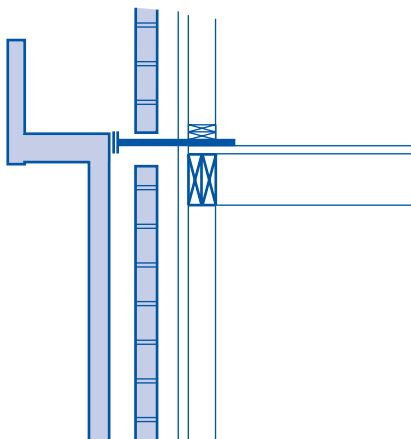

Balcony - masonry cladding

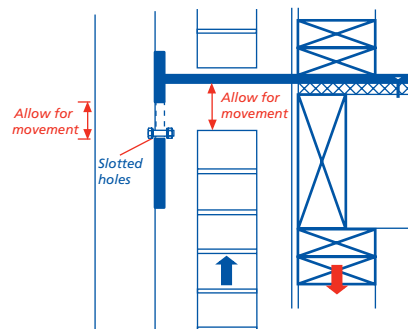

As built

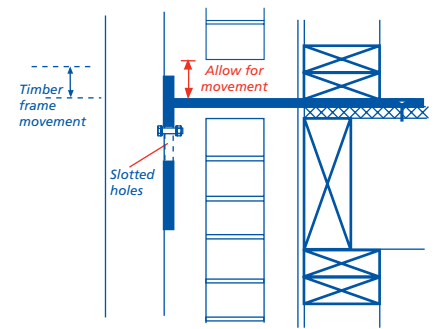

After movement

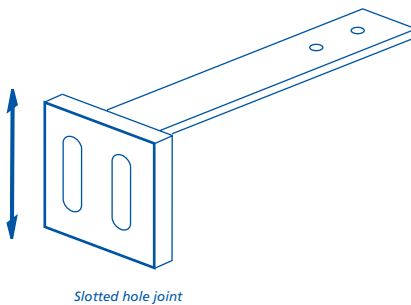

Slotted hole joint

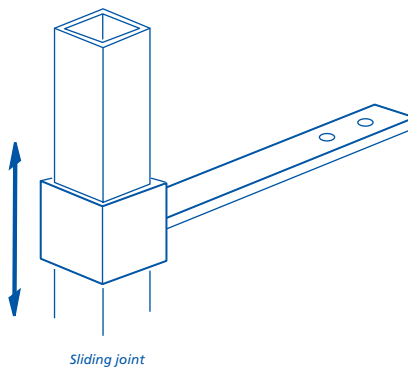

Sliding joint

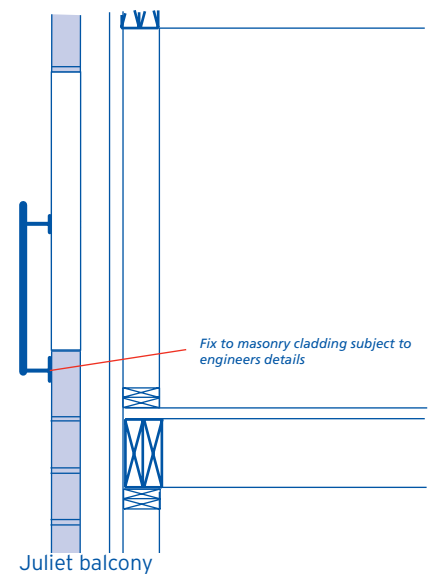

Juliet balcony

6.2

## LIGHTWEIGHT WALL CLADDING - JOINT AT EACH FLOOR LEVEL

(with and without insulation in cavity)

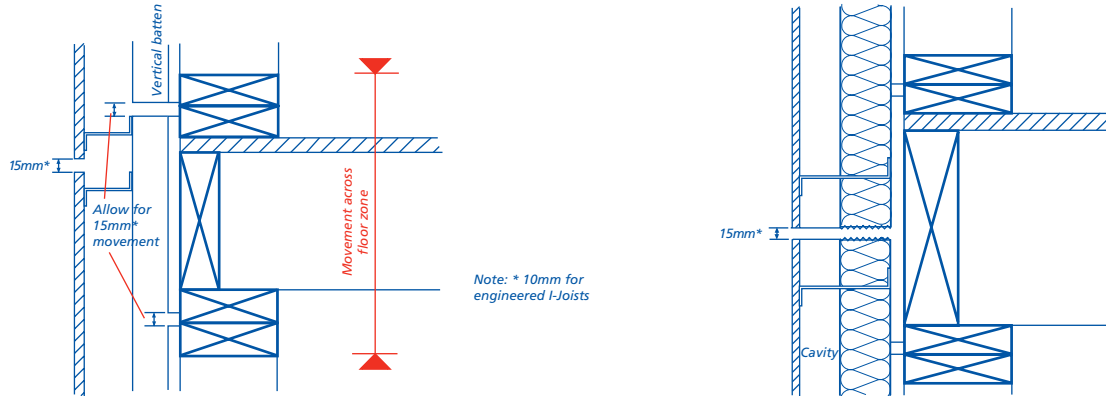

As built

After movement

## LIGHTWEIGHT CLADDING AND MASONRY PLINTH

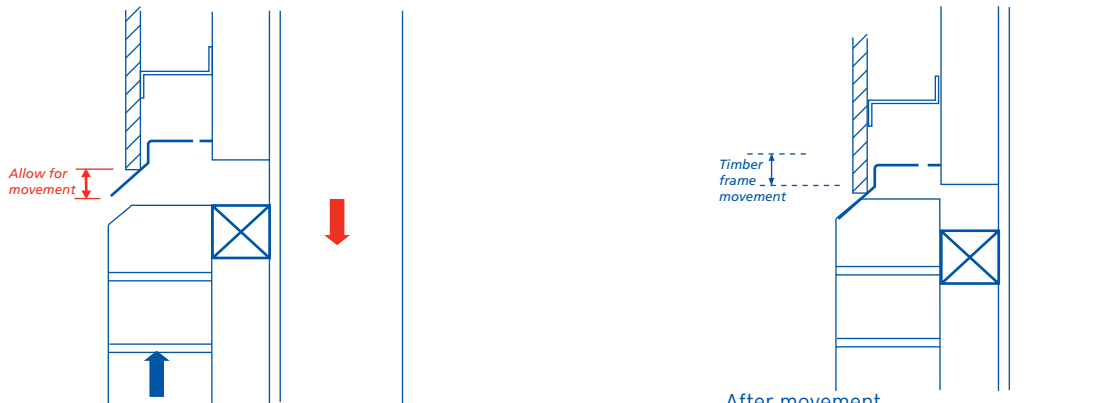

As built

After movement

## WALLS TO FLAT ROOF ABUTMENT

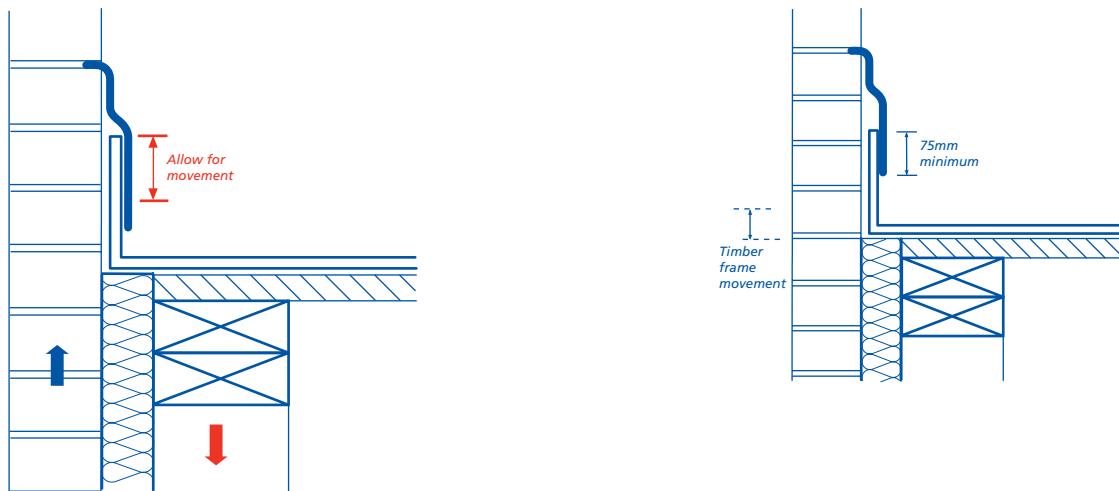

As built

After movement

6.2

## INDEX

<b>A</b>		<b>I</b>		<b>T</b>	
Anchoring frame	1, 5	Information	3	Timber	3
<b>B</b>		Insulation	2, 4, 6	Timber cladding	2
Balconies	14	<b>J</b>		Timber framing	2
Breather membranes	4, 5	Joints	1	<b>V</b>	
<b>C</b>		<b>L</b>		Vapour control layer	2, 4, 6
Cavities	2, 5	Loadbearing walls	1	Verge	12
Cavity barriers	3, 4, 6	<b>M</b>		<b>W</b>	
Certification	7	Membranes	2	Wall ties	2, 4, 6
Chimneys	11	Moisture	4	Window reveals	9
Cladding	5, 6, 10, 11, 15	Movement	3, 5	Window heads	10, 11
<b>D</b>		<b>N</b>		Window sill	11
Damp proof courses	1	Nails	4		
Differential movement	7, 8	<b>P</b>			
Drive through	13	Panels, fixing	5		
<b>E</b>		Plasterboard, fixing	5		
Eaves	12	Preservative treatment	2, 4		
Exterior cladding	2	Packing	7		
<b>F</b>		Prefabricated chimneys	3, 5		
Fire control	3, 6	<b>S</b>			
Fire-stops	3, 4, 7	Services	3, 7, 12		
Fixings	4, 5	Setting out	4		
Flat roof	15	Sheathing	4		
<b>H</b>		Stairs interface	11		
Holding down devices	4	Staples	4		
		Structural elements	1		
		Sole plates	7		



# Chapter 6.3

## Internal walls

---



# 6.3

## Internal walls

### CONTENTS

	Clause	Page
<b>DESIGN</b>		
Design standards	D1	1
Statutory requirements	D2	1
Loadbearing masonry walls	D3	1
Loadbearing timber walls	D4	2
Beams and lintels	D5	2
Non-loadbearing internal partitions	D6	2
Fire resistance	D7	2
Movement joints	D8	3
Sound insulation	D9	3
Damp-proofing	D10	4
Fireplaces and flues	D11	4
Provision of information	D12-D13	4
<b>MATERIALS</b>		
Materials standards	M1	4
Masonry materials	M2	5
Wall ties and related items	M3	5
Timber	M4-M5	5
Plasterboard	M6	5
Proprietary systems	M7	5
Damp-proof courses	M8	5
Sound insulation materials	M9	5
Fire-stopping materials	M10	6
Fireplaces and flues	M11	6
<b>SITWORK</b>		
Sitework standards	S1	6
Damp-proof courses	S2	6
Masonry partitions	S3	6
Timber stud partitions	S4	7
Proprietary partitions	S5	8
Separating walls	S6	8
Partitions to rooms containing a WC	S7	8
Walls providing fire resistance	S8	9
Chimneys, flues and linings	S9	9
<b>INDEX</b>		9

### SCOPE

This Chapter gives guidance on meeting the Technical Requirements and recommendations for internal walls, including separating walls and compartment walls.

## DESIGN STANDARDS

### 6.3 - D1 Design shall meet the Technical Requirements

Design that follows the guidance below will be acceptable for internal walls, including separating walls and compartment walls.

## STATUTORY REQUIREMENTS

### 6.3 - D2 Design shall comply with all relevant statutory requirements

Design should be in accordance with relevant Building Regulations and other statutory requirements.

## LOADBEARING MASONRY WALLS

### 6.3 - D3 Loadbearing masonry internal walls shall be designed to support and transfer loads to foundations safely and without undue movement

Structural design of masonry walls should be in accordance with BS EN 1996-1-1

Items to be taken into account include:

#### (a) provision of foundations

Any loadbearing wall should be provided with either:

- a foundation, or
- a means of support that transfers the load safely to a foundation.

Sleeper walls should be designed and constructed as described in Chapter 4.4 'Strip and trench fill foundations' (each section).

Where necessary, oversite concrete should be protected against sulfate attack by the use of a polyethylene sheet dpm, not less than 1200 gauge (0.3mm), (or 1000 gauge (0.25mm) if assessed in accordance with Technical Requirement R3) properly lapped.

Loadbearing walls built off a concrete groundbearing slab are acceptable only if the concrete forms part of a foundation which is designed by an Engineer in accordance with Technical Requirement R5.

Foundation design should take account of any site investigation or ground hazards.

#### (b) structural elements

Bricks and blocks should be selected in accordance with their intended use. The table below gives recommended strengths of bricks and blocks to be used in buildings up to 3 storeys high:

Height of wall	Minimum compressive strength of brick or block unit	
1 or 2 storeys	blocks	- 2.9N/mm <sup>2</sup>
	bricks	- 9.0N/mm <sup>2</sup>
Lowest storey of a 3 storey wall or where individual storeys exceed 2.7m	blocks	- 7.3N/mm <sup>2</sup>
	bricks	- 13.0N/mm <sup>2</sup> (unless calculations show that lower strengths are suitable)
Upper storeys of 3 storey wall	blocks	- 2.9N/mm <sup>2</sup>
	bricks	- 9.0N/mm <sup>2</sup>

#### (c) lateral restraint

Loadbearing walls, including separating walls should be provided with lateral restraint:

- at each floor level, and
- at the ceiling level below a roof.

Concrete floors provide adequate restraint if:

- they have a minimum 90mm bearing onto the wall, or
- they abut each side of the wall (provided that both floors are at, or about, the same level).

Restraint straps should be provided at 2m centres to each floor when:

- floors are not at, or near, the same level, and
- the floor span is parallel to the wall, and
- the floor is not built into the wall.

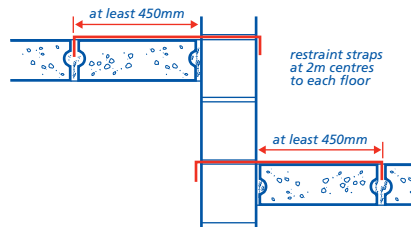

Timber joists with a minimum of 90mm bearing normally provide adequate lateral restraint.

Where timber joists are not built into a masonry wall, restraint should be provided at 2m centres by means of either:

- restraint type joist hangers to BS EN 845-1 with performance equivalent to a restraint strap, or
- restraint straps with a cross section of at least 30mm x 5mm.

Where restraint is required and restraint-type hangers are not used, straps should be:

- at least 300mm long on each joist
- fixed with four fixings to each joist
- not more than 2m apart.

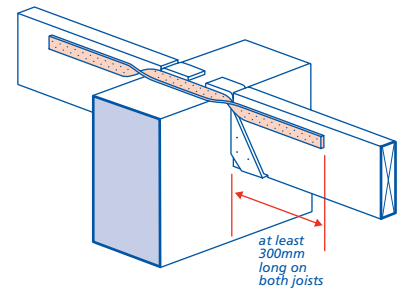
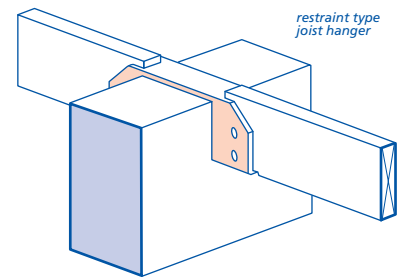

Where permitted, timber joists built into separating walls may provide lateral restraint but care should be taken to ensure that sound insulation and fire resistance requirements are also met. See Clauses D7 and D9.

#### (d) bonding and tying

Where a separating wall abuts an external wall they may be tied or bonded together.

Tied joints should be formed using expanded metal strip, wall ties or equivalent fixings, at maximum 300mm vertical centres.

The external wall cavity should be closed at the junction with the separating wall with a flexible cavity stop, unless the cavity is fully filled with built-in insulation (where permitted).

#### (e) movement joints

For guidance on the design of movement joints, reference should be made to Clause D8.

#### (f) wall ties for cavity separating walls

Normally, the two leaves of a masonry cavity separating wall should be tied together to provide structural stability. The type of tie and spacing should limit the sound transmission across the cavity. Reference should be made to Clause D9 for details.

In England and Wales, separating walls may be built in accordance with Robust Details "Resistance to the passage of sound".

# 6.3 Internal walls

## LOADBEARING TIMBER WALLS

### 6.3 - D4 Loadbearing timber internal walls shall be designed to support and transfer loads to foundations safely and without undue movement

Structural design of loadbearing timber walls should be in accordance with BS EN 1995-1-1

Structural timber should be specified according to the strength classes in BS EN 338, eg C16 or C24. When using the BS 4978 grading rules, the timber species should be in accordance with BS EN 1912 or strength class specified. The strength classes can then be determined from BS EN 338

Items to be taken into account include:

#### (a) provision of foundations

Foundations should be provided as for structural masonry walls (see Clause D3(a)).

#### (b) structural elements

Normally, individual studs, sills and headplates should be 38mm x 75mm. Larger timber section sizes may be required in order to achieve an adequate level of fire resistance. Stud spacing should be spaced at maximum 600mm centres.

A lintel and cripple studs should be provided to any opening except when the stud spacing is unaffected. Normally, multiple studs should be provided to support multiple joists.

Where internal walls are made up of panels, structural continuity should be maintained, for example by the use of a continuous top binder.

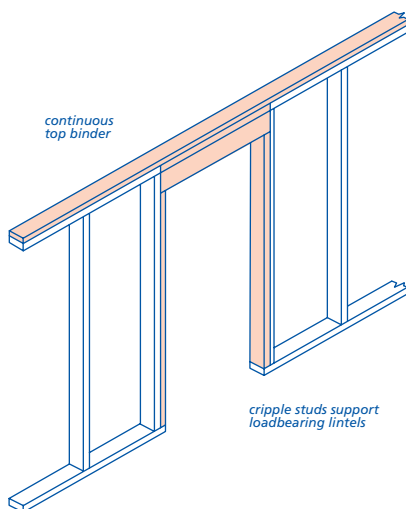

Framing joints should be secured with not less than two nails per joint.

#### (c) wall ties for cavity separating walls

For timber framed separating walls, ties should be specified in accordance with the system designer's recommendations. The

type of tie and spacing should limit sound transmission across the cavity.

To limit sound transmission, metal tie straps should be:

- not more than 3mm thick
- fixed below ceiling level
- spaced at least 1.2m apart horizontally.

Thicker ties, fixed at ceiling level or more closely spaced will increase sound transmission across the cavity.

## BEAMS AND LINTELS

### 6.3 - D5 Beams and lintels shall be adequate for their purpose

Items to be taken into account include:

#### (a) loads and spans

Loads and spans should be either in accordance with manufacturers' recommendations or designed by an Engineer in accordance with Technical Requirement R5.

#### (b) materials

Concrete or steel lintels are suitable for use in masonry walls. Timber lintels should not be used to support masonry.

Lintels should extend beyond each end of openings in masonry as follows:

Span [m]	Minimum length of bearing [mm]
Up to 1.2	100
Over 1.2	150

Where structurally necessary, padstones should be provided under the bearings of lintels and beams. Reference should be made to Chapter 6.5 'Steelwork support to upper floors and partitions'.

## NON-LOADBEARING INTERNAL PARTITIONS

### 6.3 - D6 Non-loadbearing partitions shall have adequate strength and be adequately supported

Items to be taken into account include:

#### (a) partition construction

The following constructions are acceptable:

- partitions of brick or block construction
- timber stud partitions using studs, sills and headplates nominally 63mm x 38mm. Studs should be spaced to suit the thickness of plasterboard used, as follows:
  - not more than 450mm spacing for 9.5mm boards
  - not more than 600mm spacing for 10mm to 20mm boards

- proprietary partitions of plasterboard, strawboard or other material, detailed and constructed in accordance with manufacturers' recommendations.

#### (b) movement joints

Reference should be made to Clause D8.

#### (c) method of supporting partition

Walls and partitions should be supported by the structural floor, not by a floating floor that incorporates a compressible layer, unless the material is specifically manufactured for that purpose.

Preferably, masonry partitions should be supported on:

- other masonry partitions or walls (wherever possible the design of dwellings should be such that first floor masonry partitions are a continuation of those on the ground floor)
- concrete floors
- steel or concrete beams.

Where steel or concrete beams are to be used, it may be necessary to use padstones at bearings.

Masonry partitions should not be supported by timber joists or beams, unless they have been designed by an Engineer in accordance with Technical Requirement R5.

The design should make allowance for the relatively flexible nature of the timber and the relatively rigid nature of masonry.

Where stud partitions or proprietary plasterboard partitions are supported by a timber floor, extra noggings or joists should be specified, unless it can be shown that the deck can transfer the load without undue movement.

Allowance should be made for the possible deflection of floors at the head of partitions to prevent the partition becoming loadbearing.

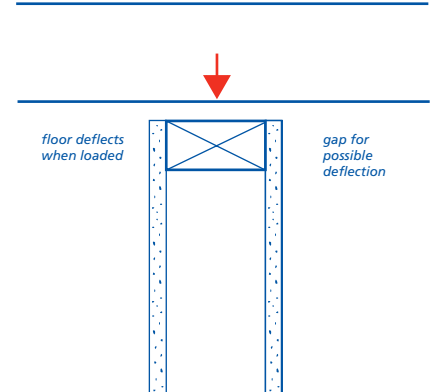

## FIRE RESISTANCE

### 6.3 - D7 Internal walls shall, where necessary, have adequate resistance to the spread of fire

The guidance below applies in England, Wales, Northern Ireland and the Isle of Man. In Scotland, reference should be made to statutory requirements.

Items to be taken into account include:

**(a) fire resistance of internal walls**

In houses up to 2 storeys, the following walls should be fire-resisting:

- loadbearing walls (half-hour minimum)
- separating walls (one hour minimum)
- walls between a house and an integral or attached garage (half-hour minimum).

In houses of 3 or more storeys, in addition to the above, the walls enclosing the staircase should have half-hour fire resistance.

For flats, the following walls should be fire-resisting:

- loadbearing walls within the flat (half-hour for up to 2 storeys, one hour for 3 or more storeys)
- separating walls, compartment walls and walls enclosing protected shafts, such as staircases (normally one hour)
- other walls enclosing hallways within flats, half-hour.

**(b) fire-stopping**

Fire-resisting walls should be fire-stopped or constructed to resist fire spread:

- at their perimeter
- at junctions with other fire-resisting walls, floors and roofs
- where openings are formed for doors, pipes, etc.

The following details should be designed carefully:

- the junction between a separating or compartment wall and a pitched roof or a flat roof
- where pipes and cables penetrate a fire-resisting wall (reference should also be made to Chapter 8.1 'Internal services' (Design and Sitework)).

The wall dividing an integral or attached garage and the floor above should act together to provide adequate resistance to fire spread. If there is either no ceiling or no floor to the space above the ceiling to the garage, vertical fire separation may be required.

When fire-stopping against timber construction, it is important to specify compressible material, such as mineral wool, to allow timber shrinkage to take place without affecting the fire-stopping.

**(c) provision of cavity barriers**

All internal walls of hollow or cavity construction, whether fire-resisting or not, should have cavity barriers installed at their perimeter and at junctions with fire-resisting floors and walls.

For cavity separating walls of masonry construction, the top of the wall needs to be closed for fire resistance.

Timber framed separating walls should be specified with cavity barriers of wire reinforced mineral wool at junctions with floors and ceilings. Reference should be

made to Chapter 6.2 'External timber framed walls' for further information.

## MOVEMENT JOINTS

**6.3 - D8 Masonry walls shall, where necessary, be provided with movement joints**

Movement joints should be provided in straight unbroken lengths of wall as shown in the following table:

Type of brick or block	Joint width [mm]	Normal spacing
Clay brick	16	12m (15m max)
Calcium silicate brick	10	7.5 to 9m
Concrete block and brick	10	6m

Movement joints in foundations should be continued through the superstructure.

## SOUND INSULATION

**6.3 - D9 Internal walls shall, where necessary, have adequate resistance to the transmission of sound**

Items to be taken into account include:

**(a) all separating walls**

In England and Wales, separating walls may be built in accordance with Robust Details Part E "Resistance to the passage of sound".

For details of separating walls in timber frame construction, reference should be made to Chapter 6.2 'External timber framed walls'.

To ensure an adequate level of sound insulation for masonry separating walls:

- statutory requirements may permit the building in of joist ends into separating walls. Where permitted there should be a mortar joint around the joist perimeter and the face of the joint pointed with silicone sealant
- all joints in the separating wall should be fully filled with mortar
- flexible cavity stops should be provided at the junction of separating walls with external walls
- avoid any reduction in the thickness of masonry, but where this is unavoidable, eg to accommodate electrical sockets, positions on opposite sides of the separating wall should be staggered.

Care should be taken when specifying dry lining to masonry separating walls. The thickness of plasterboard layers, the method of fixing and sealing may be critical. For fixing details, reference should be made to BS 8212.

**(b) cavity separating walls**

Cavity separating walls should be constructed so that any external cavity wall insulation placed by blown or pumped

methods, where permitted, cannot enter the separating wall cavity.

In masonry cavity separating walls, where the cavity is up to 75mm, flexible wall ties should be used, such as:

- butterfly type ties, or
- ties assessed for the purpose.

Where structural design permits, the omission of ties will enhance sound insulation.

Ties should be spaced 900mm horizontally and 450mm vertically. Closer spacing will increase sound transmission. Wider spacing may impair structural stability. Rigid ties transmit sound more readily than flexible ties.

Chases for services should be kept to a minimum and be well filled with mortar.

**(c) flanking transmission**

The construction of the flanking wall, including the position of openings in it, will have an impact on sound transmission. The requirements of statutory regulations should be followed.

**(d) partitions to rooms containing a WC**

The guidance below applies in Scotland, Northern Ireland and the Isle of Man. In England and Wales reference should be made to statutory requirements.

### PARTITION PERFORMANCE

Any partition between a room containing a WC and a living room, dining room, study or bedroom should have a weighted sound reduction index of not less than 38dB over the frequency range 100-3150Hz, when tested in accordance with BS EN ISO 140-4. This does not apply to a partition between a WC and a bedroom where the WC forms an en-suite facility to the bedroom.

The following methods of construction will achieve the performance level stated above.

### BLOCKWORK PARTITIONS

Blocks having a density of not less than 600kg/m<sup>3</sup> finished on both sides with 13mm of plaster are acceptable.

Blockwork should be tied in every course to adjoining walls, with the joints filled solid.

For details of bonding and tying, reference should be made to Sitework clause 6.3 - S3(d).

### TIMBER STUDWORK

Timber studwork is acceptable if used with one of the following combinations of materials:

# 6.3

## Internal walls

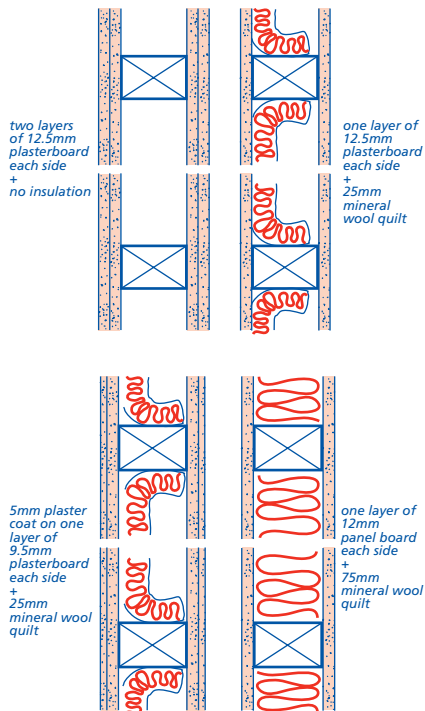

Other forms of timber studwork construction will be acceptable provided the criteria given under PARTITION PERFORMANCE is achieved and independent evidence of performance is available at the request of NHBC.

Where two thicknesses of board are used, the joints should be staggered and the joints in the outer layer properly filled.

Top plates, bottom plates and end studs should be secured and sealed to the adjoining structure so that sound paths cannot develop following shrinkage and/or deflection of the timber.

### PROPRIETARY PARTITIONS

Certain proprietary partition systems meet the required standard. The partition manufacturer should have independent test evidence of the system's performance.

### DAMP-PROOFING

**6.3 - D10 Internal walls shall be designed to provide adequate resistance to moisture from the ground**

Loadbearing walls built off foundation walls should have a dpc at their base at least the width of the wall. The dpc should link with any adjoining dpm.

Where steps are necessary in the ground floor slab, a dpc should be incorporated as a continuous link between the upper and lower dpcs. The vertical part of the dpc should be protected from damage during construction.

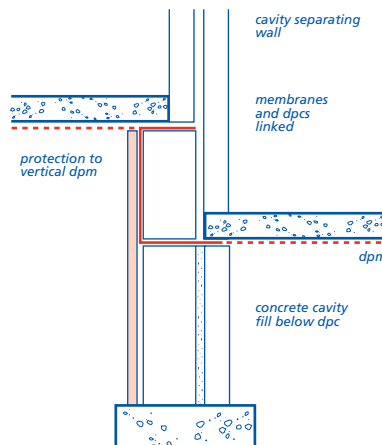

Dpcs should be included below the following:

- non-loadbearing partitions built off an in-situ ground slab with a dpm applied to the top of the slab

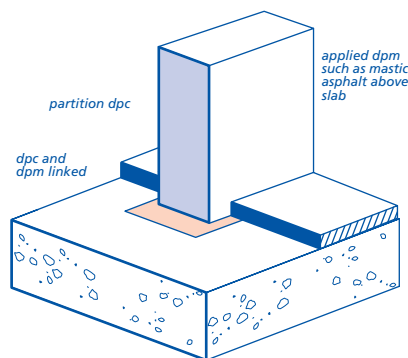
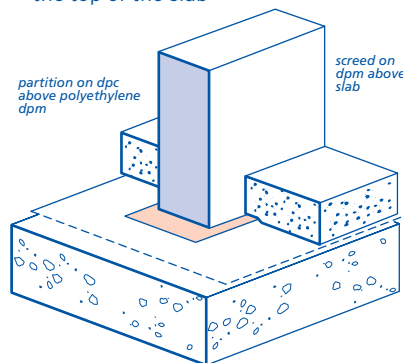

- partitions that may be adversely affected by residual damp (eg stud partitions) built off any type of concrete floor.

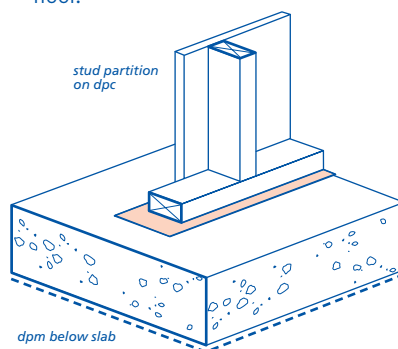

### FIREPLACES AND FLUES

#### 6.3 - D11 Fireplaces and flues

See Chapter 6.8 'Fireplaces, chimneys and flues'.

### PROVISION OF INFORMATION

**6.3 - D12 Designs and specifications shall be produced in a clearly understandable format and include all relevant information**

Drawings should give full information, including:

- wall layout, with all dimensions shown
- position and size of openings and lintels
- details at junctions, indicating fire-stopping where applicable
- details of wall constructions and materials, ties and restraints
- details of foundations where required.

**6.3 - D13 All relevant information shall be distributed to appropriate personnel**

Ensure that design and specification information is issued to site supervisors and relevant specialist subcontractors and/or suppliers.

Where proprietary components are to be used, manufacturers usually have specific requirements for fixing and/or assembly of their products. This information should also be made available for reference on site so that work can be carried out satisfactorily in accordance with the design and specification.

### MATERIALS STANDARDS

**6.3 - M1 All materials shall:**  
**(a) meet the Technical Requirements**  
**(b) take account of the design**

Materials that comply with the design and the guidance below will be acceptable for internal walls, including separating walls and compartment walls.

Materials for internal walls should comply with all relevant standards, including those listed below. Where no standard exists, Technical Requirement R3 applies (see Chapter 1.1 'Introduction to the Standards and Technical Requirements').

References to British Standards and Codes of Practice include those made under the Construction Products Directive (89/106/EEC) and, in particular, appropriate European Technical Specifications approved by a European Committee for Standardisation (CEN).



## MASONRY MATERIALS

### 6.3 - M2 Masonry shall comply with relevant standards

Items to be taken into account include:

#### (a) precast concrete blocks

Concrete blocks should comply with BS EN 771.

When used in loadbearing partitions, blocks should have the minimum compressive strength required by the design. The table below gives recommended strengths of blocks to be used in specific cases:

Height of wall	Minimum compressive strength of block unit
1 or 2 storeys	blocks - 2.9N/mm <sup>2</sup>
Lowest storey of a 3 storey wall or where individual storeys exceed 2.7m	blocks - 7.3N/mm <sup>2</sup> (unless calculations show that lower strengths are suitable)
Upper storeys of 3 storey wall	blocks - 2.9N/mm <sup>2</sup>

Where buildings are more than 3 storeys in height, masonry should be designed in accordance with Technical Requirement R5 using the block strength specified by the designer.

The maximum loadbearing capacity of the wall should not exceed the recommendations of the manufacturer.

In some partitions to WC compartments and all separating walls, blocks should have at least the minimum density required by the design in order to achieve the required sound insulation.

Where special blocks/pipes are used for flues, the manufacturer's recommendations should be checked. Special materials may be required around the blocks/pipes.

#### (b) bricks

Bricks should comply with the relevant British Standards:

- clay bricks should comply with BS EN 771-1
- calcium silicate bricks should comply with BS EN 771-2
- concrete bricks should comply with BS EN 771-3.

When used in a separating wall, bricks should have at least the minimum density required by the design. A lighter brick may not provide a suitable level of sound resistance.

For bricks suitable for use in chimneys reference should be made to Chapter 6.8 'Fireplaces, chimneys and flues'.

#### (c) mortar

A mortar of 1 : 1 : 5½, cement : lime : sand, with plasticiser is suitable for both internal and external walls.

Unless otherwise specified by the brick or block manufacturer, ordinary Portland cement to BS EN 197 may be used. Sulfate-resisting Portland cement should be used, where necessary (see Chapter 6.1 'External masonry walls' (Materials)).

Admixtures, retarded mortars and pre-mixed mortars may be used in accordance with the manufacturer's recommendations, provided those of the masonry manufacturer agree.

## WALL TIES AND RELATED ITEMS

### 6.3 - M3 Walls ties and related items shall be of the appropriate type and strength and shall have adequate durability

#### WALL TIES FOR SEPARATING WALLS

Wall ties should either:

- be butterfly type, or
- have been tested to show that their design meets with statutory requirements.

Wall ties for timber frame separating walls should be not more than 40mm x 3mm in cross section.

#### HANGERS, STRAPS, ETC

Joist hangers, restraint straps, bond ties, etc should be protected against corrosion. Ferrous metals with the following levels of protection are acceptable:

- post-galvanizing to BS 729, or
- pre-galvanizing to BS 2989.

Restraint straps for use in masonry construction should have a minimum cross section of 30mm x 5mm.

## TIMBER

### 6.3 - M4 Timber shall be of the appropriate grades and sizes to support the imposed loads

Preferably, regularised timber should be used for stud partitions. Structural timber should be specified according to the strength classes in BS EN 338, eg C16 or C24. When using the BS 4978 grading rules, the timber species should be included in accordance with BS EN 1912 or class strength specified. The strength class can then be determined from BS EN 338.

Finger joints should comply with BS EN 385 and timber for dry lining with BS 8212.

### 6.3 - M5 Timber shall have a suitable moisture content

To minimise drying shrinkage, timber should have a moisture content not greater than 20%.

Structural softwood for internal use should be dry graded to BS 4978 and marked 'DRY' or 'KD'.

## PLASTERBOARD

### 6.3 - M6 Plasterboard shall be of a suitable thickness for its intended use

Plasterboard should be to BS 1230.

Plasterboard thickness should be:

- 9.5mm for stud spacing up to 450mm
- 12.5mm for stud spacing up to 600mm.

For sound-resisting walls (separating walls and walls to WC compartments), the correct thickness, number of layers of plasterboard sheets and sealing should be specified (see Design clause 6.3 - D9).

Tapered edge boards should be used where the plasterboard is to be jointed only before decoration.

Dry lining systems should comply with BS 8212. Reference should be made to Chapter 8.2 'Wall and ceiling finishes' (each section) for further details.

## PROPRIETARY SYSTEMS

### 6.3 - M7 Prefabricated proprietary partition systems shall be suitable for their purpose

Proprietary partitions should be specified in accordance with the manufacturer's recommendations.

## DAMP-PROOF COURSES

### 6.3 - M8 Materials for damp-proofing shall adequately resist the passage of moisture

Materials which are acceptable for use as dpcs include:

- bitumen to BS 6398
- polyethylene to BS 6515
- proprietary materials assessed in accordance with Technical Requirement R3.

Dpcs should be not less than the width of the wall or partition.

## SOUND INSULATION MATERIALS

### 6.3 - M9 Materials used for sound insulation shall be of a suitable thickness and density

Normally, mineral wool quilt should be used for acoustic insulation in partitions. The thickness and density should be as required by the design.



# 6.3 Internal walls

## FIRE-STOPPING MATERIALS

### 6.3 - M10 Fire-stopping materials shall be suitable to resist the passage of fire

Suitable fire-stopping materials include:

- mineral wool
- cement mortar
- gypsum plaster
- intumescent mastic or preformed strip
- proprietary sealing systems (particularly those designed for service penetrations) assessed in accordance with Technical Requirement R3 to maintain the fire resistance of the wall.

## FIREPLACES AND FLUES

### 6.3 - M11 Fireplaces and flues

See Chapter 6.8 'Fireplaces, chimneys and flues'.

## SITWORK STANDARDS

### 6.3 - S1 All sitework shall:

- meet the Technical Requirements
- take account of the design
- follow established good practice and workmanship

Sitework that follows the design and the guidance below will be acceptable for internal walls, including separating walls and compartment walls.

## DAMP-PROOF COURSES

### 6.3 - S2 Damp-proof courses shall be installed to prevent moisture entering the building

A dpc should be provided below all loadbearing walls built off foundation walls. The dpc should be linked with any adjoining dpm.

The dpm may be either continuous or formed by two separate overlapping pieces.

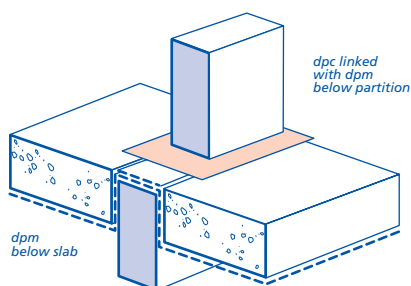

Dpcs should be provided below timber partitions where directly fixed to floor slabs, even if there is a dpm beneath the slab. This is to prevent residual moisture in the concrete affecting the timber.

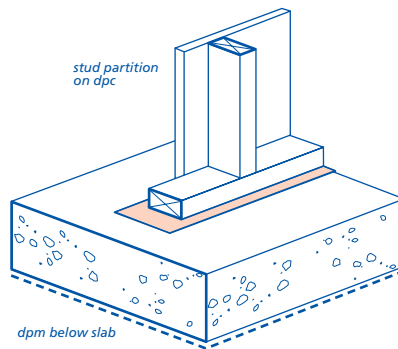

A dpc should be provided below all internal walls where the dpm is applied to the top surface of the slab.

The dpcs should be at least the width of the partition. Where dpcs join, the lap should be at least 100mm.

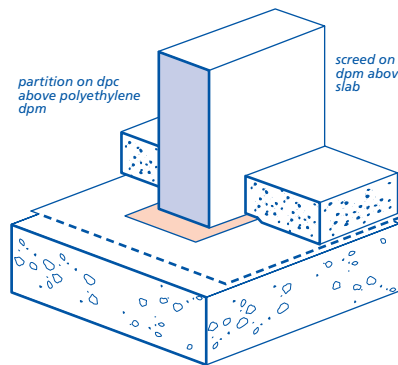

## MASONRY PARTITIONS

### 6.3 - S3 Construction of masonry internal walls shall ensure adequate stability

Items to be taken into account include:

- setting out and workmanship**  
Partitions should be accurately set out in accordance with the design.

All work should be reasonably plane and true. Walls should be plumbed and courses levelled by using lines and spirit levels.

Openings should be formed to the correct size and shape. Templates should be used, where necessary.

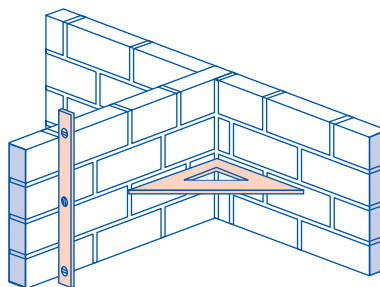

### (b) construction sequence

Walling should be constructed in lifts/stages to prevent distortion of wall panels during construction.

### (c) mortar mix and joints

#### MIX

Make sure the correct mix is used. A mortar of 1 : 1 : 5½, cement : lime : sand, with plasticiser is suitable for both internal and external walls.

Unless otherwise specified, ordinary Portland cement may be used. Sulfate-resisting Portland cement should be used, where necessary (see Chapter 6.1 'External masonry walls' (Sitework)).

Mixers should be maintained and cleaned to function properly.

Mortar should be used within 2 hours, unless it is a retarded mortar. Mortar should not be re-tempered after setting has commenced.

#### RETARDED MORTAR

Retarded mortar should not be used beyond the time specified by the supplier.

Retarded mortar should not be used during cold weather.

#### ADDITIVES

Where plasticisers or other additives are to be used, the manufacturer's instructions should be followed. An air entraining agent can help reduce frost damage but it is not an anti-freeze. The recommended quantity of air entraining agent should be carefully measured for each batch in accordance with the manufacturer's instructions.

#### MORTAR JOINTS

All bricks and blocks should be laid on a full bed of mortar.

All perpend should be solidly filled.

If walls are to be finished with wet plaster, joints should be raked out square to a shallow depth to provide a key.

For dry lining, mortar joints should be struck off flush.

For information on dry lining masonry walls, reference should be made to Chapter 8.2 'Wall and ceiling finishes' (Sitework).

### (d) bonding and tying

A regular bonding pattern should be maintained. All masonry walls and partitions should be fully bonded or tied, as required by the design.

Either:

- tooth every alternate course, or
- tie with expanded metal or equivalent, at centres not exceeding 300mm vertically.

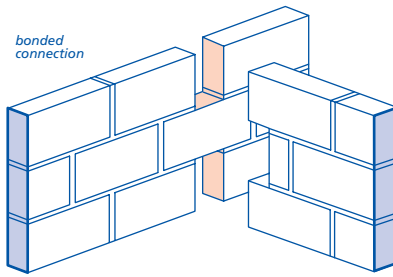

bonded connection

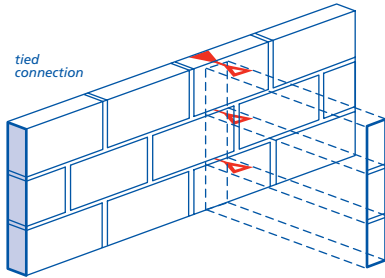

tied connection

Joist filling should be brick or blockwork, without excessive mortar joints. Bricks and blocks should not be mixed.

To avoid cracking, bricks and blocks or blocks of different types should not be mixed in the same wall.

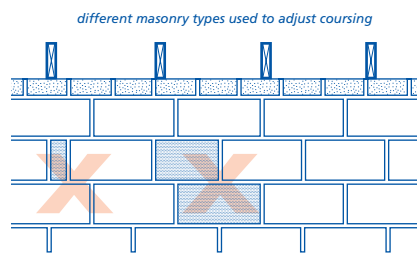

different masonry types used to adjust coursing



incorrect use of different masonry types

### (e) chasing for services

Chases can reduce the sound insulation value of a wall and should be cut only where required by the design. Impact power tools that can damage the wall should not be used.

The depth of horizontal chases should not exceed one-sixth the thickness of the single leaf, and vertical chases, one-third the thickness. Hollow blocks should not be chased, unless specifically permitted by the manufacturer.

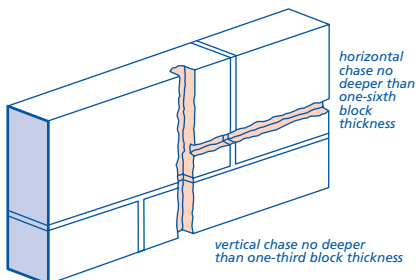

horizontal chase no deeper than one-sixth block thickness

vertical chase no deeper than one-third block thickness

### (f) size, location and support of lintels and beams

Lintels should be the correct size for the opening and have the correct bearing at each end:

Span [m]	Minimum bearing [mm]
Up to 1.2	100
Over 1.2	150

Long lintels may require padstones. Lintels should bear on a full block where possible and be installed level on a solid bed of mortar. Soft or non-durable packing should not be used.

Small pieces of cut bricks or blocks should not be used around lintel bearings. Concrete lintels should be the right way up.

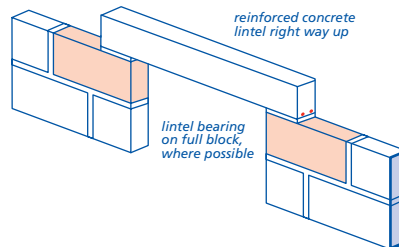

reinforced concrete lintel right way up

lintel bearing on full block, where possible

Where steel beams are to be used, reference should be made to Chapter 6.5 'Steelwork support to upper floors and partitions' (Sitework) for guidance on steel beam sizes and the need for padstones.

### (g) restraint strapping

Joists built into masonry walls provide adequate lateral restraint.

Restraint straps may be required by the design. If so, they should be fitted before new masonry is built above.

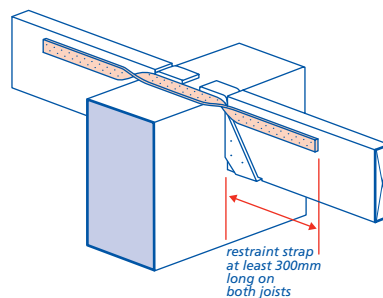

restraint strap at least 300mm long on both joists

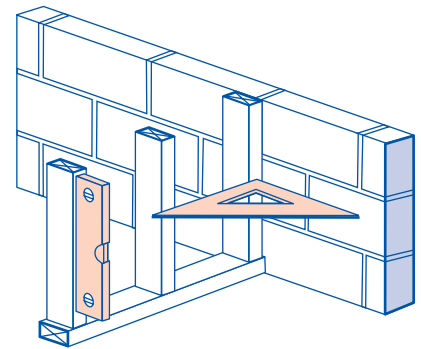

Studs should be spaced at centres to suit the plasterboard thickness. Extra studs should be provided at openings, as required by the design.

### (b) size of timber members

Loadbearing timber partitions should be constructed in accordance with the design. Unless designed otherwise, the minimum specification for all partitions should be:

- sill and head plates 63mm x 38mm
- studs 63mm x 38mm at maximum 600mm centres
- framing joints secured with not less than 2 nails per joint
- blocking/nogging for support of plasterboard 43mm x 38mm
- blocking/nogging for other purposes 63mm x 38mm.

### (c) support and fixings

Partitions should be firmly fixed to each other and to abutting walls. Noggings or extra studs should be used, where necessary.

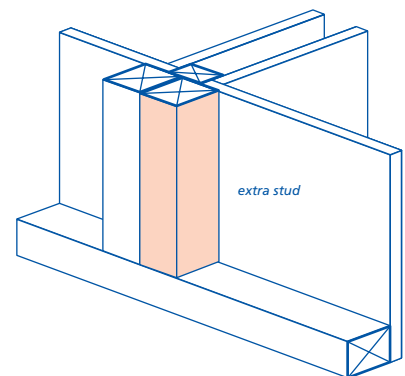

extra stud

Partitions should be fixed at head and base to noggings or joists.

## TIMBER STUD PARTITIONS

### 6.3 - S4 Construction of timber stud internal walls shall ensure adequate stability

Items to be taken into account include:

#### (a) setting out and workmanship

Partitioning should be correctly positioned, square and plumb.

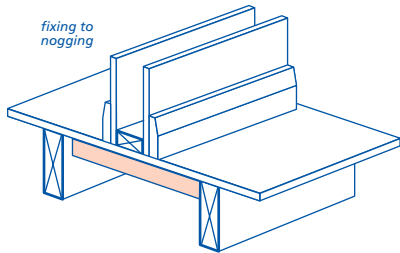
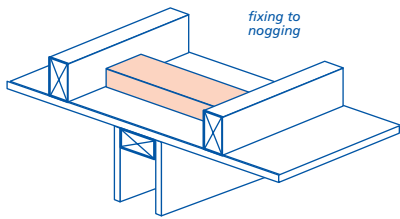

PARTITION PARALLEL TO JOIST

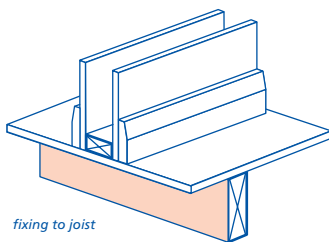
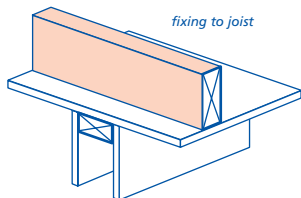

PARTITION AT RIGHT ANGLES TO JOIST

Internal partitions should not be wedged against ceiling joists or roof trusses. This does not allow for ceiling deflection/movement and can damage the ceiling boards.

Partitions should not be over-wedged at floor level. This could damage floor boarding.

Noggings should be provided to support fittings, such as radiators, wall mounted boilers, sanitary fittings, kitchen units, etc.

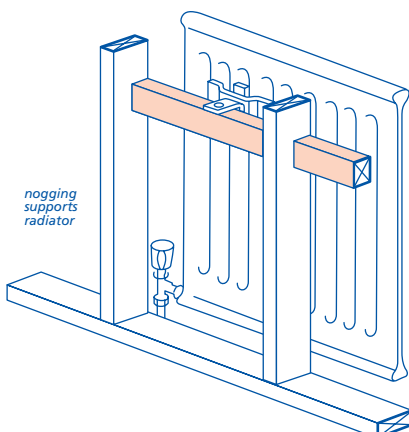

Fixing and finishing plasterboard partitions should be in accordance with Chapter 8.2 'Wall and ceiling finishes' (Sitework).

### PROPRIETARY PARTITIONS

**6.3 - S5 Proprietary partitions shall be erected in accordance with manufacturers' recommendations**

Partitioning should be correctly positioned, square and plumb. The manufacturer's recommended construction sequence should be followed.

Timber or other additional fixings should be provided for radiators, electrical outlets, switches and the like.

### SEPARATING WALLS

**6.3 - S6 Construction of separating walls shall ensure adequate sound insulation**

#### MASONRY SEPARATING WALLS

The correct density of block should be used. Holes, voids, even hairline cracks, can significantly reduce the effectiveness of a sound-insulating wall.

To maintain sound insulation:

- fully fill all mortar beds and perpend
- use only butterfly or other approved wall ties for cavities up to 75mm wide
- space wall ties 900mm minimum horizontally and 450mm minimum vertically
- stagger the positions of electrical socket outlets on opposite sides of separating walls
- tie in or tooth bond to adjoining walls to improve rigidity of separating wall
- where joist ends are built into separating walls fully fill the spaces around the joists with mortar and point around the joist perimeter with silicone sealant as required by the design
- chases for services should be well filled with mortar.

Solid separating walls should be taken through the inner leaf of a cavity external wall using metal ties to provide rigidity. However, if the same blocks are used for both walls, tooth bonding is acceptable.

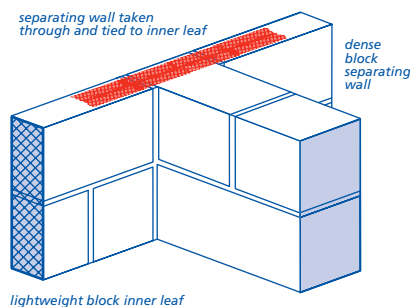

#### TIMBER SEPARATING WALLS

The design details should be carefully followed. There should be no gaps in the:

- mineral wool quilt
- plasterboard layers
- fire-stopping.

Services should not penetrate the plasterboard layers. They should be fixed in front of the plasterboard.

#### PARTITIONS TO ROOMS CONTAINING A WC

**6.3 - S7 Partitions to rooms containing a WC shall provide adequate sound insulation, where required by the design**

The guidance below applies in Scotland, Northern Ireland and the Isle of Man. In England and Wales the design should be checked to see how sound insulation is to be achieved.

A partition between a room containing a WC and a living room, dining room, study or bedroom (except where the WC is en-suite) should have adequate sound insulation.

Most masonry partitions provide adequate sound insulation without additional treatment.

Some methods of providing adequate sound insulation with a timber stud partition are shown below:

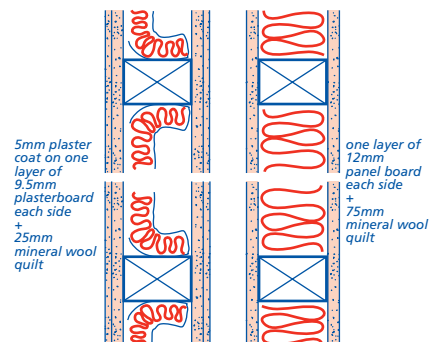
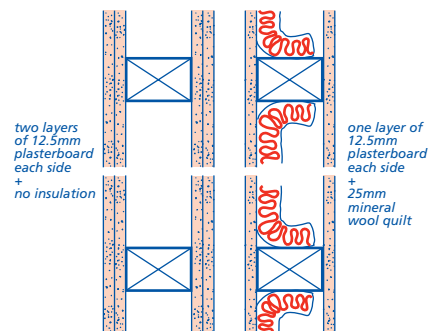

Where two layers of plasterboard are used, the joints should be staggered and the joints in the outer layer properly filled.

Proprietary plasterboard partitions usually need an additional layer of plasterboard to one or both sides of the partition to provide adequate sound insulation.

## WALLS PROVIDING FIRE RESISTANCE

### 6.3 - S8 Internal walls shall, where required, have adequate resistance to fire spread

Items to be taken into account include:

#### (a) separating wall construction

Junctions between separating walls and roofs should be firestopped to the underside of the tiling to prevent fire spreading between dwellings.

The separating wall should stop about 25mm below the top of adjacent roof trusses.

Soft packing, such as mineral wool, should be used above and below the roofing underlay, to allow for movement in roof timbers and prevent 'hogging' of the tiles.

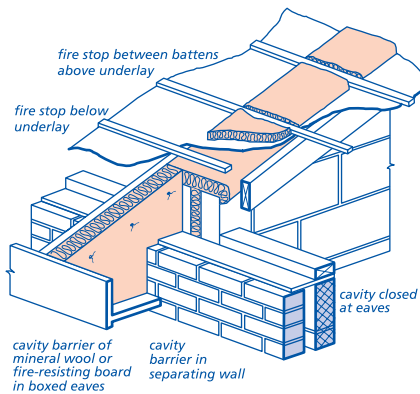

It is important that a cavity barrier is provided within boxed eaves. The cavity barrier should be wire reinforced mineral wool blanket, at least 50mm thick, nailed to the rafter and carefully cut to shape to fully seal the boxed eaves.

#### (b) penetration of fire-resisting walls by services

Pipes, cables and ducting should be firestopped where they pass through fire-resisting walls, including:

- separating walls
- compartment walls
- walls to ducts serving flats.

The design requirements for firestopping should be checked and making good completed neatly.

## CHIMNEYS, FLUES AND LININGS

### 6.3 - S9 Construction of chimneys, flues and linings

See Chapter 6.8 'Fireplaces, chimneys and flues'.

# 6.3

## Internal walls

### INDEX

<b>A</b>		<b>J</b>		<b>S</b>	
Additives	6	Joints	6	Separating walls	1, 2, 3, 5
<b>B</b>		Joist hangers	5	Services	7, 9
Beams	7	<b>L</b>		Setting out	6, 7
Blockwork	3	Lateral restraint	1	Sound insulation	3, 5
Bonding	1, 6	Lintels	7	Studwork	3
Bricks	5	<b>M</b>		Support	2, 7
<b>C</b>		Masonry	5, 6, 8	<b>T</b>	
Cavity barriers	3	Moisture resistance	4, 5, 6	Timber	5
Cavity walls	1, 3	Mortar	5, 6	Timber stud partitions	7
Chasing	7	Movement joints	1, 2, 3	Timber walls	2, 8
Chimneys	9	<b>P</b>		Tying	1, 6
Concrete blocks	5	Partitions	2, 3, 4, 6	<b>W</b>	
<b>D</b>		Plasterboard	5	Wall ties	1, 2, 5
Damp proofing	4, 6	Precast blocks	5	WCs	3, 8
Durability	5	Proprietary systems	5	Workmanship	6, 7
<b>F</b>		<b>R</b>			
Fireplaces	4, 6	Restraint straps	5, 7		
Fire stopping	3, 6				
Fixings	4, 7				
Flanking transmission, sound	3				
Flues	4, 6, 9				
Foundations	1, 2				

# Chapter 6.4

## Timber and concrete upper floors

---



# 6.4 Timber and concrete upper floors

## CONTENTS

<b>DESIGN</b>	Clause	Page
Design standards	D1	1
Statutory requirements	D2	1
Upper floor design	D3	1
Timber floor joists	D4	1
Trimmer joists	D5	2
Strutting of floor joists	D6	2
Joist hangers	D7-D8	2 - 3
Joist support at separating walls	D9	3
Restraint strapping	D10	3
Structural steel in floors	D11	3
Fire spread	D12-D13	3
Floor decking	D14	4
Concrete floors	D15	4
Floors between dwellings	D16-D17	4
Provision of information	D18-D19	4

## **MATERIALS**

Materials standards	M1	4
Timber floors	M2-M4	4
Joist hangers and restraint straps	M5	5
Strutting	M6	5
Floor decking	M7	5
Sound insulation	M8	5
Structural steel in floors	M9	5
Concrete and reinforcement	M10	5
Proprietary systems	M11	5

## **SITWORK**

Sitework standards	S1	5
Timber floors	S2	5
Joist hangers	S3-S4	6
Trimmed and trimming joists	S5-S6	6 - 7
Multiple joists	S7	7
Strutting of floors	S8	8
Notching and drilling	S9	9
Restraint strapping	S10-S12	9 - 10
Overlapping and butted joists	S13	10
Floor decking: general	S14-S16	10
Softwood boarding	S17	11
Chipboard flooring	S18-S19	11
Oriented strand board flooring	S20	11
Plywood flooring	S21	11
Other floor decking	S22	12
Floors between dwellings	S23	12
Concrete floors	S24-S25	12
In-situ concrete	S26	12
Precast concrete	S27	12
Fire-stopping	S28	13

## **APPENDIX 6.4-A**

Span tables for timber floor joists	13
-------------------------------------	----

## **INDEX**

16

## SCOPE

This Chapter gives guidance on meeting the Technical Requirements and recommendations for the construction of timber and concrete upper floors.



## DESIGN STANDARDS

### 6.4 - D1 Design shall meet the Technical Requirements

Design that follows the guidance below will be acceptable for timber and concrete upper floors.

## STATUTORY REQUIREMENTS

### 6.4 - D2 Design shall comply with all relevant statutory requirements

Design should be in accordance with relevant Building Regulations and other statutory requirements.

## UPPER FLOOR DESIGN

### 6.4 - D3 Upper floors shall be designed to support and transmit loads safely to the supporting structure without undue deflection

Items to be taken into account include:

#### (a) dead and imposed loads

The dead loads should include the weight of the following:

- floor structure, decking and finishes
- ceilings and applied finishes
- walls and partitions supported by the floor
- permanent fixtures such as boilers, watertanks, etc.

Imposed loads are the variable loads imposed when the building is in use. They include the weight of furniture and people. BS EN 1991-1-1 recommends an imposed loading allowance of 1.5kN/m<sup>2</sup> for self contained dwellings.

Where the design includes communal areas serving flats or maisonettes, refer to BS EN 1991-1-1 for recommended imposed loads.

Information concerning balconies is given in Chapter 7.1 'Flat roofs and balconies' (Design and Sitework).

#### (b) supporting structure

The floor structure should have an adequate bearing on the supporting structure. Timber joists should normally have a minimum bearing as shown in the table.

Type of timber joist	Minimum bearing [mm]	
	End support	Intermediate support
Solid joist on masonry walls	90 (75)	90 (75)
Solid joist on timber wall plate	75	75
I-joist	90 (45)	90
Metal web joist	90 (75)	90

#### Note

Figures in brackets should only be used when the joist is not providing restraint to the wall.

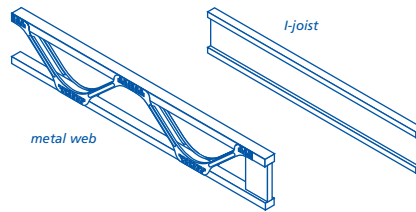

The support reaction due to dead and imposed loads on the floor should not exceed the recommended value specified by the manufacturers of I-joists and metal web joists.

Where necessary, I-joists should have web stiffeners at the locations of concentrated loads in accordance with the manufacturer's recommendations.

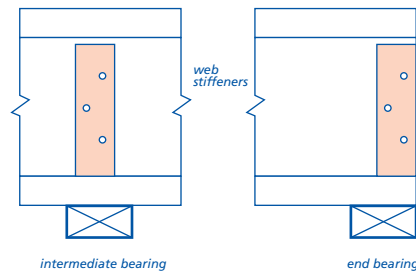

Metal web joists should have uprights at the supports between the flanges held in place by punched metal plate fasteners. Other support options are either top or bottom chord (flange) support, designed by the manufacturer.

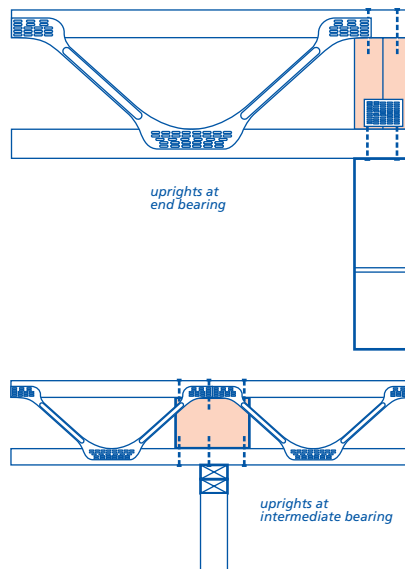

Joists may be supported on joist hangers or on internal load bearing walls. Where permitted they may be built into the inner leaf of an external cavity wall. Where joists are built into the inner leaf care should be taken to ensure air-tightness. Where solid timber joists are built into solid external walls, they should be pre-treated with preservative in accordance with Chapter 2.3 'Timber preservation (natural solid

timber)' (Design). I-joists and metal web joists should not be built into solid external walls.

Concrete floors should normally have a minimum bearing of 90mm on masonry walls.

## TIMBER FLOOR JOISTS

### 6.4 - D4 Floor joists shall be adequate for the spans and imposed loads

Items to be taken into account include:

#### (a) design

Structural timber for solid joists is normally specified as strength Class C16 or C24. Tables giving the permitted clear span for joists of strength Class C16 and C24 are given in the TRADA Technology Ltd publication "Span tables for solid timber members in floors, ceilings and roofs (excluding trussed rafter roofs) for dwellings" reproduced in Appendix 6.4-A.

I-joists and metal web joists should be specified in accordance with the manufacturer's instructions and the following deflection limits based on total dead and imposed loads for combined bending and shear; 0.003 times the span with a maximum deflection of 14mm if strutting is provided or 12mm if strutting is not provided.

I-joists and metal web joists should not be used in situations where any part of the joist is exposed to external conditions.

#### (b) joist sizes

Solid timber joist sizes are given in the span tables in BS 8103-3. Where the tables do not apply or where there are concentrated loads, floor joists should be designed by an Engineer in accordance with Technical Requirement R5.

Regularised timber is recommended for floor joists. The section sizes in the tables reproduced in Appendix 6.4-A should be regularised, or be ALS or CLS to enable floors and ceilings to be level.

I-joists and metal web joists should be specified in accordance with manufacturers' instructions.

#### (c) joist spacing

Joists should not be spaced at centres greater than 600mm.

When planning joist spacings, a clearance of 25mm to 75mm between the first joist and the wall face should be allowed. This helps when installing services and fixing floorboards.

#### (d) support of lightweight partitions

Multiple solid timber joists supporting lightweight non-loadbearing partitions running parallel to the joists should be suitably fixed together (see Sitework clause 6.4 -S7).

# 6.4 Timber and concrete upper floors

I-joists and metal web joists should either:

- be positioned centrally below a non-loadbearing partition (if necessary they can be doubled or tripled up in accordance with the manufacturer's instructions), or
- support the weight of the non-loadbearing partition by noggings or bearers to the two adjacent joists. Unless designed otherwise the noggings should not be less than 38 x 90mm at 600mm centres and fixed with metal clips. The sole plate of the non-loadbearing partition should be fixed to the noggings.

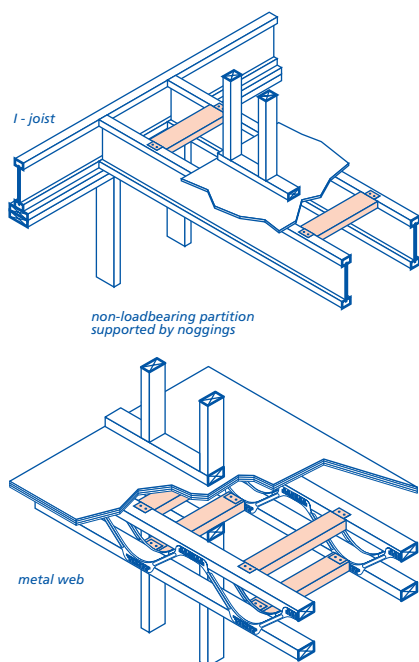

## (e) support of masonry partitions

Where first floor masonry partitions cannot be built overground floor masonry walls, steel or reinforced concrete beams should be specified to support the partition to avoid the effects of shrinkage and long term deflection which can occur with timber beams. It is not acceptable to support masonry partitions on joists unless they are designed by an Engineer in accordance with Technical Requirement R5.

## (f) heavy loads

Bearers or additional joists should be specified under heavy loads. Where I-joists and metal web joists are used refer to the manufacturer's detail.

## (g) adverse effects of shrinkage and moisture

Timber adjacent to heat sources, such as flues, boilers and hot water cylinders, is more susceptible to drying shrinkage. Structural softwood for internal use should be dry graded to BS 4978 (incorporating BS EN 518) or BS EN 519 and marked 'DRY' or 'KD'.

## TRIMMER JOISTS

### 6.4 - D5 Adequately sized trimmer joists shall be provided around floor openings

Trimmed openings may be needed around staircase openings and chimneys. Solid trimmed joists may be supported using either:

- joist hangers
- notches
- support battens (light loading only)
- tusked tenon joints.

I-joists and metal web trimmed joists may be supported using joist hangers. If an I-joist is used as a trimmer to support another I-joist, backer blocks should be provided on both sides of the web of the trimmer.

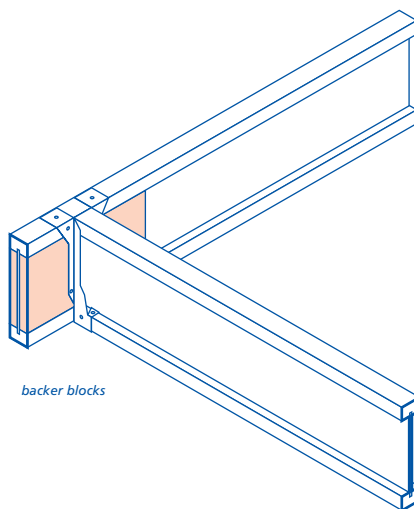

If a metal web joist is used as a trimming joist to support another metal web joist, timber uprights should be provided between the flanges of the trimmer.

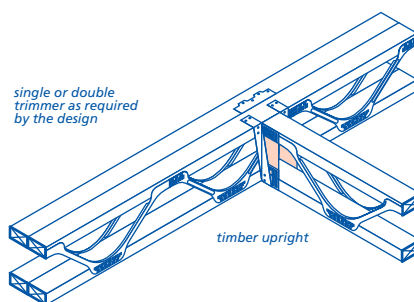

Trimmed openings should be designed in accordance with Technical Requirement R5 or other authoritative guidance.

Further information concerning staircases is given in Chapter 6.6 'Staircases' (Design and Sitework).

## STRUTTING OF FLOOR JOISTS

### 6.4 - D6 Strutting shall be adequate to distribute loads and limit movement within floors.

Herringbone strutting or blocking should be provided at the ends of solid joists where they:

- bear onto steelwork
- bear onto intermediate walls
- are supported on joist hangers.

Where solid joists span over 2.5m additional strutting should also be specified as follows:

Joist span [m]	Rows of strutting
Under 2.5	none needed
2.5 to 4.5	1 (at centre of span)
Over 4.5	2 (at equal spacing)

Herringbone strutting should be used whenever possible as blocking can be affected by shrinkage of both blocking and joists.

Metal strutting systems are also acceptable for solid joists if assessed in accordance with Technical Requirement R3.

Where required, strutting for I-joists should be provided in accordance with the table above.

Where required, strutting for metal web joists should be in accordance with the following table;

Joist span [m]	Rows of bracing
4.0 to 8.0	1 (at centre of span)
Over 8.0	2 (at equal spacing)

For metal web joists, bracing (strongbacks) should be provided.

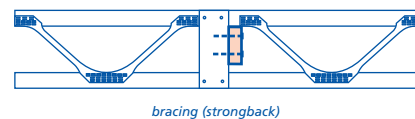

## JOIST HANGERS

### 6.4 - D7 Joist hangers shall be suitable for the joist type, width and depth, the strength of masonry and the required load

For solid timber joists the hanger should be the full depth of the joists.

For I-joists:

- the hanger should be the full depth of the joists and restrain the top flange, or
- be at least 0.6 x the depth of the joist and full depth stiffeners should be fixed to both sides of the web.

For metal web joists:

- the hanger should be the full depth of the joist and restrain the top flange or,
- top flange restraint should be provided (see Sitework clause 6.4-S4).

A timber upright should be fixed between the flanges of metal web joists.

Joist hangers should meet with the requirements of BS EN 845-1 or be assessed in accordance with Technical Requirement R3. The manufacturers of I-joists and metal web joists should be consulted about joist hangers suitable for their range of products.

If low strength masonry is used, the loading on the top flange of the joist hanger should not be greater than the strength of the supporting masonry.

### 6.4 - D8 Adequate end bearings shall be provided for joists and joist hangers

The design should detail the type of support to be used for joists, trimmers and trimming joists.

The minimum bearing for joists on hangers should be as follows:

Type of timber joist	Minimum bearing [mm]
Solid joist	75
I-joist	45
Metal web joist	75

The minimum bearing for hangers on masonry should be 75mm.

## JOIST SUPPORT AT SEPARATING WALLS

### 6.4 - D9 Joists shall be correctly supported at masonry separating walls

Joists built into separating walls may provide lateral support but it can conflict with sound insulation and fire resistance requirements in England & Wales.

In Scotland joists should not be built into separating walls.

## RESTRAINT STRAPS

### 6.4 - D10 Adequate restraint strapping shall be provided

Restraint straps and/or joist hangers suitable for taking tensile forces may be required to tie the walls and upper floors together. Restraint straps at not more than 2m centres should be provided along the walls that run parallel to the joists.

BS 8103-1 gives details of the connections between structural elements.

The position and size of restraint straps should be shown on drawings.

Where joists are supported on hangers restraint straps along the direction of the joists at not more than 2m centres are

required. In buildings of not more than two storeys where restraint type joist hangers, assessed in accordance with Technical Requirement R3 are used or where joists are built into a wall and bear at least 90mm on the wall no restraint straps are required along the joists.

## STRUCTURAL STEELWORK IN FLOORS

### 6.4 - D11 Steelwork in floors shall be designed by an Engineer

Structural steelwork should be in accordance with Chapter 6.5 'Steelwork support to upper floors and partitions' (each section), or should be designed by an Engineer in accordance with Technical Requirement R5.

Where steelwork supports solid timber joists, the depth of the timber joists should be such that they can be notched and have 12mm/2mm projections to allow for shrinkage of the timber.

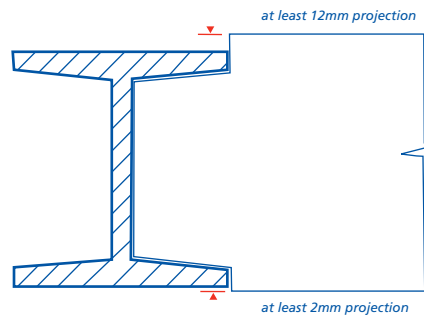

Structural continuity of the floor should be provided by the use of continuous decking fixed to joists on both sides of a transverse steel joist.

Steel sizes should allow adequate bearing for timber joists, where required.

Where steelwork supports I-joists, the joists may bear directly into the steel beam if there is at least 45mm bearing on the bottom flange of the steel beam. Noggings (38mm x thickness of flange) should be provided at the top and bottom flanges of the I-joists. If the bearing is less than 45mm timber blocking should be fixed to the steel beam to enable the I-joists to be face fixed using joist hangers to the blocking inside the steel beam.

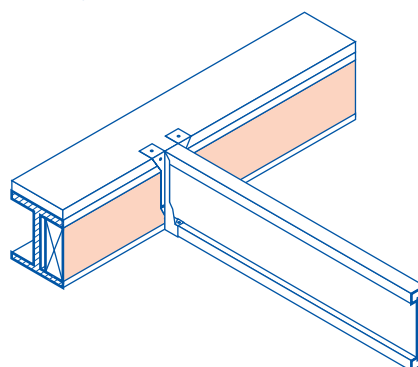

Flanges of metal web joists should not be notched. Joists can bear directly into the steel beam if there is at least 75mm bearing on the bottom flange of the steel beam. Timber uprights should be provided between the flanges and 38mm x 97mm noggings should be provided between the uprights. If the bearing is less than 75mm metal web joists can be supported on their top flange and their bottom flange should be fixed to timber blocking supported on the inside of the steel beam.

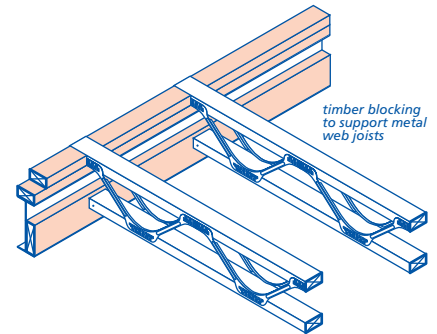

## FIRE SPREAD

### 6.4 - D12 Floors shall be designed to provide the appropriate fire resistance

All floors should have the fire resistance required by the relevant Building Regulations.

I-joists and metal web joists may require a different specification for the ceiling than that for solid timber joists to achieve the same fire resistance.

Ceilings should not be perforated (e.g. for downlighters) unless it can be shown that the floor construction achieves the required fire resistance.

### 6.4 - D13 Structural timber shall be located away from heat sources

Combustible material should be kept away from heat sources as described in Chapter 6.8 'Fireplaces, chimneys and flues' (Design and Sitework). In particular, structural timber should be at least 40mm from the outer surface of a masonry chimney or fireplace recess. Floorboards may be closer than 40mm from the chimney wall.

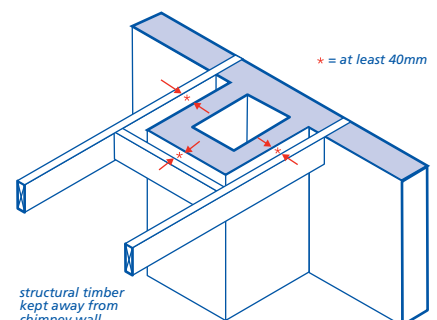

# 6.4 Timber and concrete upper floors

## FLOOR DECKING

### 6.4 - D14 Floor decking shall be suitable for the intended use

Items to be taken into account include:

#### (a) decking and joist centres

The correct thickness of decking should be specified for the joist centres used. Thicknesses should be not less than those shown in this table for normal domestic loads, i.e. an imposed load of 1.5kN/m<sup>2</sup>.

	Thickness of decking [mm]		
	Joist centres		
	400mm	450mm	600mm
T and G softwood boarding	16	16	19
Chipboard	18	18	22
Plywood	15	15	18
Oriented strand board	15	15	18/19

#### Note

Oriented strand board should be laid with the stronger axis at right angles to the supports. Other decking materials not listed in the table should comply with Technical Requirement R3. The above thicknesses may not be adequate to achieve a mass for floor decking of 15 kg/m<sup>2</sup> for sound insulation requirements of floors in England & Wales.

#### (b) resistance to moisture

Chipboard for flooring should be moisture-resistant flooring Type P5 to BS EN 312 throughout the dwelling. Oriented strand board should be Type OSB3 to BS EN300.

#### (c) fixing

Adequate support and correct fixings should be specified in accordance with the manufacturer's recommendations. All butt joints should be supported by joists or noggings. Nail length should be 2½ times the thickness of the decking material.

Some decking materials require their joints to be glued together and glued to joists (see Sitework clauses 6.4 - S19 and S20).

#### (d) sound insulation

Where the floor decking contributes to the sound insulation of a floor within a dwelling, the thickness of the decking given in (a) above may not achieve a mass of 15 kg/m<sup>2</sup>. Alternatively the floor construction may have been tested to show adequacy.

## CONCRETE FLOORS

### 6.4 - D15 Concrete floors shall be designed to transmit loads to the supporting structure without undue movement

Design should be in accordance with Clause D3.

Design of in-situ or precast concrete floors should be in accordance with BS EN 1992-1-1 and Technical Requirement R5. Proprietary concrete elements will be acceptable, if assessed in accordance with Technical Requirement R3.

## FLOORS IN AND BETWEEN DWELLINGS

### 6.4 - D16 Floors between dwellings shall be designed to provide adequate fire resistance

Materials and constructions should comply with Technical Requirement R3 and statutory requirements.

### 6.4 - D17 Floors between dwellings and where appropriate floors within dwellings shall be designed to adequately limit sound transmission

Materials and constructions should comply with Technical Requirement R3 and with statutory requirements.

## PROVISION OF INFORMATION

### 6.4 - D18 Designs and specifications shall be produced in a clearly understandable format and include all relevant information

The design should ensure compatibility with other drawings, especially with respect to services.

For upper floors, the drawings should show:

- direction of floor span and size and spacing of joists or concrete components
- size of trimmers and trimming joists
- position of strutting
- openings in the floor
- supporting walls below
- walls and partitions above
- positions of restraint straps
- positions of large service penetrations, eg chimneys, SVPs
- position of insulation
- details at all junctions.

### 6.4 - D19 All relevant information shall be distributed to appropriate personnel

Ensure that design and specification information is issued to site supervisors and relevant specialist subcontractors and/or suppliers.

Where proprietary components are to be used, manufacturers may have specific requirements for fixing and/or assembly of their products. This information should also be made available for reference on site so that work can be carried out satisfactorily, in accordance with the design and specification.

## MATERIALS STANDARDS

### 6.4 - M1 All materials shall: (a) meet the Technical Requirements (b) take account of the design

Materials that comply with the design and the guidance below will be acceptable for timber and concrete upperfloors.

Materials for timber and concrete upper floors should comply with all relevant standards, including those listed below. Where no standard exists, Technical Requirement R3 applies (see Chapter 1.1 'Introduction to the Standards and Technical Requirements').

References to British Standards and Codes of Practice include those made under the Construction Products Directive (89/106/EEC) and, in particular, appropriate European Technical Specifications approved by a European Committee for Standardisation (CEN).

## TIMBER FLOORS

### 6.4 - M2 Structural timber shall be of the appropriate grades and sizes to support the imposed loads

Structural timber should be specified according to the strength classes in BS EN 338. It is insufficient to specify timber using the BS 4978 (incorporating the requirements of BS EN 518) grading rules (eg GS or SS) unless the timber species is also specified so that the strength class can be determined.

Finger joints should comply with BS EN 385.

Where possible, regularised timber should be used for joists.

I-joists and metal web joists should be assessed in accordance with Technical Requirement R3.

### 6.4 - M3 Structural timber shall be of suitable durability, particularly in conditions where it could become damp

Timber that is built into solid external walls or embedded should be pre-treated with preservative. Reference should be made to Chapter 2.3 'Timber preservation (natural solid timber)' (each section) for recommended methods of preservative treatment.

Any timber treated with preservative and cut after treatment should be given two liberal applications of a suitable colour tinted preservative to the cut surfaces.

### 6.4 - M4 Structural timber shall have a suitable moisture content

Structural softwood for internal use should be dry graded to BS 4978 or BS EN 519 and marked 'DRY' or 'KD'.



## JOIST HANGERS AND RESTRAINT STRAPS

**6.4 - M5 Hangers and straps shall be of appropriate types and strength and shall have adequate durability**

Joist hangers to BS EN 845-1 are acceptable. It is important that joist hangers are the correct size for the timber joist or trimmer.

Where joist hangers are required to resist tensile forces, they should comply with the requirements of BS EN 845-1 with performance equivalent to restraint straps at 2m centres or proprietary joist hangers that have been assessed in accordance with Technical Requirement R3.

Restraint straps should have a cross-section of at least 5 x 30mm or be proprietary restraint straps assessed in accordance with Technical Requirement R3 and be protected in accordance with the requirements of BS 845-1. Appendix 6.1-F lists suitable materials and protective finishes. The size of nails or screws should be specified for fixing restraint straps to joists.

## STRUTTING

**6.4 - M6 Strutting shall ensure adequate rigidity of the floor structure**

Timber strutting should be either:

- herringbone strutting at least 38mm x 38mm, or
- solid strutting at least 38mm thick and at least three-quarters the depth of the joist.

Proprietary metal strutting should have been assessed in accordance with Technical Requirement R3.

Thin metal strip is not acceptable as strutting.

## FLOOR DECKING

**6.4 - M7 The type and thickness of the decking material shall have adequate strength and moisture resistance**

The following materials are acceptable:

- softwood boarding in accordance with BS 1297
- moisture-resistant chipboard, Type P5 to BSEN 312. Ring shank nails (length  $2\frac{1}{2}$  x decking thickness) or screws should be specified for fixing chipboard
- oriented strand board Type OSB3 to BS EN 300
- plywood in accordance with BS EN 636. Fixings and support should be as recommended by the manufacturer
- floor decking materials not covered by a British Standard should have been assessed in accordance with Technical Requirement R3.

Some decking materials require their joints to be glued together and glued to joists (see Sitework clauses 6.4 - S19 and S20).

## SOUND INSULATION

**6.4 - M8 Materials and systems for floating floors, including insulation materials, shall be of a type that will provide adequate sound insulation**

Details of materials and systems for floating floors should be in accordance with Chapter 8.3 'Floor finishes' (each section).

Materials and systems should comply with relevant Building Regulations.

## STRUCTURAL STEELWORK IN FLOORS

**6.4 - M9 Steelwork shall be suitably durable and be of the appropriate section to support the imposed loads**

Structural steel should be in accordance with Chapter 6.5 'Steelwork support to upper floors and partitions' (each section), or be designed by an Engineer in accordance with Technical Requirement R5.

Steel beams should be protected by a suitably durable paint coating as detailed in Chapter 8.5 'Painting and decorating' (each section). Intumescent paints should be compatible with paints providing corrosion protection.

## CONCRETE AND REINFORCEMENT

**6.4 - M10 Concrete shall have appropriate reinforcement and be of a mix design that is suitable for the location and intended use**

For guidance on the specification and use of concrete, concrete additives and reinforcement, reference should be made to Chapter 2.1 'Concrete and its reinforcement' (each section).

## PROPRIETARY SYSTEMS

**6.4 - M11 Proprietary concrete flooring systems shall have adequate strength and durability**

Proprietary concrete flooring systems should be designed in accordance with BS EN 1992-1-1, or should have been assessed in accordance with Technical Requirement R3.

## SITWORK STANDARDS

**6.4 - S1 All sitework shall:**  
**(a) meet the Technical Requirements**  
**(b) take account of the design**  
**(c) follow established good practice and workmanship**

Sitework that complies with the design and the guidance below will be acceptable for timber and concrete upper floors.

## TIMBER FLOORS

**6.4 - S2 Solid timber, I-joists and metal web joists shall be selected, located and supported as detailed in the design**

Items to be taken into account include:

**(a) grades and sizes**  
 Check materials on delivery to site for conformity with the drawings and specification.

Structural timber should be marked to show its strength class (normally C16 or C24). Alternatively, evidence of species and grade should be available to determine the equivalent strength class.

Where timber is graded to BS 4978 or BS EN 519, it should also be marked with identification of the company responsible for the grading.

Storage time may be minimised by phasing deliveries to suit the work programme. When storage is required, timber should be stored on bearers or in racks and be protected.

store timber off ground on bearers

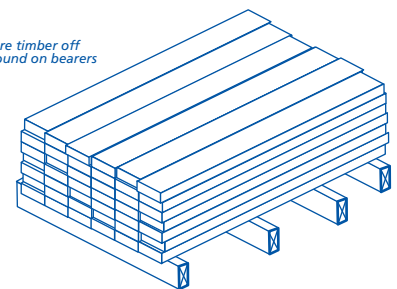

I-joists and metal web joists should be protected from adverse weather conditions during transport and storage. They should be stored clear of the ground and stacked vertically. Manufacturers' recommendations for handling, transport and storage should be followed. Damaged joists should not be used.

**(b) moisture content**  
 Structural softwood for internal use should be dry graded to BS 4978 or BS EN 519 and marked 'DRY' or 'KD'.

# 6.4 Timber and concrete upper floors

## (c) quality

Timber should not be used if it:

- is excessively bowed, twisted or cambered
- has large edge knots or shakes
- has a wavy edge more than half the thickness
- has any sign of rot
- has been damaged.

## (d) bearing

Bearings for joists should be as follows;

Type of timber joist	Minimum bearing [mm]	
	End support	Intermediate support
Solid joist on masonry walls	90 (75)	90 (75)
Solid joist on timber wall plate	75	75
I-joist	90 (45)	90
Metal web joist	90 (75)	90

## Note

Figures in brackets should only be used when the joist is not providing restraint to the wall.

Bearings should be level. If joists are not laid level, the floor will be springy and uneven. Where bearings are uneven, joists should be levelled using hard packing, eg tiles or slates bedded in mortar. Loose or soft packing should not be used.

For further information concerning timber framed construction, reference should be made to Chapter 6.2 'External timber framed walls'.

## (e) levelling

Where possible, regularised timber should be used.

The floor should be levelled from the staircase trimmer and trimming joist.

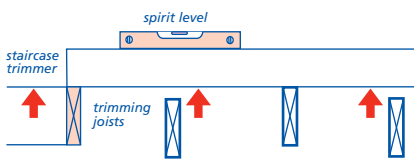

joists levelled from staircase trimmer or trimming joist

## (f) joist spacings

Joist spacing should be as shown on the drawings. If the joist spacing is not shown, the designer should provide spacing details. Do not increase the spacing. Joists should not be spaced at more than 600mm centres. The decking material to be used should be taken into account.

## (g) clearance from the wall

When placing joists, a clearance of 25mm to 75mm should be allowed between the first joist and the wall face. This helps when installing services and fixing floor decking.

## JOIST HANGERS

### 6.4 - S3 Hangers shall be of the correct size and properly built in

It is important that the joist hanger is the correct size for the joist or trimmer.

For solid timber joists and metal web joists the hanger should be the full depth of the joists. A timber upright should be fixed between the flanges of metal web joists.

For I-joists the depth of the hanger should be at least 0.6 x the depth of the joist. Full depth stiffeners should be fixed to both sides of the web if the hanger does not restrain the top flange of an I-joist.

Where joist hangers are supported on lightweight blockwork, the suitability of the hanger should be checked. Joist hangers which meet BS EN 845 are stamped on the base or gusset with the minimum compressive strength of block for which they are suitable, eg 2.9N/mm<sup>2</sup> or 3.6N/mm<sup>2</sup>. Where hangers are to BS EN 845-1 ensure the supporting masonry is that specified in the design.

Joist hangers should be supported on level beds and should be tight to the wall.

The masonry course to carry the joist hangers should be checked for level and height. Hangers should not be cut into the walling.

Where restraint type joist hangers are shown in the design do not use alternatives without checking with the designer.

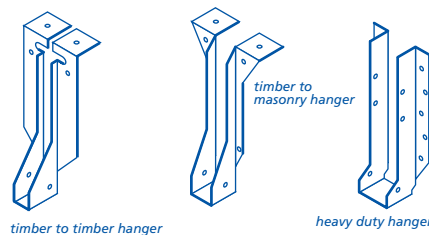

### 6.4 - S4 Joists shall be properly cut to length and fitted to joist hangers

Joists should be accurately cut to length for a tight fit. Solid joists should be notched into the hanger to keep the ceiling line level.

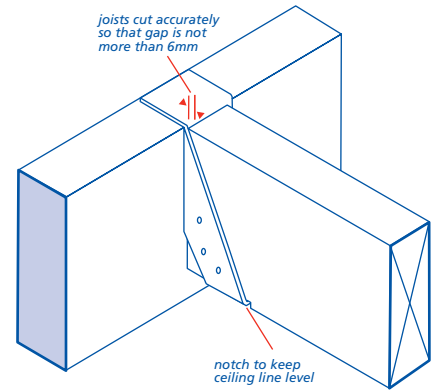

Flanges of I-joists should not be notched. Tabs of the hanger should be bent and nailed to the bottom flange of the I-joist.

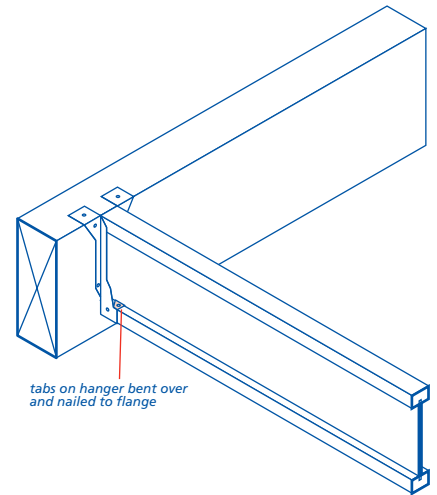

Flanges of metal web joists should not be notched. When used with hangers the top flange of metal web joists should be restrained.

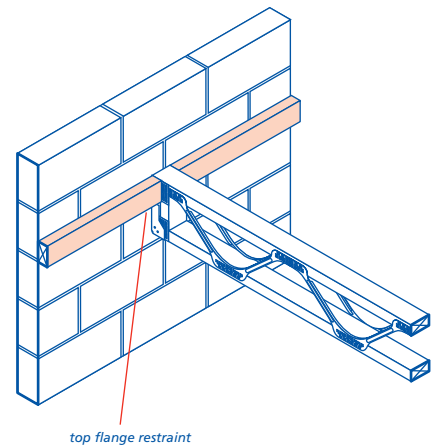

All circular holes in the vertical sides of joist hangers should be fully nailed.

When joist hangers are used at both ends of a joist, measuring, marking and cutting should be accurate to ensure the joist fits properly at both ends.

## TRIMMED AND TRIMMING JOISTS

### 6.4 - S5 Trimmed and trimming joists shall be properly supported

Trimmed and trimming joists should be used as detailed in the design.

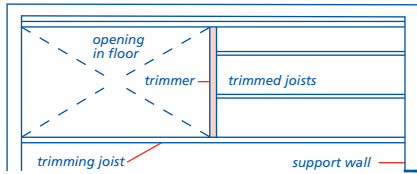

The thickness and depth of trimmed and trimming joists should be as detailed in the design.

The ends of trimmed solid joists may be supported using joist hangers or notches. When using hangers, 'timber-to-timber' hangers should be used, not wall hangers.

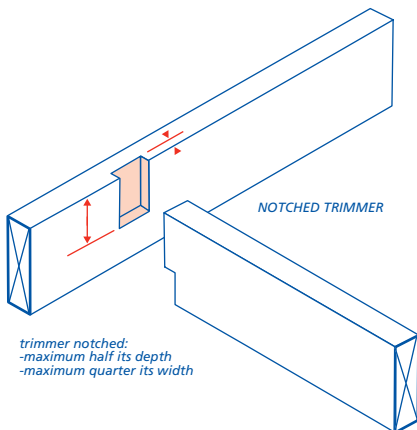
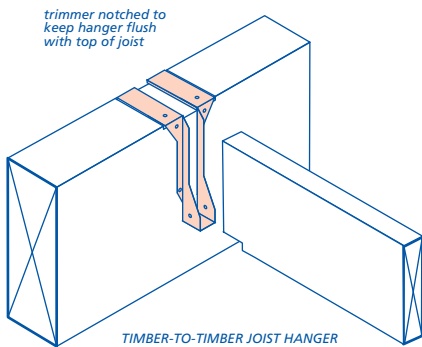

For lightly loaded trimmed joists, support battens (plates) may be used.

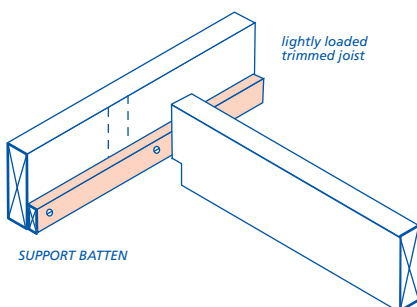

Flanges of I-joists should not be notched and should be supported on trimmers by 'timber-to-timber' hangers. Timber blocking should be used to face fix a joist to a trimmer joist.

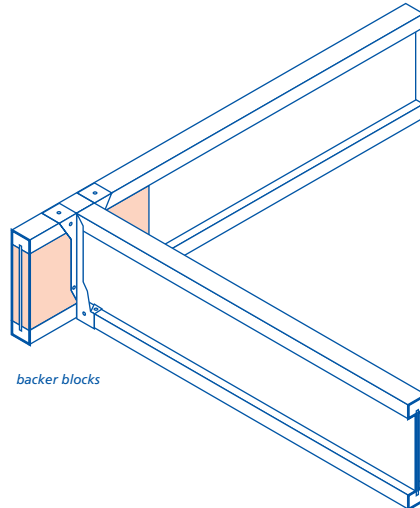

Flanges of metal web joists should not be notched and 'timber-to-timber' hangers should be used to join a joist to a trimmer joist.

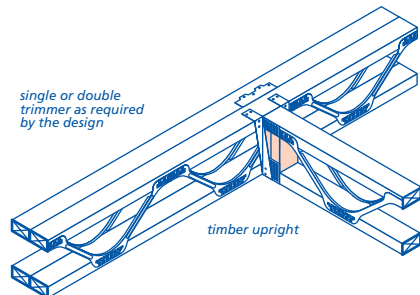

### 6.4 - S6 Joists shall be properly trimmed into steelwork

Joists trimmed into steelwork should be notched at both top and bottom and have 12mm/2mm projections respectively to allow for timber shrinkage.

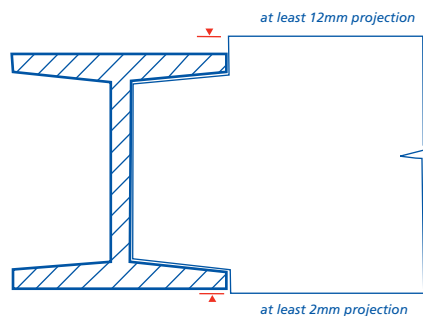

Flanges of I-joists should not be notched. I-joists can bear directly into the steel beam if there is at least 45mm bearing on the bottom flange of the steel beam and noggings (38mm x thickness of flange) should be provided at the top and bottom flanges of the I-joists. If the bearing is less than 45mm timber blocking should

be fixed to the steel beam to enable the I-joists to be face fixed using joist hangers to the blocking inside the steel beam.

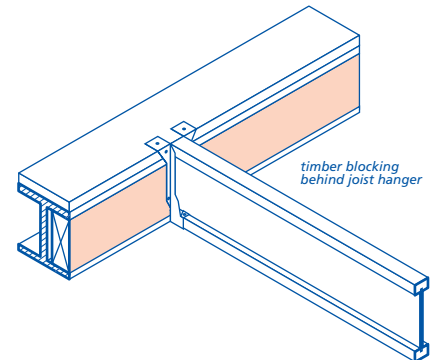

Flanges of metal web joists should not be notched. Joists can bear directly into the steel beam if there is at least 75mm bearing on the bottom flange of the steel beam. Timber uprights should be provided between the flanges and 38mm x 97mm noggings should be provided between the uprights. If the bearing is less than 75mm metal web joists can be supported on their top flange and their bottom flange should be fixed to timber blocking supported inside the steel beam.

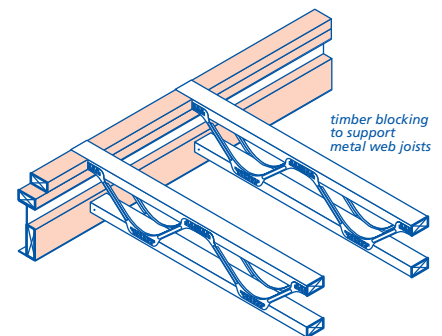

## MULTIPLE JOISTS

### 6.4 - S7 Multiple joists shall be securely fixed together

Solid timber joists may be doubled up to support a non-masonry partition or to form trimmers.

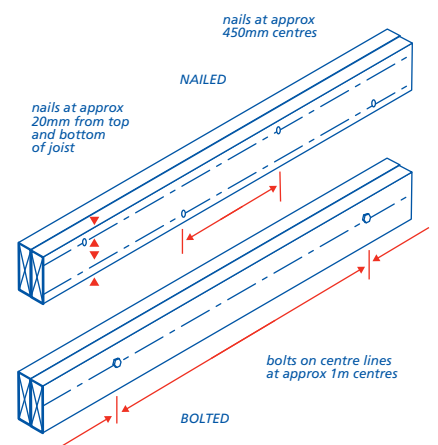



# 6.4 Timber and concrete upper floors

Fixings should be to the Engineer's specification and should be given a second check for tightness just before fixing the ceiling.

Toothed plate, split ring and shear plate connectors should be used in strict accordance with manufacturers' recommendations.

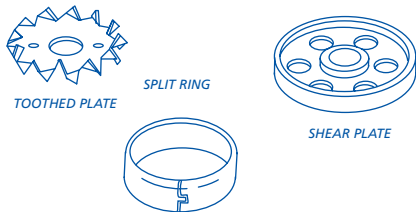

Washers, or single faced connectors, should be used with bolts. Check whether toothed connectors are required between the timber faces. Ensure that all washers, etc are provided.

Bolts should be checked for tightness (fixing bolts should not be used for tightening). Make sure that timber is not damaged by over-tightening.

I-joists can be doubled or tripled up in accordance with manufacturer's recommendations to support a lightweight partition or to form trimmers. The design should specify how the joists are fixed together.

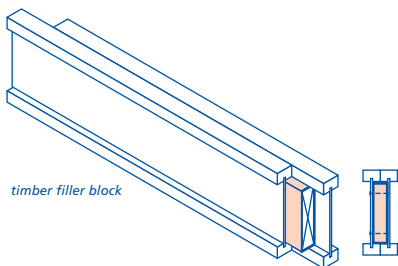

## STRUTTING OF FLOOR JOISTS

### 6.4 - S8 Appropriate strutting shall be provided to joists, where required

Items to be taken into account include:

#### (a) span of the floor

Strutting for solid timber joists should be provided before laying floor decking as follows:

Joist span [m]	Rows of strutting
Up to 2.5	none needed
2.5 to 4.5	1 (at centre of span)
Over 4.5	2 (at equal spacing)

For solid timber joists either herringbone strutting (38mm x 38mm timber) or minimum 38mm thick solid strutting should be used, for not less than three-quarters the depth of the joist. Strutting

should not project beyond the top and bottom edges of joists.

At the end of each run of strutting the last joist should be firmly blocked to the wall.

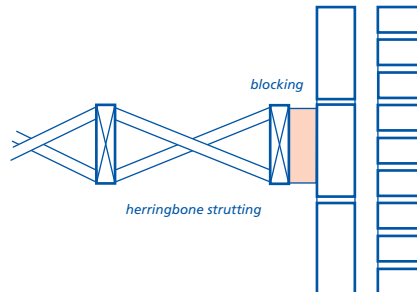

Where I-joists require strutting it should be provided in accordance with the table for solid timber joists.

Where metal web joists require strutting it should be in accordance with the following table:

Joist span [m]	Rows of bracing
4.0 to 8.0	1 (at centre of span)
Over 8.0	2 (at equal spacing)

For metal web joists, bracing (strongbacks) should be provided.

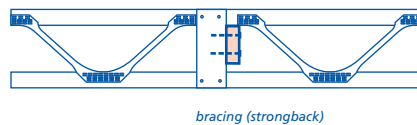

#### (b) bearings onto steelwork

Strutting should be provided where solid timber joists bear on, or are notched into, steelwork to prevent rotation.

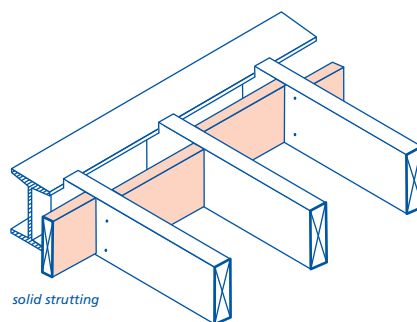

Strutting should be provided where I-joists bear directly onto the bottom flange of the steel beam. Noggings (38mm x thickness of flange) should be provided at the top and bottom flanges of the I-joists. Strutting is not necessary when an infill timber blocking is fixed to the steel beam and joists hangers of full depth of the joists are used to face fix the joists to the blocking.

Strutting should be provided where metal web joists bear directly on to the bottom flange of the steel beam. Timber uprights should be provided between the flanges and 38mm x 97mm noggings should be provided between the uprights.

#### (c) joists supported by hangers

Solid blocking should be used at all joist bearings of solid timber joists where they are not built into brickwork or blockwork. This includes some forms of timber frame construction. The blocking may be used for fixing plasterboard and floor decking.

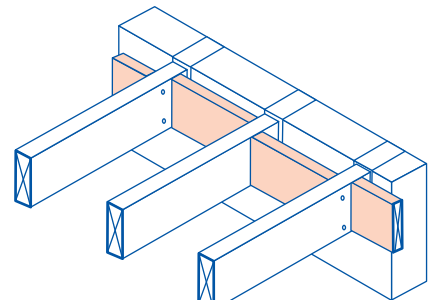

solid blocking where joists are not built into blockwork

#### (d) I-joists and metal web joists supported on walls

Noggings should be provided for I-joists and metal web joists at the top flange along the wall to support the floor decking. Noggings at the bottom flange may be required to support the plasterboard ceiling.

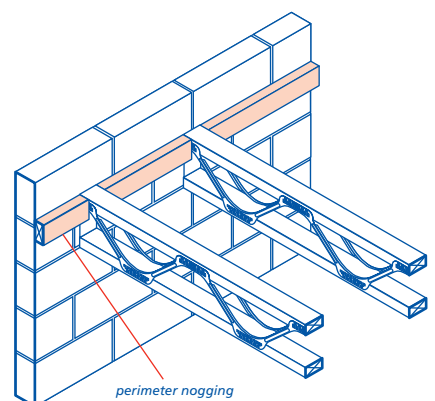
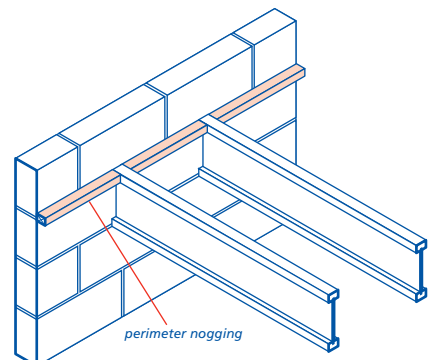

## NOTCHING AND DRILLING

### 6.4 - S9 Notching and drilling shall be carried out within recognised limits

Items to be taken into account include:

#### (a) solid timber joists

Solid timber joists and studs should only be notched and drilled within the limits shown in the table below:

Item	Location	Maximum size
Notching joists up to 250mm depth	Top edge 0.1 to 0.2 of span	0.15 x depth of joist
Drilling joists up to 250mm	Centre line 0.25 to 0.4 of span	0.25 x depth of joist

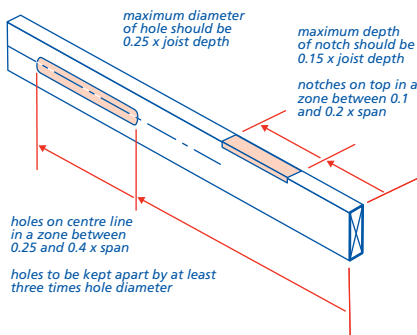

Notches and drillings in the same joist should be at least 100mm apart horizontally.

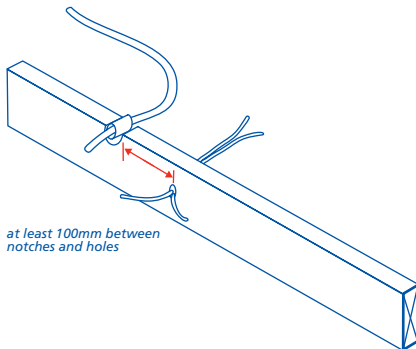

Special instructions should be obtained from the designer when notching and drilling:

- is required in joists deeper than 250mm
- does not meet the above guidelines, or
- is needed close to heavy loads, such as those from partitions, cisterns, cylinders and stair trimming.

If structural strength is impaired by notching or drilling, the element should be replaced or correctly repaired.

#### (b) I-joists

In I-joists pre-formed holes are provided in the timber webs for pipes and cables. Other holes or notches should not be cut without the approval of the manufacturer. However, restraint straps can be slotted into webs immediately below the top flange.

#### (c) metal web joists

In metal web joists service conduits should run in the gaps between the metal webs. The maximum duct sizes should be in accordance with the manufacturer's recommendations. Large service ducts may have to be inserted before fixing the joists as it may not be possible after the joists have been fixed.

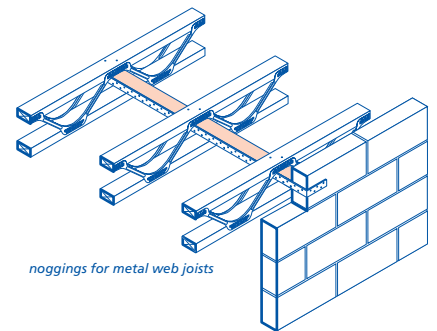
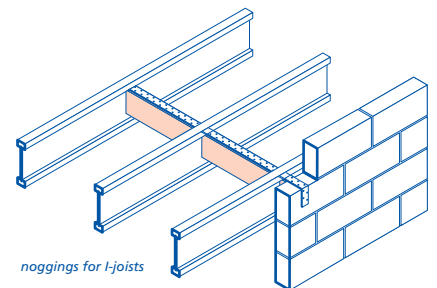
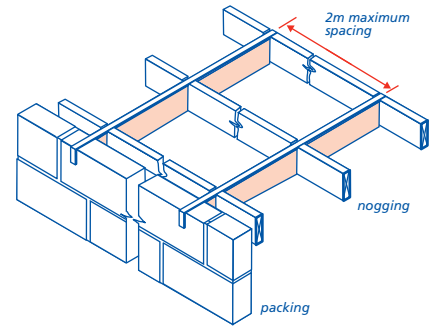
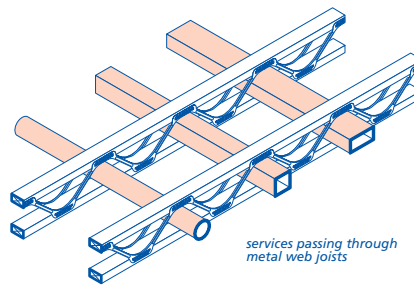

## RESTRAINT STRAPPING

### 6.4 - S10 Restraint strapping shall be provided where specified in the design details

When the external wall is to be stabilised by connection to the floor, straps may be required. They may be fixed to the top or bottom of the joist, depending on how the masonry is coursed.

Straps should have a cross section of 30mm x 5mm galvanised steel straps or straps which have been assessed in accordance with Technical Requirement R3. (See clause 6.4 -S12 for fixing details).

Where joists run parallel to the wall, straps should be supported on noggings fixed between the three joists adjacent to the wall.

Solid timber joists should have noggings not less than 0.5 times the depth of the joists if the strap is located on top of the joists but the full depth if located beneath the joists.

I-joists should have solid timber noggings not less than 0.5 times the depth of the I-joists up to a maximum of 150mm, fixed between the webs and located beneath the top flange of the I-joists when 30mm x 5mm galvanised straps are used. Where straps which have been assessed in accordance with Technical Requirement R3 are used the noggings should be short lengths of I-joist or solid timber noggings to the full depth of the I-joists.

Metal web joists should have solid timber noggings, size 35mm x 97mm, used beneath the top flange of the metal web joists and twice nailed to the joists.

Straps should be placed at a maximum of 2m apart and carried over the three joists. Packing should be provided between the wall and the first joist.

In buildings of not more than two storeys where joists are supported on walls, restraint straps will not normally be required at the ends of joists, if there is at least 90mm bearing (eg if they are built into masonry).

Separate straps should be fitted along the joists and at centres not more than 2m unless the joist hangers are designed to provide restraint.

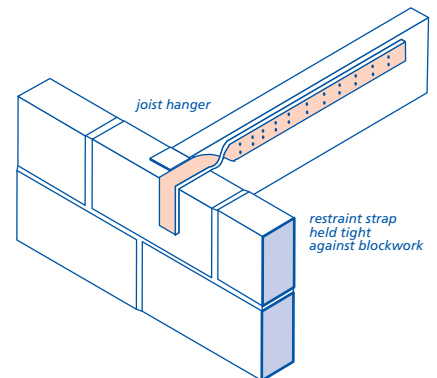

# 6.4 Timber and concrete upper floors

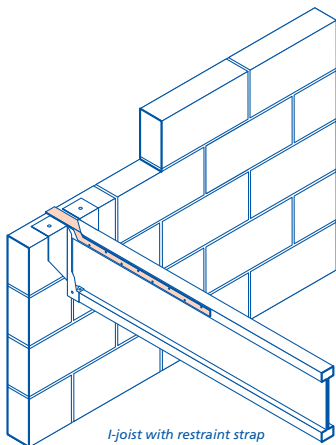

I-joist with restraint strap

## 6.4 - S11 Straps shall be located to provide adequate restraint for the masonry

Straps should bear on the centre of bricks or blocks, not on mortar joints.

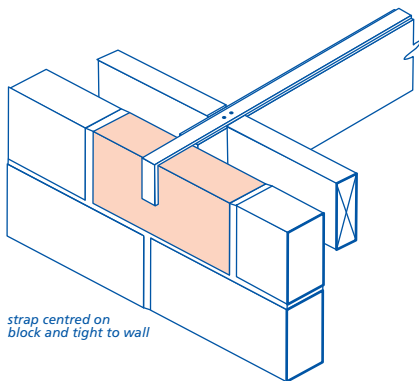

strap centred on block and tight to wall

## 6.4 - S12 Straps shall be fixed with suitable screws or nails

Straps may be fixed on the side, top or bottom as appropriate for all joist types. I-joists and metal web joists should not be notched.

Straps to walls which run parallel to the joists should extend over at least three joists. They should be fixed with 2 screws or nails into each joist. The fixings should be 3.75mm x 30mm square twisted nails for all joist types. Noggings should be provided to receive two additional nails. Alternatively for solid joists two 4.76mm diameter x 50mm long wood screws (No. 10) or 4mm diameter x 75mm round nails (8 SWG) can be used in each joist.

When nailing into Laminated Veneer Lumber flanges of I-joists, care should be taken to prevent the splitting of the flanges. Nails should be driven in at an angle (not horizontally) and should not protrude from the flanges.

## OVERLAPPING AND BUTTED JOISTS

### 6.4 - S13 Joists shall be properly fixed at intermediate load bearing walls

Items to be taken into account include:

#### (a) solid timber joists

Where joists overlap on load bearing intermediate walls, they should be nailed together and cut so that they will not project beyond the supporting wall by more than 100mm. This is to prevent the floor decking being pushed up or the ceiling being cracked when the cantilevered part of the joist moves upwards.

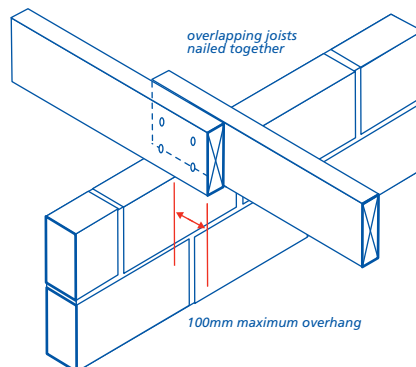

overlapping joists nailed together

100mm maximum overhang

#### (b) I-joists

Where I-joists are supported on load bearing intermediate walls they should be fixed as follows:

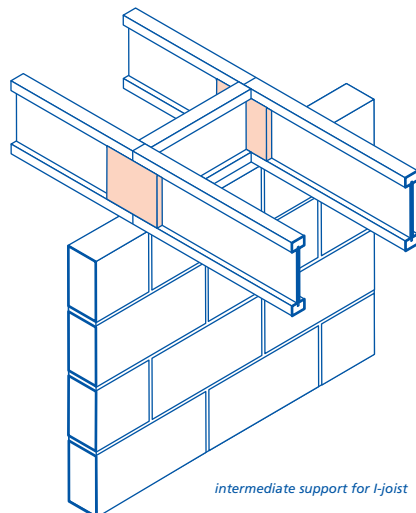

intermediate support for I-joist

#### (c) metal web joists

Where metal web joists are supported on load bearing intermediate walls they require a minimum bearing of not less than 90mm. Joists should be overlapped. Blocking is required between the joists unless walls are built up to the underside of the floor.

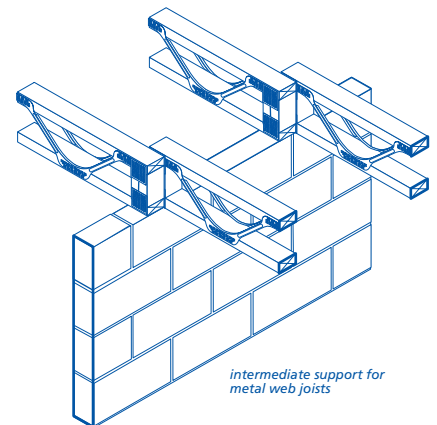

intermediate support for metal web joists

## FLOOR DECKING : GENERAL

### 6.4 - S14 Flooring shall only be fixed at the appropriate time during the construction process

Timber based materials can swell if they become wet and may twist and bow producing large gaps when drying out. If timber decking is installed before the dwelling is substantially watertight the manufacturer should confirm that it is suitable for that situation.

When floor decking has to be stored, it should be stored on a hard base, under cover, if possible indoors.

### 6.4 - S15 Floor decking shall be securely fixed to the floor joists

Before fixing floor decking, a check should be made that all noggings, blocking and strutting are in place and fixed securely.

The length of nails should be 2½ times the thickness of the decking.

The ends of adjacent boards should be square. Joints should be staggered and supported on noggings or joists. Reference should be made to Clause S23 for fixing floating floors.

Temporary wedges and packings at the perimeter should be removed after the floor decking is complete.

### 6.4 - S16 Completed floor decking shall not be overloaded and shall be protected against damage

Floors should not be overloaded, especially with materials stored during construction. Where necessary, fixed flooring and/or floor decking should be protected against damp (for example from plaster splashes) and damage.

## SOFTWOOD BOARDING

### 6.4 - S17 Softwood boarding shall be securely fixed

End (butt) joints should be made on joists and staggered, ie the joints of adjacent boards should not be on the same joist.

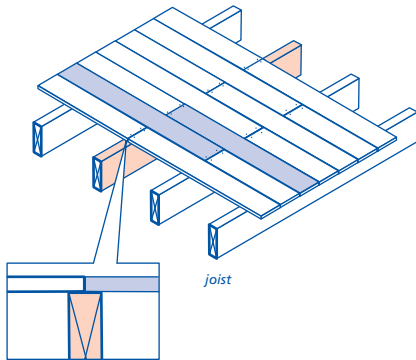

Board thickness should not be less than the following for the joist spacings indicated:

Board thickness [mm]	Maximum joist centres [mm]
16	450
19	600

Boards should be cramped up and either double nailed or secret nailed to each joist. Nails should be of a length 2½ times the thickness of the decking and should be punched well below the surface.

The above thicknesses may not be adequate to achieve a mass for floor boarding of 15 kg/m<sup>2</sup> for sound insulation requirements of floors in England & Wales.

## CHIPBOARD FLOORING

### 6.4 - S18 Chipboard flooring shall be of the type and thickness specified

Only moisture-resistant, Type P5 chipboard to BS EN 312 should be used for flooring. This can be recognised by the green stripe on the chipboard edge and an identifying marking.

Board thicknesses should be not less than the following for the joist spacings indicated:

Board thickness [mm]	Maximum joist centres [mm]
18/20	450
22	600

The above thicknesses may not be adequate to achieve a mass for floor decking of 15 kg/m<sup>2</sup> for sound insulation requirements of floors in England & Wales.

### 6.4 - S19 Chipboard flooring shall be securely fixed

#### ALL TYPES OF CHIPBOARD

Chipboard should be supported and fixed in accordance with manufacturers' instructions, using either:

- flat-headed ring shank nails minimum 3mm diameter and of length 2½ times the thickness of the chipboard, or
- screws, to BS 1210 with a minimum length of twice the board thickness and not less than size no. 8.

Edges at room perimeters should be supported on joists or noggings.

Fixings should be spaced at centres not more than 300mm apart along the continuously supported edges and the intermediate supports.

Expansion gaps should be not less than 10mm wide where boards abut a rigid upstand. For larger areas of boarded floor a wider gap may be needed at upstands and intermediate expansion gaps equal to 2mm per linear metre of floor provided.

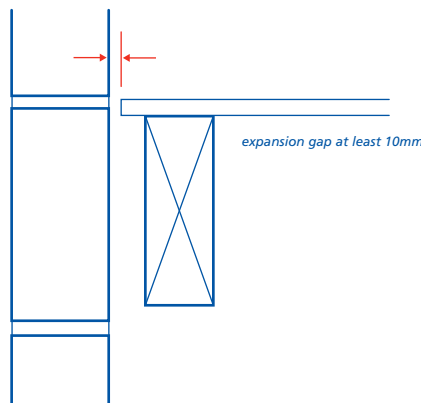

#### SQUARE EDGED BOARDS AND BOARDS WITH LOOSE TONGUES

Boards should be supported on all sides on joists or noggings.

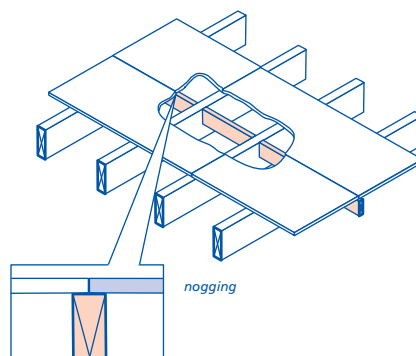

#### TONGUED AND GROOVED BOARDS

Boards should be laid with long edges at right angles to joists.

Short edges should be supported on joists or noggings.

Projecting ends of boards should be cut back to form a butt joint on a joist.

To reduce squeaking, tongued and grooved joints between boards should be glued and the boards should be glued to the joists. A suitable polyvinyl acetate (PVAC) adhesive should be used.

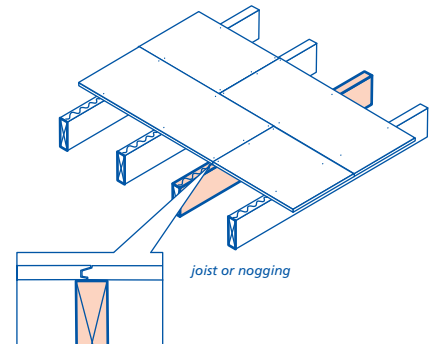

## ORIENTED STRAND BOARD FLOORING

### 6.4 - S20 Oriented strand board flooring shall be securely fixed

Oriented strand board should be laid over supports in the direction indicated on the boards. The stronger axis should be laid at right angles to the supporting joists.

All square edges should be supported. All short edges should be supported on the centre line of the joist. It is not necessary to support the long edges of tongued and grooved boards, except at room perimeters where all board edges should be fully supported.

No boards less than two joist spacings long should be used.

Nails should be flat headed, annular grooved nails 3mm in diameter.

Expansion gaps should be not less than 10mm wide where boards abut a rigid upstand. For larger areas of boarded floor a wider gap may be needed at upstands and intermediate expansion gaps equal to 2mm per linear metre of floor provided.

To reduce squeaking, tongued and grooved joints between boards should be glued and the boards should be glued to the joists. A suitable polyvinyl acetate (PVAC) adhesive should be used.

## PLYWOOD FLOORING

### 6.4 - S21 Plywood decking shall be securely fixed

Plywood should be laid with the face grain at right angles to the supports. All butt joints and joints with loose tongues should be supported on joists or noggings. All end joints should occur over joists (38mm minimum thickness) or noggings.



# 6.4 Timber and concrete upper floors

Board thickness should be not less than the following for the joist spacings indicated:

Board thickness [mm]	Maximum joist centres [mm]
12	450
16	600

The above thicknesses may not be adequate to achieve a mass for floor decking of 15 kg/m<sup>2</sup> for sound insulation requirements of floors in England & Wales.

Nails for fixing plywood should be either:

- plain wire nails - minimum diameter 3.35mm
  - minimum length 65mm
  - with penetration not less than 40mm, or
- annular-ring shank nails - minimum diameter 3mm
  - minimum length 50mm
  - penetration not less than 32mm.

Fixings should be at 150mm centres (max) around the perimeter and 300mm centres (max) on intermediate supports.

An expansion gap of at least 1.5 - 2mm should be allowed between each panel.

## OTHER FLOOR DECKING

### 6.4 - S22 Proprietary flooring materials shall be securely fixed

Proprietary floor decking should be assessed in accordance with Technical Requirement R3 and be fixed in accordance with any certification requirements.

## FLOORS BETWEEN DWELLINGS

### 6.4 - S23 The floating part of a floor shall be completely separated by a resilient layer from the main structure and surrounding walls

The structural component of floors between dwellings may be concrete, steel, timber or a combination of these materials.

The floor finish should be isolated from walls and skirtings.

Proprietary floating floor materials and systems should be fixed strictly in accordance with the manufacturer's and any relevant certification requirements and Building Regulations.

Where board materials are laid loose, all joints in tongued and grooved boards should be glued.

## CONCRETE FLOORS

### 6.4 - S24 Concrete upper floors shall be constructed/erected in accordance with the design.

Care should be taken to ensure that concrete floors are reasonably level and smooth. Particular care should be taken at doorways and junctions.

### 6.4 - S25 Appropriate measures shall be taken when concreting or screeding in cold weather

Reference should be made to Chapter 1.4 'Cold weatherworking'.

## IN-SITU CONCRETE

### 6.4 - S26 Reinforced concrete upper floors shall be constructed in accordance with design details

All concrete work should be in accordance with Chapter 2.1 'Concrete and its reinforcement' (each section).

The Builder should not depart from the design without the Engineer's written consent.

## PRECAST CONCRETE

### 6.4 - S27 Precast concrete upper floors shall be erected in accordance with design details

Items to be taken into account include:

#### (a) manufacturer's assembly instructions

A copy of the manufacturer's assembly instructions (and BBA Certificate, if applicable) should be on site and the recommendations should be followed.

The Builder should not depart from the design without the Engineer's written consent.

#### (b) bearings

Bearings onto masonry should be 90mm minimum. Bearings onto steelwork should be 75mm minimum.

Bearings should be solid and level. Any open frogs in brickwork should be filled.

#### (c) setting out of beams

When setting out beam and block floors, use the infill blocks as spacers to ensure correct spacing between beams.

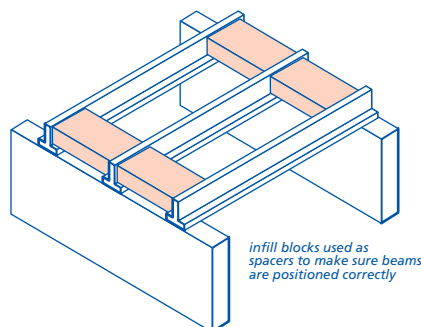

Beam layout drawings should always be followed. Doubled beams usually support concentrated loads, such as partitions.

#### (d) propping of beams and planks during construction

Where floors rely on structural topping or in-situ make-up sections, propping may be needed until the in-situ concrete has reached its design strength.

#### (e) grouting of joints

Most precast floors rely on a grout to ensure composite action of the units and provide adequate strength, as well as fire and sound resistance.

The manufacturer's specification should be checked for the grout mix.

#### (f) restraint straps and ties

Restraint straps should be shown on the drawings. They are usually necessary where the beams run parallel with the wall.

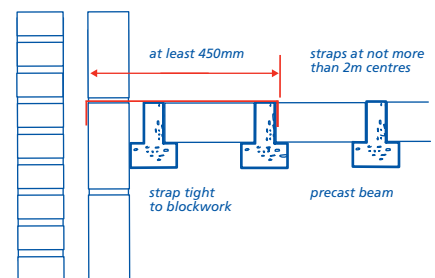

Metal ties may be required to provide a structural link across internal and separating walls.

#### (g) position of holes for services

Where holes are required for services, blocks should be omitted or cut where necessary. Infill blocks should be cut carefully and neatly without damage. Using a hammer and bolster to cut blocks may cause significant damage.

#### (h) trimmed openings

Large openings for staircases and chimneys may require openings to be trimmed. Specifications and drawings should be followed.

Steel trimmer shoes may be used to trim openings.

Doubled beams are common around trimmed openings, and should be propped until all voids have been solidly concreted and the concrete has reached its design strength.

#### (i) cracked or broken components

Beams, planks or infill blocks that are cracked should not be used.

**(j) clips for suspended ceiling**

Some designs include metal ceiling clips inserted between the planks or blocks so that timber battens can be fixed below.

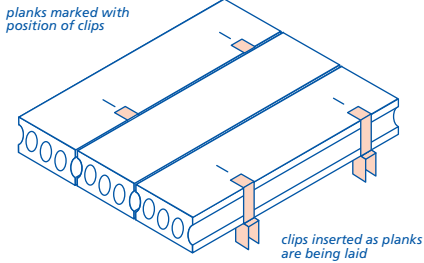

**FIRE-STOPPING**

**6.4 - S28 Penetrations in floors between dwellings shall be fire-stopped.**

The specified method of fire-stopping should be carried out. There should be no holes or gaps for smoke to penetrate once the fire-stopping has been installed. Where downlighters are incorporated in a ceiling they should be installed in accordance with the manufacturer's instructions

**APPENDIX 6.4-A**

**Span tables for solid timber floor joists**

Tables 1 and 2 in this Appendix are derived from the TRADA Technology Ltd. publication "Eurocode 5 span tables for solid timber members in floors, ceilings and roofs for dwellings (3rd edition)".

The section sizes of the floor joists given in Tables 1 and 2 should be regularised, or be ALS or CLS to enable floors and ceilings to be level.

For upper floors with a 22mm thick chipboard decking and 12.5mm plasterboard ceiling, a dead load of between 0.25kN/m<sup>2</sup> and 0.5kN/m<sup>2</sup> may be assumed. Use the centre three columns from the tables.

For timber floors between dwellings, the dead load of the construction to meet acoustic performance is likely to be within the range 0.6kN/m<sup>2</sup> to 0.7kN/m<sup>2</sup>, therefore use the three right-hand columns.

Floors based on these tables require strutting in accordance with Sitework clause 6.4 - S8.

Lightweight non-loadbearing partitions which weigh no more than 1.0kN (101.9kg) per metre run and are parallel to the joists may be supported by one or two additional joists placed immediately beneath them. The partitions should be fixed through the floor decking into the joist(s) beneath. In tables 1 and 2, one additional joist is generally sufficient. Where two additional joists are needed, the spans are marked with an asterisk (eg 1.76\*). For similar lightweight partitions which run at right-angles to the joists, the maximum spans in Tables 1 and 2 should be reduced by 10%. For all other additional loads, joist sizes should be designed by an Engineer in accordance with Technical Requirement R3.

# 6.4 Timber and concrete upper floors

**Table 1 - Permissible clear spans for domestic floor joists - strength class C16**

Imposed load not exceeding 1.5 kN/m<sup>2</sup>  
Service Class 1 or 2

Dead Load gk [kN/m <sup>2</sup> ] excluding self-weight of joist										
Size of joist		gk not more than 0.25			gk not more than 0.50			gk not more than 1.25		
		Spacing of joists [mm]								
		400	450	600	400	450	600	400	450	600
Breadth [mm]	Depth [mm]	Maximum clear span [m]								
38	97	1.76*	1.66*	1.43	1.64*	1.55*	1.35	1.43	1.35	0.71
38	120	2.36*	2.23*	1.94	2.18*	2.07*	1.80	1.86	1.77	1.55
38	145	2.85*	2.74*	2.48	2.68*	2.58*	2.32	2.33	2.22	1.96
38	170	3.33*	3.20*	2.90	3.14*	3.02*	2.73	2.74	2.63	2.37
38	195	3.81*	3.67*	3.32	3.59*	3.45*	3.12	3.14	3.01	2.71
38	220	4.29*	4.13*	3.74	4.05*	3.89*	3.52	3.53	3.39	3.06
44	97	1.89*	1.78*	1.54	1.76*	1.67*	1.45	1.53	1.45	1.27
44	120	2.48*	2.39*	2.08	2.33*	2.21*	1.94	1.98	1.88	1.66
44	145	2.99*	2.88*	2.61	2.82*	2.71*	2.45	2.46	2.36	2.09
44	170	3.50*	3.37*	3.05	3.30*	3.17*	2.87	2.88	2.77	2.50
44	195	4.00*	3.85*	3.49	3.78*	3.63*	3.29	3.30	3.17	2.86
44	220	4.51*	4.33*	3.94	4.25*	4.09*	3.71	3.72	3.57	3.23
47	97	1.95*	1.84*	1.60	1.81*	1.72*	1.50	1.57	1.49	1.31
47	120	2.54*	2.44*	2.15	2.39*	2.27*	2.00	2.04	1.94	1.71
47	145	3.06*	2.94*	2.67	2.88*	2.77*	2.51	2.52	2.42	2.15
47	170	3.58*	3.44*	3.12	3.37*	3.24*	2.94	2.95	2.83	2.56
47	195	4.09*	3.94*	3.57	3.86*	3.71*	3.36	3.38	3.24	2.93
47	220	4.60*	4.43*	4.02	4.34*	4.18*	3.79	3.80	3.65	3.30
50	97	2.00*	1.89*	1.65	1.87*	1.77*	1.54	1.61	1.53	1.34
50	120	2.59*	2.49*	2.22	2.44*	2.34*	2.05	2.09	1.99	1.75
50	145	3.12*	3.00*	2.72	2.94*	2.83*	2.56	2.57	2.47	2.21
50	170	3.65*	3.51*	3.19	3.44*	3.31*	3.00	3.01	2.89	2.61
50	195	4.17*	4.02*	3.65	3.94*	3.79*	3.44	3.45	3.31	3.00
50	220	4.70*	4.52*	4.11	4.43*	4.26*	3.87	3.88	3.73	3.38
63	97	2.23*	2.11*	1.84	2.07*	1.97*	1.72	1.78	1.70	1.50
63	120	2.80*	2.69*	2.44	2.64*	2.54*	2.28	2.30	2.19	1.94
63	145	3.37*	3.24*	2.95	3.18*	3.06*	2.78	2.79	2.68	2.42
63	170	3.94*	3.79*	3.45	3.72*	3.58*	3.25	3.26	3.13	2.84
63	195	4.50*	4.33*	3.94	4.25*	4.09*	3.72	3.73	3.58	3.25
63	220	5.06*	4.87*	4.44	4.78*	4.60*	4.18	4.20	4.04	3.66
75	120	2.96*	2.85*	2.59	2.79*	2.69*	2.44	2.45	2.35	2.09
75	145	3.56*	3.43*	3.12	3.37*	3.24*	2.94	2.95	2.84	2.57
75	170	4.16*	4.01*	3.65	3.93*	3.79*	3.44	3.45	3.32	3.01
75	195	4.75*	4.58*	4.17	4.49*	4.33*	3.94	3.95	3.80	3.45
75	220	5.34*	5.15*	4.70	5.05*	4.87*	4.43	4.45	4.28	3.88
ALS/CLS										
38	140	2.75*	2.64*	2.39	2.59*	2.49*	2.21	2.24	2.13	1.88
38	184	3.60*	3.46*	3.14	3.39*	3.26*	2.95	2.96	2.84	2.56
38	235	4.58*	4.40*	3.99	4.32*	4.15*	3.76	3.77	3.62	3.27
89	184	4.74*	4.57*	4.17	4.48*	4.32*	3.94	3.95	3.80	3.45
89	235	5.99*	5.78*	5.29	5.68*	5.48*	5.00	5.01	4.83	4.39

\* Two additional joists required

■ Normal bearing of 40mm to be doubled



**Table 2 - Permissible clear spans for domestic floor joists - strength class C24**

Imposed load not exceeding  $q_k = 1.5 \text{ kN/m}^2$  or  $Q_k = 0.90 \text{ kN}$   
Service Class 1 or 2

Dead Load $g_k$ [kN/m <sup>2</sup> ] excluding self-weight of joist		g <sub>k</sub> not more than 0.25			g <sub>k</sub> not more than 0.50			g <sub>k</sub> not more than 1.25		
Size of joist		Spacing of joists [mm]								
		400	450	600	400	450	600	400	450	600
Breadth [mm]	Depth [mm]	Maximum clear span [m]								
38	97	2.05*	1.94*	1.68	1.91*	1.80*	1.57	1.64	1.56	1.37
38	120	2.63*	2.53*	2.26	2.48*	2.38*	2.09	2.13	2.02	1.78
38	145	3.17*	3.05*	2.77	2.99*	2.87*	2.60	2.61	2.51	2.25
38	170	3.71*	3.57*	3.24	3.50*	3.36*	3.05	3.06	2.94	2.65
38	195	4.25*	4.08*	3.71	4.00*	3.85*	3.49	3.50	3.36	3.04
38	220	4.78*	4.60*	4.17	4.51*	4.33*	3.93	3.95	3.79	3.42
44	97	2.19*	2.07*	1.81	2.04*	1.93*	1.69	1.75	1.66	1.46
44	120	2.77*	2.66*	2.41	2.61*	2.50*	2.24	2.26	2.15	1.90
44	145	3.33*	3.20*	2.91	3.14*	3.02*	2.74	2.75	2.64	2.38
44	170	3.90*	3.75*	3.40	3.67*	3.53*	3.20	3.22	3.09	2.79
44	195	4.46*	4.29*	3.90	4.21*	4.04*	3.67	3.68	3.54	3.20
44	220	5.01*	4.82*	4.39	4.73*	4.55*	4.13	4.15	3.98	3.61
47	97	2.26*	2.14*	1.87	2.10*	1.99*	1.74	1.80	1.71	1.51
47	120	2.83*	2.72*	2.47	2.67*	2.56*	2.31	2.32	2.21	1.96
47	145	3.40*	3.27*	2.97	3.21*	3.09*	2.80	2.81	2.70	2.44
47	170	3.98*	3.83*	3.48	3.76*	3.61*	3.28	3.29	3.16	2.86
47	195	4.55*	4.38*	3.98	4.30*	4.13*	3.75	3.77	3.62	3.27
47	220	5.12*	4.93*	4.48	4.83*	4.65*	4.23	4.24	4.08	3.69
50	97	2.32*	2.20*	1.92	2.15*	2.04*	1.79	1.85	1.76	1.55
50	120	2.88*	2.77*	2.52	2.72*	2.62*	2.37	2.38	2.27	2.01
50	145	3.48*	3.34*	3.04	3.28*	3.15*	2.86	2.87	2.76	2.50
50	170	4.06*	3.91*	3.55	3.83*	3.69*	3.35	3.36	3.23	2.92
50	195	4.64*	4.47*	4.07	4.38*	4.22*	3.88	3.85	3.69	3.35
50	220	5.22*	5.03*	4.58	4.93*	4.75*	4.32	4.33	4.16	3.77
63	97	2.52*	2.43*	2.14	2.38*	2.26*	1.99	2.03	1.94	1.72
63	120	3.11*	2.99*	2.72	2.94*	2.83*	2.57	2.57	2.47	2.22
63	145	3.74*	3.60*	3.28	3.54*	3.40*	3.09	3.10	2.98	2.70
63	170	4.37*	4.21*	3.84	4.13*	3.98*	3.62	3.63	3.49	3.17
63	195	5.00*	4.81*	4.39	4.72*	4.55*	4.14	4.15	4.00	3.62
63	220	5.61*	5.41*	4.94	5.31*	5.12*	4.66	4.68	4.50	4.08
75	120	3.29*	3.17*	2.88	3.11*	2.99*	2.72	2.73	2.62	2.38
75	145	3.96*	3.81*	3.48	3.74*	3.60*	3.28	3.29	3.16	2.87
75	170	4.62*	4.45*	4.06	4.37*	4.21*	3.83	3.85	3.70	3.36
75	195	5.27*	5.08*	4.64	4.99*	4.81*	4.38	4.40	4.23	3.85
75	220	5.92*	5.71*	5.22	5.61*	5.41*	4.93	4.95	4.76	4.33
ALS/CLS										
38	140	3.07*	2.95*	2.67	2.89*	2.77*	2.51	2.52	2.42	2.15
38	184	4.01*	3.86*	3.50	3.78*	3.63*	3.29	3.31	3.17	2.87
38	235	5.10*	4.90*	4.46	4.81*	4.62*	4.20	4.21	4.04	3.65
89	184	5.25*	5.07*	4.63	4.98*	4.80*	4.38	4.39	4.23	3.85
89	235	6.64*	6.41*	5.87	6.30*	6.08*	5.56	5.57	5.37	4.89

\* Two additional joists required

■ Normal bearing of 40mm to be doubled

# 6.4 Timber and concrete upper floors

## INDEX

<b>B</b>		<b>J</b>		<b>S</b>	
Bearings	3, 6, 8, 12	Joist hangers	2, 5, 6, 8	Separating walls	3
Boarding	10, 11	Joist sizes	1	Shrinkage	2
<b>C</b>		Joist spacing	1, 4, 6	Sound transmission	4, 5
Chimneys	3	<b>L</b>		Span	1, 8
Chipboard	11	Levelling	6	Strength class	1
Clearance	6	Lightweight partitions	1	Structural steel	3, 5, 7
Concrete	4, 5, 12	<b>M</b>		Strutting	2, 5, 8
<b>D</b>		Masonry partitions	2	Supporting structure	1
Dead loads	1	Metal web joists	7, 8, 9, 10	<b>T</b>	
Decking	4, 5, 10, 11	Moisture	4, 5	Timber floors	4, 5
Drilling	9	Multiple joists	7	Timber joists	9, 10
<b>E</b>		<b>N</b>		Trimming joists	2, 6
End bearings	3	Notching	9		
<b>F</b>		<b>O</b>			
Fire spread	3	Oriented strand board	11		
Fire-stopping	13	Overlapping joists	10		
Fixings	4	<b>P</b>			
Floating floors	12	Plywood	11		
Flooring	3	Pre-cast concrete	12		
<b>I</b>		Proprietary systems	5, 12		
Imposed loads	4	<b>R</b>			
In-situ concrete	12	Reinforcement	5, 12		
I-joists	7, 8, 9, 10	Restraint strapping	3, 5, 9, 12		

# Chapter 6.5

## Steelwork

---



# 6.5 Steelwork

## CONTENTS

	Clause	Page
<b>DESIGN</b>		
Design standards	D1	1
Structural design	D2	1
Padstones	D3	1
<b>MATERIALS</b>		
Materials standards	M1	1
Steelwork	M2	1
Padstones	M3	1
Connections	M4	1
<b>SITWORK</b>		
Sitework standards	S1	2
Steelwork	S2-S3	2
<b>APPENDIX 6.5-A</b>		
Design tables for support of masonry partitions (no floor loads)		2
Table 1 - Load of partition to be supported		2
Table 2 - Size of steel beam supporting partition		2
Table 3 - Size of padstone		3
<b>APPENDIX 6.5-B</b>		
Design tables for support of floors (no masonry partition loads)		3
Table 4 - Size of steel beam supporting floor		4
Table 5 - Size of padstone		4
<b>APPENDIX 6.5-C</b>		
Connection of beams supporting floors		5
<b>INDEX</b>		5

## SCOPE

This Chapter gives guidance on meeting the Technical Requirements and recommendations for steelwork to support masonry partitions, timber floors and to trim floor voids.

## DESIGN STANDARDS

### 6.5 - D1 Design shall meet the Technical Requirements

Design that follows the guidance below will be acceptable for steelwork supporting either masonry partitions or floors.

## STRUCTURAL DESIGN

### 6.5 - D2 Steelwork shall be designed to support and transmit loads to the supporting structure without undue movement or deflection

Steelwork (including its support and any connections) should be either:

- designed by an Engineer in accordance with Technical Requirement R5, or
- where appropriate, detailed according to the designs shown in this Chapter.

The designs shown in this Chapter are in accordance with BS EN 1993-1-1 using grade S275 steel and therefore meet statutory requirements.

It should be noted that the information given in this Chapter has been prepared primarily to assist builders in providing proper support to masonry partitions and floors. The designs given will not always be the most economic and an engineer may be able to design a smaller section beam for a particular situation.

Items to be taken into account include:

#### (a) support of masonry partitions

Where appropriate, masonry partitions may be supported by steelwork selected in accordance with Appendix 6.5-A.

Care should be taken during construction to avoid the problem of out-of-true masonry being only partly supported by steelwork.

#### (b) support of floors

Timber floors can be supported by steelwork.

Where appropriate, steelwork should be in accordance with Appendices 6.5-B and 6.5-C.

The timber floor should be in accordance with Chapter 6.4 'Timber and concrete upper floors' (each section), including proper allowance for shrinkage of timber joists supported by steelwork.

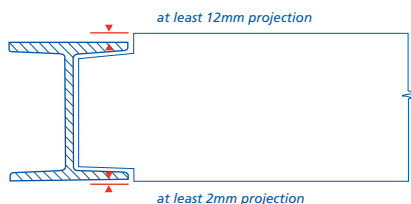

#### (c) support of steelwork

Steelwork may need to be supported on padstones to distribute loads safely.

Masonry should be in accordance with Chapter 6.1 'External masonry walls' (each section) or Chapter 6.3 'Internal walls' (each section), as appropriate.

#### (d) steelwork to steelwork connection

Connections between steel beams should be designed.

Where appropriate, steelwork beam-to-beam connections should be in accordance with Appendix 6.5-C.

Appendix 6.5-C uses bolted connections (using black bolts) or welding. Connections requiring the use of other forms of connection (such as high strength friction grip bolts) should be designed by an Engineer in accordance with Technical Requirement R5.

#### (e) durability

Steelwork should be given a protective coating system to ensure durability. For details, refer to Sitework clause 6.5-S3.

#### (f) fire resistance

Steelwork should be provided with the level of fire resistance required by Building Regulations.

## PADSTONES

### 6.5 - D3 Padstones shall distribute point loads safely to the supporting structure

Where a steel beam is supported by masonry, a padstone may be required to spread the load over a sufficiently large area of the masonry to prevent overstressing. A padstone may be necessary (see Table 3, Appendix 6.5-A and Table 5, Appendix 6.5-B for sizes).

Where the inner leaf is used to provide a major contribution to the thermal insulation of a cavity wall, any padstone that is needed should have similar thermal properties to the masonry used for the rest of the inner leaf or precautions should be taken to prevent cold bridging.

## MATERIALS STANDARDS

### 6.5 - M1 All materials shall:

- (a) meet the Technical Requirements
- (b) take account of the design

Materials that comply with the design and the guidance below will be acceptable for steelwork supporting either masonry partitions or floors.

Materials for steelwork supporting either masonry partitions or floors shall comply with all relevant standards, including those listed below. Where no standard exists, Technical Requirement R3 applies (see Chapter 1.1 'Introduction to the Standards and Technical Requirements').

References to British Standards and Codes of Practice include those made under the Construction Products Directive (89/106/EEC) and, in particular, appropriate European Technical Specifications approved by a European Committee for Standardisation (CEN).

## STEELWORK

### 6.5 - M2 Steelwork shall be of sufficient strength and durability

Steelwork will be acceptable if it complies with Clause M1 above and is based on:

BS 4 Part 1	Structural steel sections : Specification for hot-rolled sections, or
BS 4848	Specification for hot-rolled structural steel sections.

To ensure durability, steelwork should be given a protective coating system. For steelwork which is to be bolted (using black bolts) or not connected, an acceptable coating system is one coat of high build zinc phosphate primer and one coat of bituminous paint. Where welding is to be carried out, use the protective coating system specified by the designer.

## PADSTONES

### 6.5 - M3 Padstones shall distribute point loads safely to the supporting structure

Details of padstones are given in Table 3, Appendix 6.5-A and Table 5, Appendix 6.5-B. For the design of padstones see Design section, clause D2.

## CONNECTIONS

### 6.5 - M4 Connections shall be chosen to be capable of supporting and transmitting the intended loads

Connections should comply with the design. Bolts will be acceptable if they comply with the design and are based on the relevant British Standards, including:

BS 4190	Specification for ISO metric black hexagon bolts, screws and nuts
BS 4395	Specification for high strength friction grip bolts and associated nuts and washers for structural engineering
BS 4604	Specification for the use of high strength friction grip bolts in structural steelwork.

Welded connections should comply with:

BS 5135	Specification for arc welding of carbon and carbon-manganese steels.
---------	--

## SITWORK STANDARDS

### 6.5 - S1 All sitework shall:

- (a) meet the Technical Requirements
- (b) take account of the design
- (c) follow established good practice and workmanship

Construction that follows the design and the guidance below will be acceptable for steelwork supporting either masonry partitions or floors.

## STEELWORK

### 6.5 - S2 Steelwork shall be installed to achieve the required structural performance

Items to be taken into account include:

#### (a) the section size and grade detailed in the design

When materials are delivered to site, check that they conform with either:

- the Engineer's design, or
- the steelwork sizes given in the Appendices to this Chapter.

#### (b) bearings

Bearings for steelwork should be:

- at least 100mm, and
- clean, dry and level.

Padstones may be required in accordance with:

- the Engineer's design, or
- the guidance given in Table 3, Appendix 6.5-A and Table 5, Appendix 6.5-B.

#### (c) connections

Where steelwork-to-steelwork connections are required, follow either:

- the Engineer's design, or
- the guidance given in Appendix 6.5-C.

Only weld, cut or drill steelwork if it is required by the design.

### 6.5 - S3 Steelwork shall be protected to achieve the required durability

To ensure durability, steelwork should be given a protective coating system.

For steelwork which is to be bolted (using black bolts), or not connected, an acceptable coating system is one coat of high build zinc phosphate primer and one coat of bituminous paint.

Where steelwork is to be protected by intumescent paint for fire purposes, manufacturers' recommendations should be followed.

#### STEELWORK - UNGALVANIZED

Internal and external steelwork that has not been galvanized should be protected with at least:

- two coats of zinc phosphate primer, and
- a suitable decorative finish where required.

#### STEELWORK - GALVANIZED

Unless steelwork is galvanized to a rate of 460g/m<sup>2</sup>, it should be protected as described for ungalvanized.

## APPENDIX 6.5-A

### DESIGN TABLES FOR SUPPORT OF MASONRY PARTITIONS (no floor loads)

Steel beams in accordance with the Tables 1, 2 and 3 in this Appendix will be acceptable to NHBC for the support of masonry partitions, if:

- the masonry partition is not more than 2.7m in height, *and*
- steel beams only support the weight of the masonry partition and self weight, *and*
- steel beams span no more than 4.0m, *and*
- the masonry partition is built centrally on the steelwork beam, *and*
- the masonry partition is of one of the types detailed in Table 1, *and*
- padstones are provided, where required, *and*
- the masonry supporting the steel beam is of at least 2.8N/mm<sup>2</sup> blockwork (workface size 440mm x 215mm) or brickwork and the beam supports do not occur over a door or window opening.

If *any* of the above limitations are not met, steelwork should be designed in accordance with Technical Requirement R5.

#### Method of applying tables

- 1 Check that the situation is within all the limitations detailed above.
- 2 Identify the masonry partition construction and thickness.
- 3 Use Table 1 to establish the load per metre run.
- 4 Check the span of the beam(s).
- 5 Use Table 2 to determine a suitable steel section size.
- 6 Check whether padstones are required - see Table 3.

(To help in applying the tables, a worked example is given at the end of this Appendix.)

Table 1 - Load of partition to be supported

Type of masonry for supported partition (not more than 2.7m high and plastered both sides)	Maximum masonry density [kg/m <sup>3</sup> ]	Structural thickness [mm]		
		100	90	75
		Load [kN/m run]		
Dense masonry	2000	6.8	6.2	5.4
Medium masonry	1400	5.1	4.8	4.2
Lightweight masonry	800	3.5	3.3	2.9

Table 2 - Size of steel beam supporting partition

Partition load (from Table 1) [kN/m run]	Clear span of beam [m]	Smallest suitable Universal Beam size [mm x mm x kg/m]
Less than 3	up to 4 over 4	127 x 76 x 13 see Note 2
3 to 5	up to 3 3 to 3.5 3.5 to 4 over 4	127 x 76 x 13 152 x 89 x 16 178 x 102 x 19 see Note 2
5 to 7	up to 2.5 2.5 to 3 3 to 4 over 4	127 x 76 x 13 152 x 89 x 16 178 x 102 x 19 see Note 2

#### Notes to Table 2

- 1 For spans up to 4m, Universal Column 152mm x 152mm x 23kg/m, which is the smallest size available, may be used.
- 2 For spans over 4m, beams should be designed by an Engineer in accordance with Technical Requirement R5.

**Table 3 - Size of padstone**

Type of masonry for supported partition (not more than 2.7m high and plastered both sides)	Thickness of wall supporting beam [mm]						Minimum depth of padstone [mm]
	100	125	140	150	190	215	
Dense masonry	215	190	185	180	165	155	150
Medium masonry	155	140	135	130	120	110	150
Lightweight masonry	95	85	80	75	70	70	150

**Notes to Table 3**

- Padstones are not necessary where the flange dimension of the beam exceeds the length of the padstone given in this table.
- When steelwork is in line with the wall supporting it (ie when acting as a lintel over an opening):
  - the flange dimension of the beam should not be more than 50mm greater than the thickness of the supporting wall, **and**
  - the minimum length of padstone should be 200mm, **and**
  - the padstone depth should match the coursing of adjacent masonry, **and**
  - the web of the beam should be over the centre of the wall.
- The minimum length of steel bearing onto padstone should be 100mm.
- Padstones can be formed from:
  - in-situ concrete
  - precast concrete
  - concrete blocks
  - clay bricks.

Padstones should be formed in one unit with a minimum compressive strength of 10N/mm<sup>2</sup>.

For padstone sizes less than 215mm x 100mm, engineering bricks will be suitable.

**Worked Example**

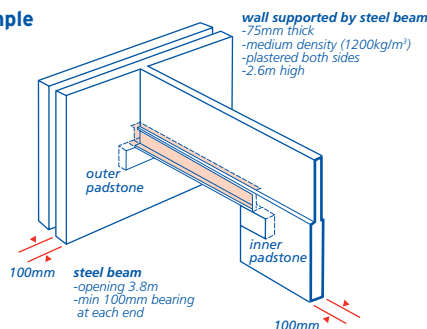

**Procedure**

- Using information about the supported wall and Table 1:
  - load per metre run = 4.2kN/m.
- Using the load per metre run, the span of the beam and Table 2:
  - suitable section size = 178 x 102 x 19 UB (The alternative 152 x 152 x 23 UC is not suitable as it is too wide for the inner padstone/wall.)
- Using information about the wall supporting the beam (100mm thick), the walls supported by the beam (medium density block) and Table 3:
  - minimum padstone size = 155mm long = 150 mm deep
  - outer padstone (beam at right angles to wall):
    - minimum length = 155mm (as this is greater than the flange dimension of the steel section obtained in 2 above - 102mm - a padstone is required to distribute the load)
    - minimum depth = 150mm
    - thickness = 100mm, to match blockwork (The actual length and depth of a padstone could be greater to suit masonry coursing.)
  - inner padstone (beam in line with the wall):
    - minimum length = 200mm (see Note 2 to Table 3)
    - minimum depth = 150mm
    - thickness = 100mm, to match blockwork.

**Note**

Beam supports should not occur above window or door openings

**APPENDIX 6.5-B**

**DESIGN TABLES FOR SUPPORT OF FLOORS (no masonry partition loads)**

**Limitations**

Steel beams in accordance with Tables 4 and 5 in this Appendix will be acceptable to NHBC for the support of floors, if:

- the floor construction is of decking (softwood boarding, chipboard, oriented strand board or plywood) on timber joists with a plasterboard ceiling underneath which is given either a plaster skim coat or a plastic finish (Artex or similar), **and**
- allowance has been made of 0.5kN/m<sup>2</sup> for self weight (floor and ceiling load) **and**
- the floor does not support masonry partitions, **and**
- any lightweight partition (such as plasterboard on timber studwork or proprietary product) is non-loadbearing, **and**
- padstones are provided, where required, **and**
- clear span of beam does not exceed 4.4m, **and**
- connections between steelwork beams are in accordance with Appendix 6.5-C or are designed by an Engineer, **and**
- the floor support is one of the methods shown in Figure 1.

If **any** of the above limitations are not met, steelwork should be designed by an Engineer in accordance with Technical Requirement R5.

**Method of applying tables**

- Check that the situation is within all the limitations detailed above.
- Using Figure 1, determine the area supported by the beam(s).
- Check the span of the beam(s).
- Use Table 4 to determine a suitable steel section size.
- Check whether padstones are required by Table 5.
- If steel beam-to-steel beam connections are required, use Appendix 6.5-C.



**Figure 1 - Effective areas supported by steel beams**

If any area shown as 'void' contains a staircase, add 2m<sup>2</sup> to the effective area supported by any beam which supports (partially or fully) that staircase.

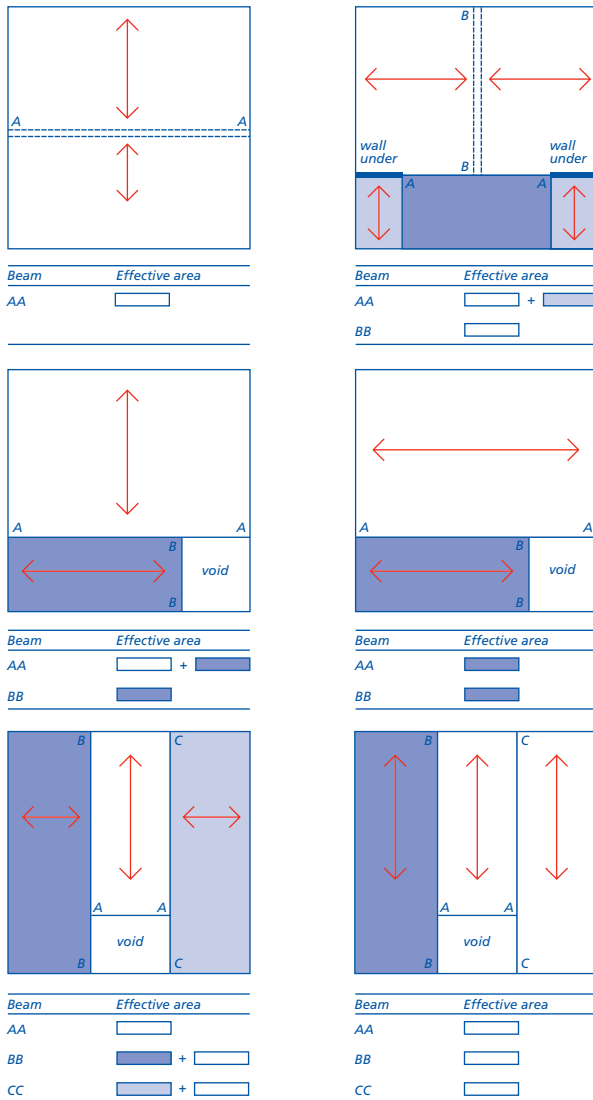

**Table 4 - Size of steel beam supporting floor**

Effective area supported (m <sup>2</sup> )	Effective trimmer span = clear span + 100mm (m)	Smallest suitable steel section size (mm x mm x kg/m)	
		Universal beam	Universal column
0 to 20	0 to 2.0	127 x 76 x 13	152 x 152 x 23
0 to 20 20 to 30	2 to 2.5	127 x 76 x 13 152 x 89 x 16	152 x 152 x 23 152 x 152 x 23
0 to 10 10 to 20 20 to 30	2.5 to 3	127 x 76 x 13 152 x 89 x 16 178 x 102 x 19	152 x 152 x 23 152 x 152 x 23 152 x 152 x 23
0 to 10 10 to 30 30 to 40	3 to 3.5	127 x 76 x 13 178 x 102 x 19 203 x 133 x 25	152 x 152 x 23 152 x 152 x 23 152 x 152 x 30
0 to 10 10 to 20 20 to 30 30 to 40 40 to 50	3.5 to 4	152 x 89 x 16 178 x 102 x 19 203 x 102 x 23 203 x 102 x 30 see Note 1	152 x 152 x 23 152 x 152 x 23 152 x 152 x 23 152 x 152 x 30 152 x 152 x 37
0 to 10 10 to 20 20 to 30 30 to 40 40 to 50	4 to 4.5	203 x 102 x 23 203 x 133 x 25 203 x 133 x 30 see Note 1 see Note 1	152 x 152 x 23 152 x 152 x 23 152 x 152 x 30 152 x 152 x 37 203 x 203 x 46

**Note to Table 4**

1 Beams should be designed by an Engineer in accordance with Technical Requirement R5.

**Table 5 - Size of padstone**

Effective area supported (as used in Table 4) [m <sup>2</sup> ]	Minimum padstone size [mm]					
	Thickness of wall supporting steel beam [mm]					
	Up to 105		105 to 155		156 to 216	
	length	depth	length	depth	length	depth
Up to 10	95	150	80	150	70	150
10 to 20	185	150	160	150	140	150
20 to 30	275	150	240	150	210	150
30 to 40	365	215	320	150	280	150
40 to 50	455	300	400	215	345	215

**Notes to Table 5**

- See limitations listed at the beginning of this Appendix.
- Padstones are not necessary where the flange dimension of the beam exceeds the length of the padstone given in this table.
- Where the steelwork is in line with the wall supporting it (ie acting to form a lintel over an opening):
  - the steel flange dimension should not be more than 50mm greater than the thickness of the supporting wall, **and**
  - the minimum length of padstone should be 200mm, **and**
  - the padstone depth should match the coursing of adjacent masonry, **and**
  - the web of the beam should be over the centre of the wall.
- Padstones can be formed from:
  - in-situ concrete
  - precast concrete
  - concrete blocks
  - clay bricks.

Padstones should be formed in one unit with a minimum compressive strength of 10N/mm<sup>2</sup>.

For padstone sizes less than 215mm x 100mm, engineering bricks will be suitable.

**APPENDIX 6.5-C**
**Connection of beams supporting floors**

The connection methods shown in this Appendix (determined using Appendix 6.5-B) are suitable for connecting steel beams used to support floor loads

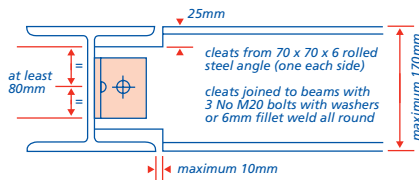

JOINT BETWEEN BEAMS OF SIMILAR SIZE  
(neither beam deeper than 170mm)

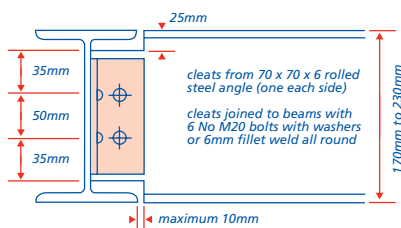

JOINT BETWEEN BEAMS OF SIMILAR SIZE  
(beams 170mm to 230mm deep)

**Limitations**

Limitations on the use of this method are:

- neither beam is to support masonry partitions, **and**
- both beams have been chosen from Table 4 of Appendix 6.5-B, **and**
- beams do not differ in depth by more than 40mm.

The following connections should be designed by an Engineer in accordance with Technical Requirement R5:

- between steel sections which differ in depth by more than 40mm, or
- between steel sections, one of which carries floor loads and one of which carries a masonry partition, or
- between steel sections which have not been derived using Appendix 6.5-B, or
- between steel sections which both carry masonry partitions.

**INDEX**

<b>B</b>		<b>M</b>	
Beams	2, 4	Masonry partitions, support	1, 2
Bearings	2	<b>P</b>	
Bolted connections	1	Padstones	1, 3, 4
<b>C</b>		Partitions	2
Clear span	4	Point loads	1
Coatings	1, 2	<b>S</b>	
Cold bridging	1	Section size	2
Connections	1, 2, 5	Staircase	4
<b>D</b>		Support	1, 2, 3
Design, structural	1	<b>T</b>	
Durability	1, 2	Timber floors	1
<b>E</b>		<b>V</b>	
Effective areas	4	Voids	4
<b>F</b>		<b>W</b>	
Fire resistance	1	Welding	1, 2
Floors, support	1, 3		
<b>G</b>			
Galvanized steel	2		
Grade	2		
<b>I</b>			
Intumescent paint	2		



# Chapter 6.6

## Staircases

---



# 6.6 Staircases

## CONTENTS

	Clause	Page
<b>DESIGN</b>		
Design standards	D1	1
Statutory requirements	D2	1
Safe transmission of loads	D3	1
Staircase width and headroom	D4	1
Design of steps	D5	1
Landings	D6	2
Handrails	D7	2
Guarding	D8	2
Fire Precautions	D9	2
Lighting	D10	2
Provision of information	D11-D12	2
<b>MATERIALS</b>		
Materials standards	M1	3
Staircase units	M2	3
Timber and wood-based products	M3	3
In-situ and precast concrete	M4	3
Fixings	M5	3
<b>SITWORK</b>		
Sitework standards	S1	3
Location and fixing	S2	3
Timber staircases	S3-S4	3 - 4
Concrete staircases	S5-S7	4
Steel staircases	S8-S9	4
Handrails and balustrades	S10-S11	4
Protection of finished work	S12	5
<b>APPENDIX 6.6-A</b>		
Design aid for rise and going		6
<b>INDEX</b>		7

## SCOPE

This Chapter gives guidance on meeting the Technical Requirements and recommendations for staircases.

## DESIGN STANDARDS

### 6.6 - D1 Design shall meet the Technical Requirements

Design that follows the guidance below will be acceptable for staircases.

## STATUTORY REQUIREMENTS

### 6.6 - D2 Design shall comply with all relevant statutory requirements

Design should be in accordance with relevant Building Regulations and other statutory requirements.

## SAFE TRANSMISSION OF LOADS

### 6.6 - D3 Design shall ensure that loads are properly supported and transmitted to the supporting structure without undue movement, deflection or deformation

Generally, all stairs and staircases should comply with BS 5395 : Parts 1 and 2.

Items to be taken into account include:

#### (a) timber staircase construction

Timber domestic staircases with straight flights and quarter- or half-landings should comply with BS 585. Particular attention should be paid to the performance requirements for strength, deflection and vibration under load, given in BS 585 : Part 2.

The method of fixing flights to the surrounding structure should be specified.

#### (b) concrete staircase construction

Reinforced concrete staircases should be designed to BS EN 1992-1-1 and comply with Chapter 2.1 'Concrete and its reinforcement' (each section) and, where appropriate, designed by an Engineer in accordance with Technical Requirement R5.

#### (c) steel staircase construction

Steel staircases should be designed to BS EN 1993-1-1.

#### (d) proprietary staircase construction

Proprietary staircases should:

- comply with an assessment in accordance with Technical Requirement R3
- be suitable for their required use and location.

#### (e) differential movement

When considering differential movement in relation to setting out, levels and finishes, allowances should be made for:

- casting tolerances
- deflection under load
- foundation settlement
- creep and shrinkage
- storey height.

## STAIRCASE WIDTH AND HEADROOM

### 6.6 - D4 Staircase design shall ensure adequate provision for:

#### (a) headroom

The minimum headroom above stairs should be measured vertically from the pitch line. The clear headroom ( $h$ ) over the entire length and width of a stairway, including landings, should be 2.0m.

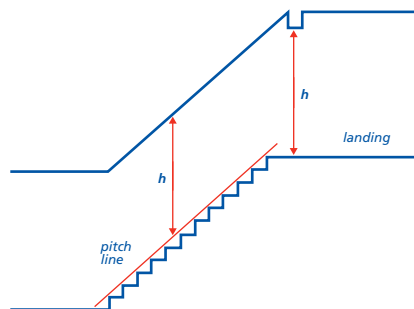

#### (b) minimum unobstructed width

No recommendations are given for minimum widths in England, Wales and the Isle of Man. Where staircases form part of means of escape, reference should be made to the relevant Building Regulations.

Dimensions for stair widths in Scotland and Northern Ireland should be in accordance with relevant Statutory Requirements.

## DESIGN OF STEPS

### 6.6 - D5 The design of steps shall allow safe use of the staircase

Items to be taken into account include:

#### (a) pitch

The maximum angle of pitch of a stairway should not exceed:

- 42° for private stairs
- 38° for common or access stairs.

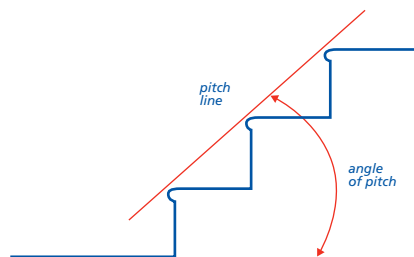

The dimensions for maximum rise and minimum going should be:

Type of stairs	Maximum rise [mm]	Minimum going [mm]
Private stairs	220	220
Common stairs (not Scotland)	190	250
Access stairs (Scotland)	190	250

The dimensions of the rise ( $R$ ) and the going ( $G$ ) should usually be related so that  $2R+G$  is between 550mm and 700mm.

A design aid giving the relationship between rise and going is given in Appendix 6.6-A.

Further information on staircase design may be found in BS 5395.

#### (b) consistent rise and going

In each flight of stairs all the steps should have the same rise and going.

The thicknesses of screeds and floor finishes should be taken into account.

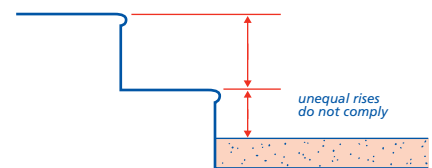

#### (c) tapered treads and winders

The rise of tapered treads should be the same as that of adjacent parallel treads. The going should be uniform and not less than the going of the associated straight flight. The going should be measured from the centre line of the straight flight (as shown below).

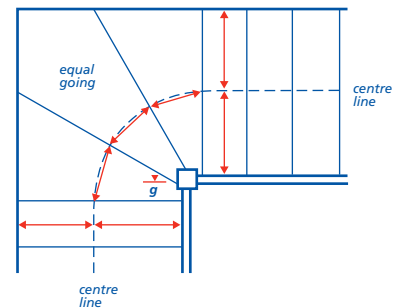

	Minimum going (g) [mm]
England and Wales	50
Scotland	50
Northern Ireland	50
Isle of Man	50

#### (d) safe foothold

All steps should have level treads.

Stairs with open risers should have treads that overlap 16mm minimum.

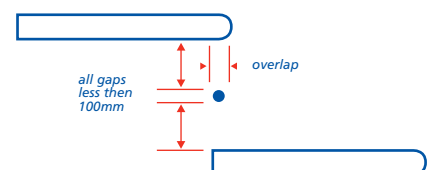

Where stairs are open to the weather or may otherwise become wet, a non-slip finish or an insert to each tread should be specified.

# 6.6 Staircases

## LANDINGS

### 6.6 - D6 Landings shall be designed to allow safe use of the staircase

Landings should be provided at the top and bottom of every flight. The width and depth of landings should be at least the same as the width of the stair.

Landings should be properly framed to provide full support and secure fixings for flights, nosings, newels, etc.

Where pivot windows are being used, they should not obstruct the landing area or stair flight when in the open position.

Generally, door swings should not obstruct landings. However, a door may open across the bottom landing of a flight of private stairs if the swing is at least 400mm from the first tread and the dwelling is not over two storeys high.

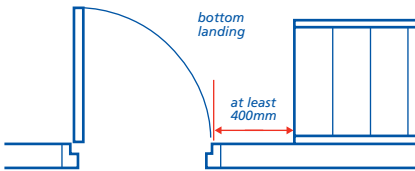

## HANDRAILS

### 6.6 - D7 Handrails shall be designed to provide a safe handhold

A handrail is required to all flights of stairs that rise over 600mm.

Where winders are used, Building Regulations (Northern Ireland) require a handrail to be fitted on the side where tapered treads have the greater going.

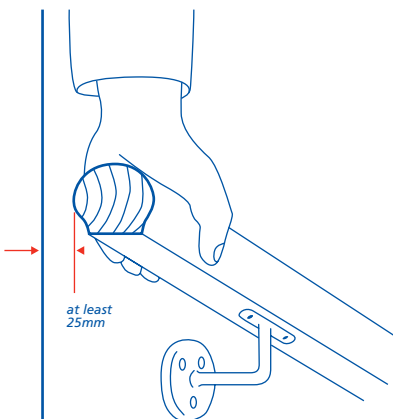

Handrails should be at a height between 900mm (840mm in Scotland) and 1000mm.

Design should ensure:

- a firm handhold
- that trapping or injuring the hand is prevented
- a minimum 25mm clearance at the back of the handrail
- secure fixing

- that handrail ends do not project to catch clothing, etc.

## GUARDING

### 6.6 - D8 Guarding shall be designed to prevent accidents by falling

Items to be taken into account include:

#### (a) resistance to loads

Guarding should be:

- capable of resisting a horizontal force of 0.36kN/m at its minimum required height
- a solid wall or balustrading.

Where guardrails or balustrades are long, the newel posts may not be sufficient to transfer horizontal forces to the structure and intermediate posts may be needed.

The method of fixing newels should be specified (eg through-bolted to joists).

Any glazing in the guarding should be toughened or laminated glass, or glass blocks. Wired glass is not regarded as safe for this purpose and should not be used.

#### (b) dimensional requirements

Guarding should be provided along the full length of the open sides of all stairs and landings when the drop is more than 600mm at any point. To comply with relevant Building Regulations, guarding may be required where a stair abuts an opening window.

Guarding is not needed when the rise is less than 600mm and when the stair or landing is not a means of escape.

Balustrading should be designed so that it is not easily climbed by children.

No opening in the balustrade should be large enough for a 100mm diameter sphere to pass through.

Type of stairs	Minimum guarding height [mm]	
	flights	landings
Private stairs (England, Wales, Northern Ireland and the Isle of Man)	900	900
Private stairs (Scotland)	840	900
Common stairs	900	1100

## FIRE PRECAUTIONS

### 6.6 - D9 Staircases shall provide the necessary means of escape in case of fire

Timber staircases are acceptable within a single family dwelling where there are no more than four storeys, excluding the basement.

Houses of three or more storeys and flats in buildings of three or more storeys

should comply with the relevant Building Regulations.

Ventilation of staircases serving flats in buildings of three or more storeys should comply with BS 5588.

## LIGHTING

### 6.6 - D10 Lighting shall be provided to ensure safe use of the staircase

Artificial light sources should be provided to all staircases and landings. Within dwellings, lighting to stairs should be controlled by two way switching.

Where the Public Lighting Authority specify and maintain control of entrance lighting, their requirements should be met. Otherwise, landings and staircases in common areas to dwellings should be provided with adequate artificial lighting. Manual two way switching, controlled by people using these areas is acceptable. Automatic light sensitive controls may be used, provided lights can also be switched two way manually.

Reference should be made to Chapter 8.1 'Internal services' (Design) for further details on lighting.

Where staircases are lit by glazing, any glass below the minimum height of guarding (see Table to Clause D8(b)) should be:

- protected by a balustrade or railing, or
- glass (toughened or laminated), or
- constructed of glass blocks.

## PROVISION OF INFORMATION

### 6.6 - D11 Designs and specifications shall be produced in a clearly understandable format and include all relevant information

Usually, staircase drawings and specifications should show:

- layout of stairs
- dimensions covering width, rise and going, handrail height, etc
- fixings of stairs, treads, risers, strings, balustrades, newel posts and handrails, as appropriate
- the length of time before formwork can be removed from in-situ concrete stairs
- whether precast concrete or steel staircases can be used immediately after erection or whether time should be allowed to cure grouted connections.

### 6.6 - D12 All relevant information shall be distributed to appropriate personnel

Ensure that design and specification information is issued to site supervisors and relevant specialist subcontractors and/or suppliers.



## MATERIALS STANDARDS

### 6.6 - M1 All materials shall:

- (a) meet with Technical Requirements
- (b) take account of the design

Materials that comply with the design and the guidance below will be acceptable for staircases.

Materials for staircases should comply with all relevant standards, including those listed below. Where no standard exists, Technical Requirement R3 applies (see Chapter 1.1 'Introduction to the Standards and Technical Requirements').

References to British Standards and Codes of Practice include those made under the Construction Products Directive (89/106/EEC) and, in particular, appropriate European Technical Specifications approved by a European Committee for Standardisation (CEN).

## STAIRCASE UNITS

### 6.6 - M2 Proprietary staircases and associated components shall comply with the design and Technical Requirements

Where proprietary staircases or associated components are proposed, they should meet the statutory and design requirements for stairs, as detailed in the drawings and/or specification.

Manufacturers of staircases and balustrading, etc should be sent all relevant drawings and other information to ensure their products meet the design requirements.

Allowance should be made for tolerances or actual site dimensions.

## TIMBER AND WOOD-BASED PRODUCTS

### 6.6 - M3 Timber and wood-based materials shall be of sufficient quality and durability for use in staircases

Items to be taken into account include:

#### (a) timber

Timber for joinery should:

- comply with BS 1186 : Part 1
- be Class 3 or better, and
- be free of resinous knots, splits, shakes and waness.

Fits of joints, construction of joints, moving parts, glueing, laminating, construction of finger joints and surface finish should be to BS 1186 : Part 2.

Timber which is to be exposed to the weather should be suitably durable or be pre-treated with preservative against fungal attack in accordance with Chapter 2.3 'Timber preservation (natural solid timber)'.

#### (b) plywood

Plywood should be used only for risers and should comply with BS EN 636.

#### (c) chipboard

Chipboard should comply with Type P5 of BS EN 312.

#### (d) oriented strand board

Oriented strand board should comply with Type OSB3 of BS EN 300.

#### (e) medium density fibreboard

Fibre building boards should comply with BS 1142 : Part 2.

#### (f) laminated timber

Glued laminated timber structural members should comply with BS 4169.

## IN-SITU AND PRECAST CONCRETE

### 6.6 - M4 Concrete shall be of the mix proportions to achieve adequate strength as required by the design

Reference should be made to Chapter 2.1 'Concrete and its reinforcement' (Design and Materials) for guidance on concrete, reinforcement and additives.

## FIXINGS

### 6.6 - M5 Fixings shall be of adequate strength and durability and comply with the design

Fixings should be checked for compliance with the design and whether they are provided by the supplier, especially for:

- timber and steel staircases
- newel posts
- handrails
- guarding and balustrading.

## SITWORK STANDARDS

### 6.6 - S1 All sitework shall:

- (a) meet the Technical Requirements
- (b) take account of the design
- (c) follow established good practice and workmanship

Construction that follows the design and the guidance below will be acceptable for staircases.

## LOCATION AND FIXING

### 6.6 - S2 Staircases shall be correctly located and fixed

Items to be taken into account include:

#### (a) headroom

The overall floor opening should be checked for size to accept the stairs and to allow sufficient headroom.

The minimum headroom above stairs should be measured vertically from the pitch line. The clear headroom (**h**) over

the entire length and width of a stairway, including landings, should be 2.0m.

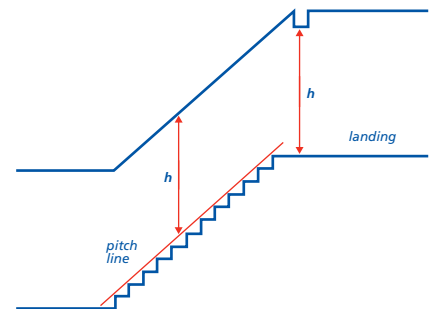

#### (b) overall vertical rise

Staircases are normally manufactured off site so the floor-to-floor dimensions should be accurate. An allowance should be made for floor finishes to structural floors or staircase treads.

#### (c) pitch

Staircases should be accurately located and fixed with the string at the correct angle so all treads are horizontal.

#### (d) landings

Landings, where required, should be properly framed to provide full support to and secure fixings for flights, nosings, newels, apron linings, etc.

#### (e) floor finishes

Allowance should be made for stair and floor finishes to ensure that all risers are equal.

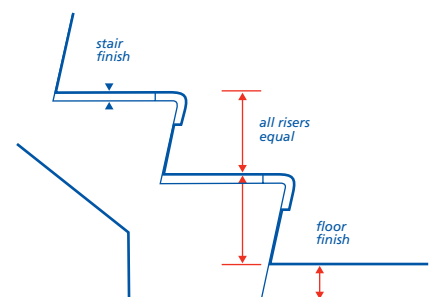

## TIMBER STAIRCASES

### 6.6 - S3 Timber staircases shall:

- (a) have secure component parts, including strings, treads and risers, newel posts, balusters and handrails
- (b) be securely fixed to the supporting structure

Strings should be glued to newel posts and secured with dowels or screws. Particular attention should be given to winders; remedying problems, such as deflection and/or squeaking, can be difficult, especially if the soffit covering has been fixed.

Landings should be framed to provide full support and solid fixings for the tops of flights, nosings, newels, apron linings, etc.

# 6.6 Staircases

Newel posts should be plumb and fixed securely.

The top nosing should be level with the floor decking and should be fixed firmly.

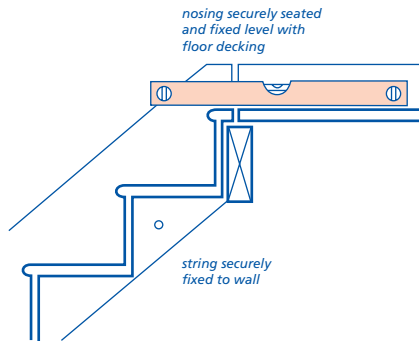

## 6.6 - S4 Finished joinery shall be free from unsightly blemishes

Finished joinery should be free from splits, knocks and other damage which would impair its structural performance or finish.

Handrails should have a smooth finish, free from rough edges. No handrail bracket or screw head should present a sharp edge.

Nails should be punched below the surface of the wood and stopped.

## CONCRETE STAIRCASES

### 6.6 - S5 The structure shall be set out and constructed to ensure that staircases are correctly located and levelled

#### PRECAST CONSTRUCTION

When setting out levels, account should be taken of the thickness of finishes to the floor or landing, as well as any finish to be applied to the stair treads. Particular care is needed at the top and bottom of each flight.

Precast units should be accurately located and levelled.

#### IN-SITU CONSTRUCTION

Shuttering for in-situ concrete elements or connections should be accurately constructed to ensure a consistent rise and going.

#### FLOOR FINISHES

For both precast and in-situ staircases, allowance should be made for the thickness of finish at the top and bottom of flights.

### 6.6 - S6 Concrete staircases shall be constructed to provide satisfactory final performance

Items to be taken into account include:

#### (a) correct placing of reinforcement to give the required cover

Chairs or spacing blocks should be used to give the following minimum cover to reinforcement:

	Minimum cover [mm]
Internal staircases	25
Staircases open to the weather	50

#### (b) allowance for nosings and any cast-in finishes

Allowance should be made for pre-formed nosings or non-slip finishes, if specified (see also Clause S5).

#### (c) correct striking of formwork

Formwork should be struck in accordance with the design, normally:

- side formwork - after 24 hours
- soffit and support formwork - after 28 days.

### 6.6 - S7 Appropriate measures shall be taken when concreting in cold weather

Reference should be made to Chapter 1.4 'Cold weather working' when concrete, mortar, grout or other materials containing water are used.

## STEEL STAIRCASES

### 6.6 - S8 The supporting structure shall be accurately set out to receive steel staircases

The supporting structure should be constructed within the tolerance limits set for the steel staircase. Treads should be checked for level. The correct fixings should be available.

### 6.6 - S9 All work shall be carried out strictly in accordance with manufacturers' instructions

Manufacturers' assembly and erection instructions should be available and followed.

## HANDRAILS AND BALUSTRADES

### 6.6 - S10 A handrail shall be correctly located and fixed to provide a safe handhold

A handrail should be provided for any flight that rises 600mm or more. The handrail should be fixed between 900mm (840mm in Scotland) and 1000mm vertically above the pitch line.

The ends of the handrail should be shaped or returned to the wall to prevent clothes catching on projections.

Throughout its whole length the handrail should be:

- fixed securely
- continuous
- smooth and unobstructed
- at least 25mm from any surface.

Check that fixing and location are in accordance with the design.

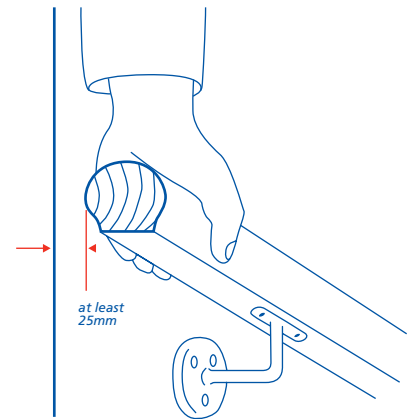

### 6.6 - S11 Balustrading shall be securely fixed and constructed to reduce the risk of it being climbed up or fallen through

Statutory regulations require that balustrading:

- is fixed securely
- cannot be easily climbed, and
- has no gaps which would allow a 100mm diameter sphere to pass through.

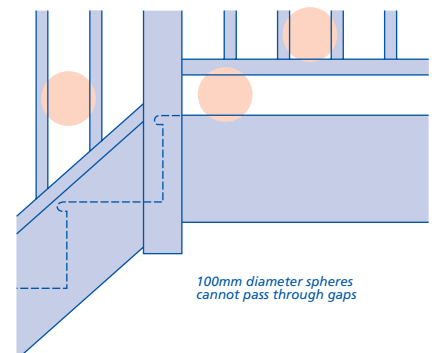

In concrete staircases, balustrading may be:

- grouted into pre-formed holes or pockets
- bolted or screwed into pre-drilled holes
- bolted to brackets cast into the concrete.

Fixing methods for balustrading should allow a degree of tolerance. It may be preferable to take measurements from the completed staircase, whether of in-situ or precast construction, before manufacturing the balustrading. This will ensure that the fixings are positioned correctly and allow for variations in the surrounding structure.

Design details on the spacing of bolt fixings for balustrades or handrails should be followed.

Care should be taken when using expanding fixings near the edges of concrete (whether in-situ or precast).

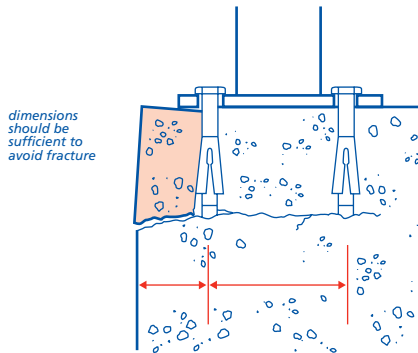

## PROTECTION OF FINISHED WORK

**6.6 - S12 On completion, staircases shall be undamaged, fixed properly and suitable for handover**

When stored, staircases should be stacked on bearers. Wood staircases should be stored under cover and be fixed in place only when the building is weathertight.

Staircases, stair treads, nosings, balustrades and handrails may be protected with timber strips, plywood or building paper. Plastic sheeting should not be used to protect stairs because it gives a slippery surface which is not safe to walk on.

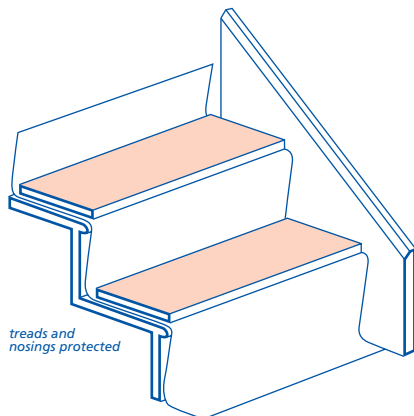

# 6.6 Staircases

## APPENDIX 6.6-A

### Design aid for rise and going

Rise and going which intersect within the relevant shaded areas meet the criteria  $2R+G$  between 550mm and 700mm.

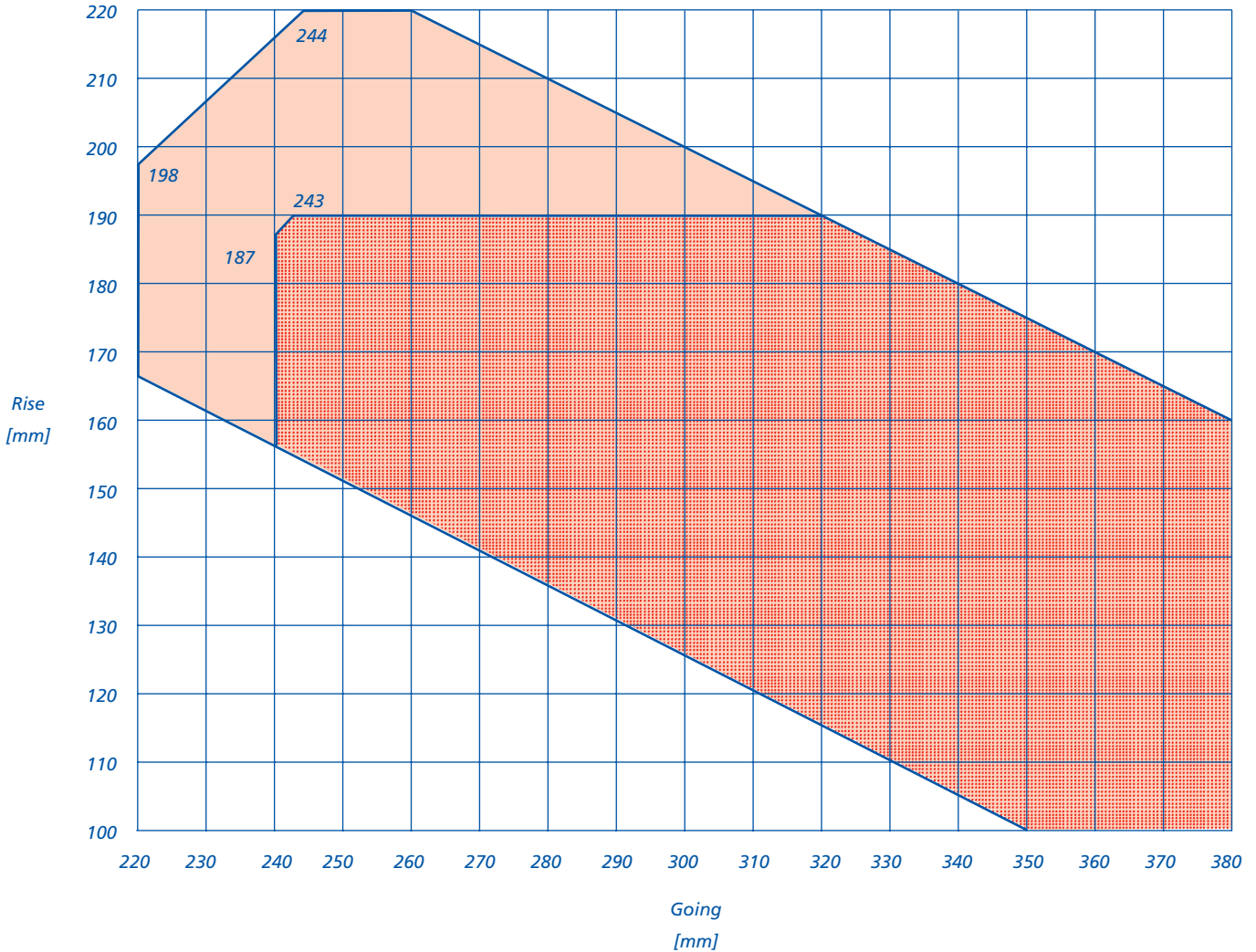

#### Key

Private stairs - whole of shaded area

Common stairs - hatched area only

Based on Figure 11 in BS 5395 : Part 1.

**INDEX**

<b>B</b>		<b>I</b>		<b>R</b>	
Balusters	3, 4, 5	In-situ concrete	3, 4	Reinforcement	4
<b>C</b>		<b>J</b>		Rise	1, 3, 6
Chipboard	3	Joinery	4	<b>S</b>	
Concrete	3	<b>L</b>		Steel staircases	1, 4
Concrete staircases	1, 4, 5	Landings	1, 2, 3	Steps	1
<b>D</b>		Lighting	2	Straight flights	1
Differential movement	1	Location	3	Strings	3
Doors	2	<b>M</b>		<b>T</b>	
Durability	3	Means of escape	2	Timber	3
<b>F</b>		Medium density fibreboard	3	Timber staircases	1, 3
Finish	4	Movement	1	Treads	1, 3, 4
Fire precautions	2	<b>N</b>		<b>W</b>	
Fixings	1, 3, 4, 5	Nosings	3, 4, 5	Width	1, 3
Floor finishes	3, 4	Newel posts	3	Winders	1
Formwork	4	<b>O</b>			
<b>G</b>		Oriented strand board	3		
Going	1, 6	<b>P</b>			
Guarding	2	Pitch	1, 3		
<b>H</b>		Plywood	3		
Handrails	2, 3, 4	Precast concrete	3, 4		
Headroom	1, 3	Proprietary staircases	1, 3		
		Protection	5		



# Chapter 6.7

## Doors, windows and glazing

---





# 6.7 Doors, windows and glazing

## CONTENTS

	Clause	Page
<b>DESIGN</b>		
Design standards	D1	1
Statutory requirements	D2	1
Environmental factors	D3	1
Security	D4	1
Inservice performance	D5	2
Resistance to decay	D6	2
Glazing	D7	2
Provision of information	D8	3
<b>MATERIALS</b>		
Materials standards	M1	3
Timber doors and windows	M2-M4	3
Non-timber doors and windows	M5	3
Ironmongery	M6	3
Glazing	M7	4
<b>SITWORK</b>		
Sitework standards	S1	4
Protection against damp	S2	4
Location and fixing	S3	4
Glazing	S4-S5	5
Protection	S6	6
<b>INDEX</b>		6

## SCOPE

This Chapter gives guidance on meeting the Technical Requirements and recommendations for doors, windows and glazing, including where coupled door and window frame assemblies are contained within a single storey.

Coupled door and window frame assemblies which are:

- one storey or more in height, or
- not contained between a structural floor and ceiling

should be designed in accordance with Chapter 6.9 'Curtain walling and cladding'.

## DESIGN STANDARDS

### 6.7 - D1 Design shall meet the Technical Requirements

Design that follows the guidance below will be acceptable for doors, windows, and glazing.

## STATUTORY REQUIREMENTS

### 6.7 - D2 Design shall comply with all statutory requirements

Design should be in accordance with relevant Building Regulations and other statutory requirements.

## ENVIRONMENTAL FACTORS

### 6.7 - D3 Design and selection of doors, windows and glazing shall take account of location and planning requirements

Items to be taken into account include:

#### (a) noise control

Where noise levels are very high, for example near airports or motorways, it may be advisable to install sound-insulating windows, usually of special design and construction.

#### (b) planning requirements

Local planning authorities may impose limitations on the shape, size and choice of materials for windows and doors, for example in conservation areas.

#### (c) climatic conditions

Climatic conditions, especially wind speed, together with the required level of window performance (eg in relation to air tightness), may govern the size of glass panes and opening lights in exposed locations.

## SECURITY

### 6.7 - D4 Doors, door frames, windows and locks shall be designed and specified so as to improve their resistance to unauthorised entry

Items to be taken into account include:

#### (a) locks to main entrance doors of dwellings (including houses, flats and maisonettes)

##### DWELLINGS - all

All entrance doors of individual dwellings should be fitted with one (or more) securely fixed lock and keep or multi-point locking system, which has:

- at least 1000 differs, and
- a fixing which, if burst open, would not pull out without breaking the door or its frame, and
- a hardened steel bolt or inserts to prevent sawing, and
- latch and deadlocking facility.

Locking devices fitted to entrance doors should permit emergency egress without the use of a key when the dwelling is occupied. Any glazing which, if open or

broken, would permit release of the snib by hand or arm entry should be laminated.

#### DWELLINGS - with an alternative means of escape via a door

Lock(s) should provide initial security by use of a latch operable with a key externally and a handle/thumb turn release internally. The full deadlocking facility should be engaged and be operable with a key externally and a handle/thumb turn release internally. Locks which comply with BS 8621, meet these requirements. External handles on multi-point locking systems should be twin or split spindle to avoid operating the latch.

Enhanced security can also be achieved by providing the facility to deadlock the internal/thumb turn when leaving the dwelling un-occupied. Locks which comply with BS 10621, meet these requirements.

#### DWELLINGS - opening direct to outside without an alternative means of escape via a door

The door should be held closed by use of a latch operable with a key externally and a handle/thumb turn release internally. The full deadlocking facility should be engaged and be operable with a key externally and a handle/thumb turn release internally. Locks which comply with BS 8621, meet these requirements. External handles on multi-point locking systems should be twin or split spindle to avoid operating the latch.

#### DWELLINGS - opening onto a communal access without an alternative means of escape

The door should be held closed either on a latch operable with a handle both internally and externally or a roller bolt so that the door cannot slam shut locking the homeowner out without a key. The full deadlocking facility should be engaged and be operable with a key externally and a handle/thumb turn release internally. Locks which comply with BS 8621, meet these requirements.

Timber or light steel frame walls, should incorporate one of the following:

- timber sheathing minimum 9mm thick, or
- expanded metal.

The material should be the full height of the door and not less than 600mm measured from the lock(s).

#### (b) opening limitation devices to main entrance doors

A securely fixed opening limitation device should be fitted to main entrance doors in houses and the entrance doors of individual flats and maisonettes.

In sheltered accommodation opening limitation devices should be not inhibit emergency access. Alternative methods for residents to identify and communicate

with visitors, without opening their door, should be considered in place of opening limitation devices.

#### (c) view outside main entrance door

There should be a means of giving a wide angle view of the area immediately outside the main entrance door of individual dwellings. Acceptable ways include:

- a through-door viewer
- clear glazing either to part of the door or a convenient window
- closed circuit camera and display, which is not linked to television sets.

#### (d) secondary external access doors

The door should be held closed on a latch and operable by use of a handle both internally and externally. A deadlocking facility should be operable by use of a key both internally and externally. Locks complying with BS 3621 meet these requirements. Alternatively a thumb turn may be used internally in place of key operation. Locks complying to BS 8621 meet these requirements.

In addition bolts should be fixed securely at both top and bottom of the door on the internal opening edge.

Where multi-point locking systems are used bolts may be omitted.

External sliding doors should be secured by way of multi-point locking system with a minimum of three locking points incorporating mushroom headed bolts, hookbolts or shoot bolts. Where shoot bolts are fitted they should engage into the head and sill of the door frame. An anti-lift device should also be fitted so that doors cannot be lifted from their frame from the outside.

Connections between door and/or frame components which can be easily released from outside should not be used. This includes accessible screw connections.

#### (e) fittings for windows

Ironmongery for windows should be supplied as follows:

- hinges and fastenings of opening lights of windows should be of a type which prevents them from being opened from the outside when in the closed position
- opening lights on all ground floor windows and others which are readily accessible from the outside may be fitted with lockable devices which cannot be released without a key
- where the windows are required by Building Regulations to have background ventilation they may be fitted with trickle ventilators or some other means of providing ventilation which is controllable and located to avoid undue draughts. Windows with 'night vent' positions are not accepted as meeting these recommendations.

# 6.7 Doors, windows and glazing

## IN SERVICE PERFORMANCE

### 6.7 - D5 Doors, windows and glazing shall be designed and specified to ensure adequate performance in service

Items to be taken into account include:

#### (a) weather resistance

Windows and external doors exposed to wind-driven rain may need particular protection to ensure they remain weathertight.

BS 6375 contains recommendations for the classification of window components according to their resistance (under test to air and water penetration, and wind pressure). A similar classification is used by BBA for certification of windows.

Water penetration may occur not only between frame and opening leaf or light, but also between the frame and the surrounding structure. Vertical and horizontal dpcs should be provided around the frame in accordance with Chapter 6.1 'External masonry walls' (Design and Sitework).

In Scotland, Northern Ireland and other locations of Very Severe exposure, rebated reveal construction should be sealed with an appropriate sealant.

Reference should be made to Chapter 6.1 'External Masonry Walls' Appendix 6.1-A for categories of exposure to wind driven rain.

In all locations where weathertightness is likely to be a problem, additional precautions may be needed, such as:

- setting the frame back from the facade
- fixing the frame behind a rebate in the structural opening (sometimes known as a 'check' reveal)
- fixing weather boards and water bars to external doors but ensuring threshold is accessible where appropriate

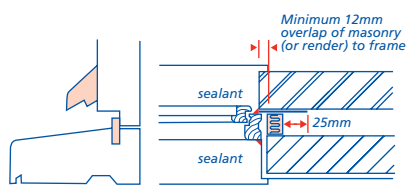

water bar and weatherboard provided for external doors 'rebated' or 'check' reveal in areas of Very Severe exposure

- building a projecting porch
- rain check grooves to inward opening external door frames
- a combination of the above.

Joists between multiple frames should be engineered as part of the manufacturer's system to ensure satisfactory in-service performance.

Coupled door and window frame assemblies one storey or more in height or not contained between a structural floor and ceiling, should be designed in accordance with Chapter 6.9 'Curtain walling and cladding'.

#### (b) thermal break

Where metal windows are to be used, designs should incorporate a thermal break.

#### (c) ventilation control

Trickle ventilation is covered in Clause D4.

Mechanical ventilation is covered in Chapter 8.1 'Internal services' (Design).

#### (d) fire safety

Fire resisting doors and positive self-closing devices should be fitted where required by Building Regulations.

#### (e) strength

Door frames and windows and their fittings should be adequate to withstand operational loads. Structural loads should be carried on lintels, beams or some other structural element. If frames are required to carry structural loads, they should be designed accordingly.

#### (f) resistance to movement, shrinkage and the effects of moisture

Doors and windows should be designed and selected to avoid significant distortion, such as twisting and bowing during use. Timber shrinkage should be allowed for.

To reduce twisting, doors should be hung on hinges as follows:

Type of door	Hinges
External	1½ pairs x 100mm
Fire door	1½ pairs* x 100mm
Airing or cylinder cupboard	1½ pairs x 75mm
Other internal	1 pair x 75mm

\* 1 pair where rising butts are used

Window boards may be wetted by condensation. Materials other than natural timber should be moisture-resistant.

#### (g) emergency access

Where doors to rooms containing a bath or WC have a securing device, it should be of a type capable of being opened from the outside in an emergency.

In sheltered accommodation, additional special provisions may be needed for all door locks, limiters and other fasteners, to enable wardens to gain access to dwellings when necessary.

## RESISTANCE TO DECAY

### 6.7 - D6 Joinery for external doors and windows shall be adequately protected against decay

The following elements of timber doors and windows should be of naturally durable timber or timber pre-treated against fungal decay:

- external door frames
- windows
- timber surrounds to metal windows
- external doors, other than flush doors.

For detailed information, reference should be made to Chapter 2.3 'Timber preservation (natural solid timber)' (each section).

## GLAZING

### 6.7 - D7 Glass and the method of glazing shall be selected to:

#### (a) resist wind loads

The quality and thickness of normal window glass should be specified to suit the design wind load for the location, in accordance with BS 6262 and relevant data sheets issued by the Glass and Glazing Federation.

#### (b) minimise risk of injury

Where there is a high risk of accidental breakage, the glazing should be designed and selected to comply with the safety recommendations for risk areas specified in Approved Document N for England, Wales and the Isle of Man, Technical Booklet V in Northern Ireland and BS 6262 in Scotland. Where there is a particular risk, such as at door side panels, 'low level' glazing and where fully glazed panels can be mistaken for doors, toughened or laminated glass, or other materials, such as acrylic or polycarbonate, may be needed.

#### (c) ensure adequate performance

##### DRAINED AND VENTED SYSTEMS

- These systems should allow any moisture that enters the glazing channel between the frame and the edge seal of the insulating glass unit to be drained away. The system should prevent long term moisture contact with the edge seal.

A gap of at least 5mm should be provided between the frame's lower rebate and the edge seal of the insulating glass unit. Adequate drainage and ventilation should be provided by holes, slots or channels.

Insulating glass units 1m<sup>2</sup> or greater in area should have a drained and vented glazing system, whether they are factory glazed or site glazed.

Suitable systems and installations are shown in the relevant parts of BS 8000, BS 6262 and BRE Digest 453. The system should provide adequate protection of the edge seal of the insulating glass unit.

##### FULLY BEDDED SYSTEMS

- Factory glazed methods should be in accordance with the relevant parts of BS 8000, BS 6262 and BRE Digest 453.

Fully bedded systems (acceptable for factory glazing only) rely on no gaps being left around the perimeter of the insulating glass units. Moisture that can reach these areas will lead to the

breakdown of the edge seal.

Site glazing may incorporate fully bedded systems on the top and sides of the insulating glass unit but the rebate platform requires a drained and vented bottom bead.

#### INSULATING GLASS UNITS

- Insulating glass units should comply with the requirements of BS EN 1279, be CE marked and the subject of a third party certification scheme (e.g. Kitemarking).

Insulating glass units should normally have a dual seal, or single seal if of hot melt butyl, together with desiccant in at least one long and one short section of the spacer bar.

#### BEADS

In external situations the bottom bead should project slightly over the rebate edge, and be bedded to the rebate platform.

## PROVISION OF INFORMATION

### 6.7 - D8 All relevant information shall be distributed to appropriate personnel

Ensure that design and specification information is issued to site supervisors and relevant specialist subcontractors and/or suppliers.

## MATERIALS STANDARDS

### 6.7 - M1 All materials shall:

- (a) meet the Technical Requirements
- (b) take account of the design

Materials that comply with the design and the guidance below will be acceptable for doors, windows and glazing.

[Joints between door and window frame assemblies should be formed with suitable materials to ensure durability and satisfactory in-service performance.](#)

Materials for doors, windows and glazing should comply with all relevant standards, including those listed below. Where no standard exists, Technical Requirement R3 applies (see Chapter 1.1 'Introduction to the Standards and Technical Requirements').

References to British Standards and Codes of Practice include those made under the Construction Products Directive (89/106/EEC) and, in particular, appropriate European Technical Specifications approved by a European Committee for Standardisation (CEN).

## TIMBER DOORS AND WINDOWS

### 6.7 - M2 Timber and wood-based materials shall be of the quality and dimensions required by the design

Items to be taken into account include:

#### (a) classification and use

All timber and wood-based materials should comply with the relevant requirements of BS EN 942 as follows:

- glazing beads - European
- window casements/sashes - 'J' classes
- all other elements - (see table 1 of BS EN 942).

In England, Wales, Northern Ireland and the Isle of Man, planted stops are not permitted on frames to external doors.

Storey-height frames should be of a section appropriate to their height and function.

External doors should be not less than 42.5mm (44mm nominal) in thickness.

Wood windows should comply with the relevant requirements of BS 644 and have a minimum rebate depth of 15mm where double glazed units are to be installed.

Medium density fibreboard for window boards should be moisture resistant grade.

#### (b) drying shrinkage

To minimise drying shrinkage, the moisture content of joinery, when fixed, should not exceed the following:

Joinery items	Moisture content (%)*
Windows and frames	17
Internal joinery in:	
- intermittent heating	15
- continuous heating	12
- in close proximity to a heat source	9
* on delivery, the moisture content should be within 2% either side of the values specified.	

#### (c) workmanship

All prefabricated items should be constructed to a good standard of workmanship, including:

- fit and construction of joints
- construction of finger joints
- glueing and laminating
- construction of moving parts
- surface finishes.

Prefabricated components should comply with the relevant parts of BS 1186 : Part 2.

#### (d) surface finish

Any surface finishing defects should be such that they would not be apparent with a matt paint finish, whether the surface is to be stained or painted, gloss or matt.

### 6.7 - M3 Timber for doors and windows shall be of a naturally durable timber species or preservative treated and primed

Items to be taken into account include:

#### (a) preservation

Non-durable timbers used externally should be treated, see Chapter 2.3 'Timber preservation (natural solid timber)' (each section) for details.

Preservative treatment is required for the following:

- external door frames
- windows
- timber surrounds to metal windows
- external doors, other than flush doors.

#### (b) priming

Material to be painted should be primed before fixing. For further guidance on preparing elements for painting, see Chapter 8.5 'Painting and decorating' (each section).

#### (c) staining

Material to be stained should have the first coat applied before delivery to site.

### 6.7 - M4 Glazing compounds and timber stains shall be compatible

Compatibility of glazing, sealants and finishes should be checked with relevant manufacturers.

## NON-TIMBER DOORS AND WINDOWS

### 6.7 - M5 Doors and windows of materials other than timber shall be in accordance with appropriate standards

Relevant standards include the following:

BS 4873	Specification for aluminium alloy windows
BS 6510	Specification for steel windows, window boards and doors
BS 7412	Plastics windows made from PVC-U extruded hollow profiles
BS 7413	White PVC-U extruded hollow profiles with heat welded corner joints for plastics windows: materials type A
BS 7414	White PVC-U extruded hollow profiles with heat welded corner joints for plastics windows: materials type B.

Third party certification is also required for PVC-U windows. Windows which are Kitemarked will meet with the Performance Standard.

Doors and windows to which the above British Standards do not apply should have been assessed in accordance with Technical Requirement R3.

## IRONMONGERY

### 6.7 - M6 Ironmongery shall be of the type and material required by the design

Items to be taken into account include:

#### (a) relevant standards

Ironmongery should be provided in accordance with the design and specification. For critical functions, materials should comply with appropriate standards, including the following:

# 6.7 Doors, windows and glazing

BS EN 1935	Building hardware - single axis hinges - Requirements and test methods
BS 3621	Thief resistant lock assembly. Key egress
BS 8621	Thief resistant lock assembly. Keyless egress
BS 10621	Thief resistant dual mode lock assembly
BS 4951	Specification for builders' hardware: lock and latch furniture (doors)
BS 5872	Specification for locks and latches for doors in buildings
BS 6459	Door closers.

## (b) security

Security items for doors and windows are contained in Clause D4.

## (c) door hinges

The requirements for door hinges are contained in Clause D5(f).

## GLAZING

### 6.7 - M7 Glazing shall be as required by the design

#### (a) relevant standards

Insulating glass units and glazing materials should comply with appropriate British Standards, including the following:

BS 5516	Code of Practice for patent glazing
BS 6262	Code of Practice for glazing of buildings
BS EN 1279	Glass in buildings - insulating glass units.

#### (b) materials

Glazing components should be compatible with the frame finishes. Manufacturers' recommendations should be taken into account. Materials from different manufacturers should not be used together unless both have agreed in writing.

Linseed oil based putty should never be used for the installation of laminated glass or insulating glass units.

#### (c) glass

Glass used in insulating glass units for windows and doors should comply with appropriate British Standards including the following:

- Annealed glass - BS EN 572
- Laminated glass - BS EN 14449
- Toughened glass - BS EN 12150
- Wired glass - BS EN 572
- Low-e coated glasses, including both hard and soft coated - BS EN 1096.

#### (d) safety and security

The glass supplier should provide documentation to confirm the properties of the various glasses used and conformance with the appropriate British Standards.

Permanent marking of safety glass (including glazed shower/bath screens) is required.

Glazing materials should be compatible with the required levels of safety and security. The requirements for critical locations with a high risk of accidental breakage should comply with the safety requirements of Approved Document N in England, Wales and the Isle of Man, Technical Booklet V in Northern Ireland and BS 6262 in Scotland.

## SITWORK STANDARDS

### 6.7 - S1 All sitework shall:

- (a) meet the Technical Requirements
- (b) take account of the design
- (c) follow established good practice and workmanship

Sitework that complies with the design and the guidance below will be acceptable for doors, windows and glazing.

## PROTECTION AGAINST DAMP

### 6.7 - S2 Door and window components shall, where necessary, be adequately protected against damp

Items to be taken into account include:

#### (a) priming

Material to be painted should be primed before fixing. Material to be stained should have the first coat applied before delivery to site. Any material delivered untreated should be treated promptly.

Neither primer nor the first coat prevent joinery from taking in moisture.

#### (b) storage

When joinery is stored on site, precautions should include:

- avoiding wetting during unloading
- stacking external joinery on bearers off the ground and covering with waterproof material
- storing internal joinery in a weather-protected condition.

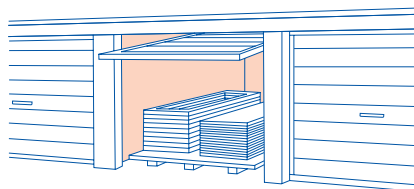

Joinery which is not properly stored or protected may not meet Technical Requirement R3.

## LOCATION AND FIXING

### 6.7 - S3 Doors and windows shall be correctly located and securely fixed

Items to be taken into account include:

#### (a) weathertightness

Doors and windows should be installed correctly so they perform satisfactorily in use.

Dpcs should be correctly installed.

The dpc should extend approximately 25mm into the cavity. If a thick block is used to close the cavity and form the reveal, a wider dpc will be required.

Vertical dpcs should extend continuously to the full height of the frame.

In Scotland, Northern Ireland and areas of Very Severe exposure in England, Wales and the Isle of Man, 'check' reveals should be used. Additionally, an appropriate sealant is required between doors and windows and masonry.

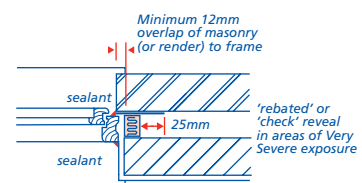

Joists between multiple door and window frame assemblies should be part of an engineered system and formed using suitable materials in accordance with the manufacturer's recommendations.

#### (b) fixing

Window frames and linings should be fixed solidly, level and plumb and should be either:

- secured by door/window cramps, or
- plugged and screwed.

Fixings should be not more than 600mm apart and not more than 150mm from top or bottom. Alternative locations and fixings are acceptable as long as they provide the same structural stability.

When driving wedges or other fixings, frames or other components should not be distorted.

Frames and linings should fit tightly into openings and be blocked or packed out at fixing points, where necessary.

Frames for external elements should be located in openings so that the head of the frame is protected by the lintel, and throatings in sill members are not obstructed by the wall face.

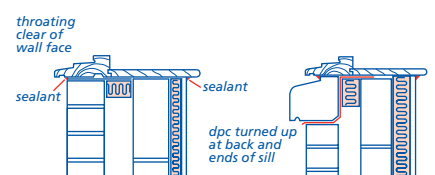

In Scotland, Northern Ireland and areas of Very Severe exposure in England, Wales and the Isle of Man, it is not acceptable to fix window frames in the outer leaf of external walls.



### (c) bay windows

To prevent sagging and bowing, bay and bow type windows should be adequately supported and secured to the structure to prevent casements becoming twisted.

Bay windows should be properly linked to dpcs at reveals.

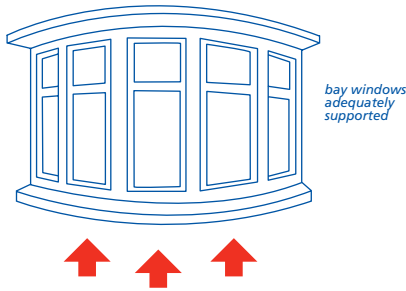

### (d) cut ends

Where pre-treated joinery is cut or adjusted on site, the affected surfaces should be re-treated with two flood brush coats of appropriate preservative.

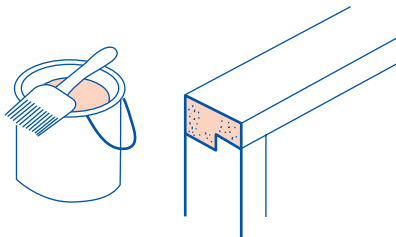

### (e) window boards

The top surface of window boards should be flat and level. Boards should be fixed close to the frame and adequately secured against twist and other movement, particularly any back slope towards the frame.

Medium density fibreboard should be moisture resistant grade.

### (f) hanging doors and opening lights

Opening lights and door leaves should hang square within the frame or lining and fit neatly with minimum gaps, subject to the requirements of effective weatherstripping. Doors to bathrooms and WCs with mechanical ventilation should be hung with a gap at the bottom or be fitted with a ventilation grille.

Where a standard flush door is reduced in height, the bottom rail should be replaced if necessary. The leading edges of doors should be protected with timber lipping, where necessary.

### (g) general ironmongery

Where required, hinges and other ironmongery should be housed neatly flush with the surface.

The full complement of matching screws should be provided and properly screwed home.

Locks should not be fitted in mortices too tightly and keyholes should be aligned and locks should turn easily. The clearance between a door handle and a door stop should be at least 25mm.

### (h) door hinges

To reduce twisting, doors should be hung on hinges as follows:

Type of door	Hinges
External	1½ pairs x 100mm
Fire door	1½ pairs* x 100mm
Airing or cylinder cupboard	1½ pairs x 75mm
Other internal	1 pair x 75mm

\* 1 pair where rising butts are used

### (i) security

Security items for doors and windows are contained in Clause D4.

### (j) workmanship

Internal door frames and linings should be of the correct widths to match the wall or partition thickness, including finish.

Frames and linings should be blocked off walls, wherever possible, to allow for full architraves.

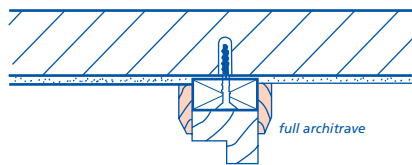

All timber trim should be:

- sufficiently wide to mask joints, and
- fixed so as to minimise movement and shrinkage.

Architraves should be:

- parallel to frame and lining arrises
- accurately mitred or scribed to fit tightly and neatly
- fixed with an equal margin to each frame member
- fixed securely together with linings to prevent curling.

Nails should be punched below the surface of the timber and holes stopped. Nails should not be driven home with the hammer head. Damage should be avoided where easing is necessary. Any damage should be made good.

### (k) finish upon completion of work

Work should be left in a clean state and brought to an appropriate level of finish for other trades.

Finishing trades should not be relied upon to correct untidy work.

## GLAZING

**6.7 - S4 Glass and glazing shall be installed upon delivery or shall be adequately stored and protected until required**

Glass and insulating glass units should be inspected for visual defects and defects which could lead to premature failure.

Often, defects are caused by:

- water accumulating between sheets, which may cause surfaces to become marked, and
- edge damage or scratching.

**6.7 - S5 Glazing shall be carried out in accordance with relevant standards**

Items to be taken into account include:

### (a) size of insulating glass units/sheets

Sufficient space should be provided between the glass edge and the frame to allow for thermal expansion of the glass. A gap of 3mm is recommended, except for drained systems where at least 5mm is required for drainage at the bottom bead. Insulating glass units should not be cut or punctured in any way on site.

When cutting single sheets of glass or plastics for windows, an allowance should be made for thermal movement of the pane, taking into account:

- the material being used, and
- the size of the pane.

This allowance is especially important when window rebates are shallow, allowing limited tolerance for expansion of the glazing.

### (b) rebates

Before glazing, rebates should:

- have been primed (for timber frames),
- be rigid and true, and
- be of the correct size for the glazing.

Insulating glass units should be properly protected by the frame from sunlight. The spacer bar of the insulating glass unit should always be below the level of the frame's sightline.

Setting and location blocks should be of a suitable resilient material. In drained and ventilated frames the drainage channels in the rebate should be free from obstructions that prevent effective drainage. The dimensions of holes and slots should be checked to ensure that effective drainage can occur.

### (c) bead glazing

Beads and linings should be used for:

- all internal glazing
- other locations where shock absorption properties are required.

Beads should be used:

- where doors or windows are to be finished with water-borne stains

# 6.7 Doors, windows and glazing

- where fully bedded systems are used to install insulating glass units
- where glazing takes place on site, the bottom bead should be drained and vented.

Beads should be fixed at not more than 150mm centres.

## (d) glazing compounds

All materials should be compatible and used in accordance with the manufacturer's recommendations. Materials from different manufacturers should not be used together unless both have agreed in writing.

## (e) insulating glass units

Unless factory glazed, insulating glass units should be installed in accordance with the design. In timber frames where solid bedding methods are to be used on site, the bottom bead should be drained and vented.

Insulating glass units and any accompanying documentation should

be checked to ensure that they comply with the design. The insulating glass units should carry a CE mark to BS EN 1279 and have a third party assessment certificate such as the BSI Kitemark. The glass type, gas filling, edge seal type and dimensions should be checked against the documentation and the insulating glass unit itself.

## (f) doors and windows of materials other than wood

Where doors and windows of materials other than timber are delivered to the site unglazed, the glazing should be carried out in strict accordance with the manufacturer's instructions.

Appropriate fixing and sealing systems should include:

- distance pieces, unless load bearing tapes are used
- setting blocks
- location blocks where required
- appropriate beads
- glazing compounds, sealants, gaskets and/or capping.

## PROTECTION

### 6.7 - S6 Completed work shall be free from damage

Keep internal doors covered with polyethylene or original wrapping.

Door frames and linings should be protected with timber strips or plywood to at least 1m above skirting level. Thresholds and window sills should be covered. Scaffolding and walkways should be kept away from frames.

Joinery should be protected from paint splashes and other damage.

All temporary coverings should be removed after all other work has been completed, before handover.

## INDEX

<b>A</b>		<b>G</b>		<b>S</b>	
Aluminium doors and windows	3	Glazing	2, 3, 5	Secondary external access doors	1
<b>B</b>		Glazing compounds	5	Security	1, 3, 4
Bay windows	4	<b>I</b>		Steel doors and windows	3
<b>C</b>		Ironmongery	3, 4	Storage	4
Compatibility	3	<b>L</b>		Strength	2
<b>D</b>		Locks	1, 3	<b>T</b>	
Door hinges	2, 5	<b>M</b>		Timber doors and windows	3
Drained and vented systems	2	Main entrance doors	1	<b>V</b>	
Durability	2	<b>P</b>		Ventilation control	2
<b>E</b>		Performance	1, 2	<b>W</b>	
Emergency access	2	Preservation	2, 3, 4	Weather resistance	1
Environmental factors	1	Priming	3, 4	Weathertightness	1, 4
Escape windows	1	Protection	4, 5	Wind loads	2
<b>F</b>		PVC-U doors and windows	3	Workmanship	3, 4
Finish	5	<b>R</b>			
Fire safety	2	Rebates	5		
Fixing	4				
Flats and maisonettes	1				
Fully bedded systems	2				



# Chapter 6.8

Fireplaces, chimneys and flues

---



# 6.8 Fireplaces, chimneys and flues

## CONTENTS

<b>DESIGN</b>	Clause	Page
Design standards	D1	1
Statutory requirements	D2	1
General considerations	D3	1
Fireplaces and hearths (solid fuel)	D4	1
Walls near appliances (solid fuel)	D5	1
Flue pipes (solid fuel)	D6	1
Chimneys and flues (solid fuel)	D7	2
Chimney terminals (solid fuel)	D8	2
Fireplaces and hearths (gas)	D9	3
Flue pipes (gas)	D10	3
Chimneys (gas)	D11	3
Fireplaces and hearths (oil)	D12	4
Flue pipes (oil)	D13	4
Chimneys (oil)	D14	4
Timber frame construction	D15	5
Provision of information	D16-D17	5

## **MATERIALS**

Materials standards	M1	5
Bricks	M2	5
Concrete blocks	M3	5
Stone masonry	M4	6
Mortar	M5	6
Flue liners	M6	6
Flue pipes	M7	6
Flue terminals	M8	6
Flue blocks for gas appliances	M9	6
Twin wall flue systems	M10	6
Flashings	M11	6
Damp proof course	M12	6

## **SITWORK**

Sitework standards	S1	6
Fireplaces and hearths	S2	6
Flues	S3	7
Chimneys	S4	7
Terminals	S5	9
Provision of combustion air	S6	9
Testing	S7	9

## **APPENDIX 6.8-A**

Provision of combustion air	10
-----------------------------	----

## **APPENDIX 6.8-B**

Minimum sizes for flues contained in chimneys	10
---	----

## **APPENDIX 6.8-C**

Typical construction details	11/14
------------------------------	-------

## **APPENDIX 6.8-D**

Flue outlet positions for solid fuel appliances	15
---	----

## **APPENDIX 6.8-E**

Flue outlet position for gas appliances	16/17
---	-------

## **APPENDIX 6.8-F**

Flue outlet positions for oil appliances	18
--	----

## **INDEX**

19

## SCOPE

This Chapter gives guidance on meeting the Technical Requirements and recommendations for fireplaces, chimneys and flues.

### DESIGN STANDARDS

#### 6.8 - D1 Design shall meet the Technical Requirements

Design that follows the guidance below will be acceptable for fireplaces, chimneys and flues.

In this Chapter a number of terms are used. Details are given in Appendix 6.8-C.

### STATUTORY REQUIREMENTS

#### 6.8 - D2 Design shall comply with all relevant statutory requirements

Design should be in accordance with relevant Building Regulations and other statutory requirements.

### GENERAL CONSIDERATIONS

#### 6.8 - D3 Chimneys and flues shall enable efficient operation of the appliance for which they are designed while protecting the fabric of the building

The design of dwellings which incorporate chimneys and flues should ensure that all details of the associated elements are considered and, where necessary, provided. This should include the following:

- combustion air supply
- constructional hearth
- chimneys and flues, including where they project through the roof
- terminals
- construction adjacent to hearths and flues
- limitations on the type of appliance or open fire which can be installed or fuel which can be used.

Where a chimney or flue is provided it should be continuous from the hearth or appliance to the outside air.

A notice plate containing safety information about any hearths and flues should be securely fixed in an unobtrusive but obvious position within the home.

### Solid fuel

### FIREPLACES AND HEARTH

#### 6.8 - D4 Fireplaces and hearths shall be designed to ensure proper combustion of fuel and to minimise the risk of the building catching fire in consequence of their use

Where appliances are not provided, it is important to construct fireplaces and hearths to suit the appliance most likely to be fitted.

Items to be taken into account include:

##### (a) combustion air

Combustion air is vital to the safe and efficient operation of appliances. Solid fuel appliances should have an air supply either directly or indirectly from the external air

to comply with statutory requirements and manufacturers' recommendations. Reference should be made to Appendix 6.8-A.

#### (b) provision of hearths and recesses

##### HEARTH

Constructional hearths of sufficient dimensions should be provided for open fires or closed combustion appliances to comply with statutory requirements and manufacturers' recommendations. The dimensions shown in Clause S2 are for a concrete hearth at least 125mm thick below an open fire.

The hearth for a freestanding appliance should have minimum dimensions of 840mm. The following diagram shows the minimum dimensions from the appliance to the edge of the hearth.

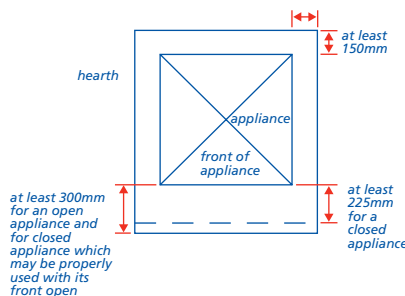

##### RECESSES

Recesses for open fires or closed combustion appliances should be provided to comply with statutory requirements and manufacturers' recommendations. Appendix 6.8-C gives some recess dimensions. The diagrams in Clause S2 show minimum masonry thickness surrounding the fireplace recess. Recesses are generally lined with a fire back or fire bricks.

For recess openings up to 500mm x 550mm, a 200mm diameter flue or square section of equivalent area can be used. For openings larger than this the flue size should be 15% of the area of the recess opening.

### WALLS NEAR APPLIANCES

#### 6.8 - D5 Walls near appliances and their hearths shall be located to minimise the risk of fire to the building

Walls near an appliance or its hearth should be non-combustible or the appliance should be positioned not closer to the wall than shown in the following diagrams.

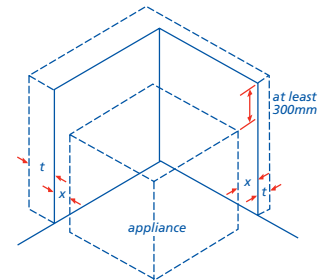
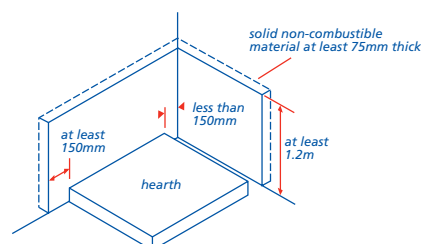

*t = thickness of solid non-combustible material as follows:  
if  $x$  is 50mm or less,  $t =$  at least 200mm  
if  $x$  is 50mm to 150mm,  $t =$  at least 75mm*

### FLUE PIPES

#### 6.8 - D6 Flue pipes shall be correctly designed to safely connect an appliance to a flue

Items to be taken into account include:

##### (a) size

Flue pipes should be equal to the cross-section of the outlet of the appliance they serve.

##### (b) direction

Flue pipes for solid fuel appliances should be vertical or inclined at 45° or less from vertical. A short horizontal section not exceeding 150mm long may be used to connect a back outlet appliance to a flue.

##### (c) jointing

Flue pipes which have spigot and socket joints should be fitted socket up.

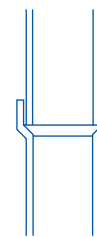

##### (d) separation from combustible materials

Flue pipes should be separated from combustible materials by at least the following:

- 200mm of non-combustible materials, or
- an airspace at least 4 times the diameter of the flue pipe, or
- shielded by a non-combustible shield at least 3 times the diameter of the flue pipe in width. The shield should be at least 12mm from the combustible material and the combustible material at least 1.5 times the diameter either side of the flue pipe.

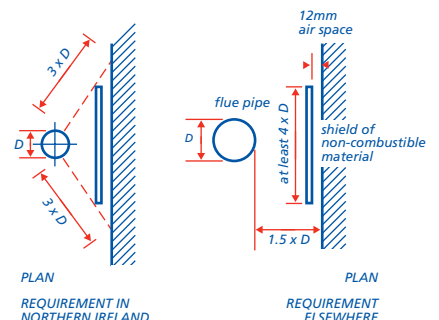

PLAN  
REQUIREMENT IN  
NORTHERN IRELAND

PLAN  
REQUIREMENT  
ELSEWHERE

## CHIMNEYS AND FLUES

**6.8 - D7 Chimneys shall incorporate flues capable of safely conducting products of combustion to the external air. The structure shall be capable of supporting the flue lining and shall provide adequate protection to the adjacent structure**

A notice plate containing safety information about any hearths and flues should be securely fixed in an unobtrusive but obvious position within the home.

Items to be taken into account include:

### (a) flue size

A flue should serve only one appliance. Flues should be of sufficient cross sectional area to remove all combustion gases from the open fire or appliance they serve.

Appendix 6.8-B gives flue sizes for:

- open fires
- solid fuel appliances.

### (b) flue direction and length

Flues for solid fuel appliances should:

- be vertical where possible but not have more than two bends
- not have bends more than 45° from the vertical
- be not less than 4.5m high for solid fuel appliances measured above the fireplace opening.

### (c) separation from adjacent spaces and materials

Combustible materials close to any brick or blockwork chimney should be:

- at least 200mm from the inside surface of a flue, or
- in all areas except Scotland, 40mm from the face of the chimney.

This does not apply to a floorboard, skirting, dado or picture rail, mantelshelf or architrave.

Materials used for chimneys should be capable of resisting fluctuating temperatures up to 1100°C. Suitable materials are described in the Materials section of this Chapter.

Flues for solid fuel appliances should be formed within masonry walls at least 100mm thick or 200mm thick if separating the flue from another compartment of the same building, another building or another dwelling. In Scotland, suitable masonry materials are described in the Building Standards (Scotland) Regulations.

Flues in the same chimney should be separated by masonry at least 100mm thick.

Timber framed wall design should include full details of separation proposals.

### (d) flue liners

Flue liners should:

- have rebated or socketed joints with socket or internal rebate uppermost

- be non-combustible
- be reasonably smooth internally
- be correctly jointed with mortar with the space between the liners and the brickwork filled with weak insulating concrete unless the manufacturer recommends an alternative specification
- incorporate compatible purpose made bends at changes of direction; cut pipes are not acceptable
- be properly jointed at their junctions with the starter block or lintel and the outlet terminal.

### (e) cleaning

Where a chimney is not directly over an appliance or opening, a soot box accessible for emptying should be formed.

### (f) resistance to frost attack

Clay brick chimneys above roof level which are not protected by a capping with adequate overhang and drip should be constructed with F2,S1 or F2,S2 bricks to BS EN 771 bedded in mortar of 1 : ½ : 4 to 4½, cement : lime : sand or 1 : 3 or 4, cement : sand with plasticiser (see Chapter 6.1 'External masonry walls', Appendix 6.1-C). In Scotland, all external facing brickwork should be constructed using frost resistant bricks.

Sulfate resisting cement should be used in the mortar where flue gases are liable to affect the masonry, eg above roof level.

If external chimneys built with clay bricks of F2,S1 designation are rendered, sulfate resistant cement should be used.

### (g) resistance to weather

Cavities in *Very Severe* and *Severe* exposure areas should be continuous up to roof level. This only applies below roof level where the stack forms part of an external cavity wall and applies to the complete structure including the fireplace recess. Where the chimney breast is gathered in, the lower projecting masonry should be protected against damp penetration with a suitable capping and cavity trays. Reference should be made to Appendix 6.8-C for typical construction details. Alternatives may be suitable.

Above the roof, chimney dpcs should link with flashings. Two dpcs should be used at suitable levels when the roof is steeply pitched, that is where the difference in level between the lower and higher intersection of the chimney with the roof will be more than 450mm. Lead trays should be protected with a thick coat of bitumen or bitumen paint where in contact with mortar. Plastic dpcs are not suitable. Weatherproofing details are included in Appendix 6.8-C.

Face brickwork above roof level should not have recessed joints.

If chimneys are to be rendered, the rendering should be as described in Chapter 6.1 'External masonry walls'.

### (h) stability

## FOUNDATIONS

Where a chimney forms part of a wall, the foundation should project at least 100mm wider than the chimney base. Where the chimney will exert higher loading on the supporting sub-soil than the adjacent wall, the chimney foundation spread should be designed to avoid uneven settlement. The depth of chimney foundations should be the same as adjacent wall foundations.

## HEIGHT

The height **H** of an unrestrained chimney should not exceed 4½ times the least plan dimension of the chimney, **W** (see diagram in Clause S4), provided the density of the masonry is at least 1500kg/m<sup>3</sup>, unless designed by an Engineer in accordance with Technical Requirement R5.

### (i) factory-made insulated chimneys

This type of chimney should be designed in accordance with BS 4543 and BS EN 1859 and installed in accordance with BS 7566 or be assessed in accordance with Technical Requirement R3.

An operating life of at least 30 years is required.

## CHIMNEY TERMINALS

**6.8 - D8 The terminal to a chimney shall enable satisfactory discharge of flue gases**

Items to be taken into account include:

### (a) position of the outlet

Outlets should be positioned as shown in Appendix 6.8-D. Refer to approved Document J where roof coverings are easily ignitable.

### (b) pressure zones

The design should, where possible, allow for the effects of adjacent trees, buildings etc. on the "low pressure" zone as the efficiency of the flue may be affected.

A low pressure zone generally occurs on the lee side and at the ridge of a pitched roof and close to the windward side of a flat roof. The flue will generally function more effectively if the outlet is in this zone, taking account of prevailing winds.

Where down-draughts occur, for example on hillsides or near tall trees and buildings, the height of the flue outlet may have to be increased or a fan assisted flue installed.

### (c) terminals

Terminals may be purpose-made components, built into the top of the chimney to a depth of not less than 125mm into the masonry or one-quarter the length of the terminal, whichever is the greater. The terminal should be sealed to the flue liners. The top flue liner projecting at least 20mm above the chimney capping is an acceptable terminal.

## (d) chimney cappings

Chimney cappings should be designed to protect the masonry below. Cappings should preferably be monolithic slabs, weathered, projecting at least 50mm with a drip to shed water clear of the masonry. Brick chimneys which do not have this type of capping should be constructed using frost resistant masonry.

All external face brickwork in Scotland should be constructed using frost resistant bricks.

Cappings may be designed as a cover slab supported on piers to reduce the rain penetration into the top of the flue. The height of the supporting piers should be sufficient to allow a total free opening area at least twice the area of the flue outlet.

CHIMNEY POT

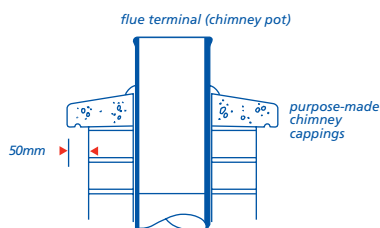

FLUE LINING ACTING AS FLUE TERMINAL

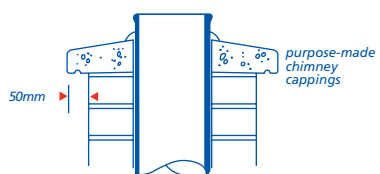

## Gas

### FIREPLACES AND HEARTHES

**6.8 - D9 Fireplaces and hearths shall safely accommodate the fire or appliance for which they are designed**

Items to be taken into account include:

#### (a) combustion air

Combustion air is vital to the safe and efficient operation of appliances. Requirements for combustion air are given in Appendix 6.8-A.

#### (b) provision of hearths and recesses

**SOLID FUEL EFFECT APPLIANCES**  
Hearths and recesses for solid fuel effect appliances should be as described for solid fuel installations or in accordance with BS 6714 or BS 5871 or the manufacturer's instructions when the appliance has been tested by an approved authority.

#### BACK BOILERS

Hearths for back boilers should be constructed of solid non-combustible materials at least:

- 125mm thick, or
- 25mm thick placed on non-combustible supports at least 25mm high.

The diagram below shows minimum projections for the hearth beyond the appliance.

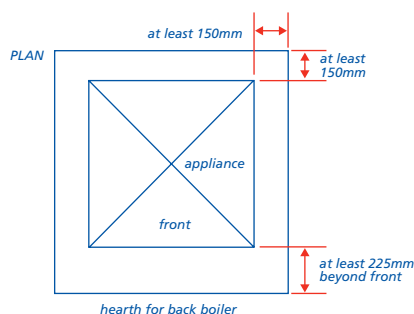

#### ALL OTHER GAS APPLIANCES

Hearths for other types of appliance should be at least 12mm thick non-combustible material to the same plan dimensions as above. In some cases the provision of a hearth is not required, for example if the flame or incandescent material is at least 225mm above the floor.

Where a hearth has been provided, its edges should be marked to provide a warning to the home owner and to discourage combustible floor finishes such as carpet from being laid too close to the appliance. A way of achieving this would be to provide a change in level.

#### (c) separating appliances from combustible materials

Appliances should not be closer than 75mm to combustible material. This applies to the back, sides and top of the appliance and any draught-diverter. It does not apply if a 25mm thick non-combustible shield is used or the appliance complies with the appropriate parts of BS 5258 or BS 5386.

### FLUE PIPES

**6.8 - D10 Flue pipes shall safely connect an appliance to a chimney or a flue to a terminal**

Items to be taken into account include:

#### (a) size

Flue pipes should be at least the area of the outlet of the appliance and have no adjustable draught control.

#### (b) direction

Apart from balanced flues, horizontal runs should be avoided. No pipe should exceed 45° with the vertical.

#### (c) jointing

Flue pipes with spigot and socket joints should be fixed socket up.

#### (d) connections and support

Purpose-made connections should be used particularly in roof spaces when connecting to flue blocks and to ridge terminals. The connecting flue pipe should be supported on straps at centres not greater than 1.8m and have support directly below each socket.

#### (e) separation from combustible materials

Single wall flue pipes should be separated from combustible materials by:

- at least 25mm
- a non-combustible sleeve enclosing an air space of at least 25mm around the pipe where it passes through a wall, floor or roof
- non-combustible casing material with at least half the fire resistance needed for the wall or floor where passing through a compartment wall or compartment floor.

The 25mm may be measured from the outside of the inner pipe in the case of double-walled pipes (see BS 5440).

## CHIMNEYS

**6.8 - D11 Chimneys shall incorporate flues capable of safely conducting products of combustion from an appliance to the external air. The structure shall be capable of supporting the flue and providing adequate protection to adjacent materials**

Chimneys for gas appliances must not incorporate an adjustable draught control.

Items to be taken into account include:

#### (a) masonry chimneys

Flues should be of the minimum sizes given in Appendix 6.8-B.

Masonry chimneys as described for solid fuel are acceptable.

Brick or blockwork chimneys for gas appliances should provide at least the fire resistance of any compartment wall or floor of which it forms part or passes through (the compartment wall may form the chimney wall if it is a masonry material).

#### (b) flue liners

Flue liners should be as described for solid fuel or comply with BS 715 (see Clause D7(d)). Flexible flue liners are not acceptable for new build.

#### (c) flue block chimneys

Flue blocks should comply with BS EN 1858 or BS EN 1806 with a performance class of at least FB4 N2. The chimney should only be constructed of flue blocks if suitable for the appliance.

Flue block chimneys should be constructed, jointed and weatherproofed in accordance with manufacturers' instructions.

Flue blocks should be correctly bonded to the flanking masonry.

In all areas, the nominal cavity width as required in Chapter 6.1, should be maintained by either:

- increasing the overall width of the cavity, or
- making the flue block flush with the inside of the cavity but projecting into the room as a false chimney breast.



# 6.8 Fireplaces, chimneys and flues

Flue blocks projecting into the cavity should be protected by providing a vertical dpm. The dpm may be supported by building in a layer of suitable non-combustible insulation.

Plaster should not be applied directly to flue blocks. A plasterboard lining with an airspace or non-combustible insulation behind should be provided.

Flue blocks should not be built into separating walls unless it can be shown that the wall has adequate sound resistance.

## (d) factory-made insulated chimneys and terminals

Factory-made insulated chimneys should:

- comply with the requirements of BS 4543 and be installed in accordance with BS 6461 or comply with BS 715 and installed in accordance with BS 5440.

Factory-made insulated chimneys should be assembled, erected, anchored and protected in accordance with manufacturers' instructions.

## (e) terminals to masonry chimneys

If appropriate, flue terminals should comply with the appliance manufacturer's recommendations.

Proprietary terminals should comply with BS 715 and BS EN 1858.

Where proprietary terminals are not used, the free opening area should be at least twice the area of the flue. The openings should be uniformly distributed around the terminal or be on two opposite faces. The openings in the terminal should admit a 6mm diameter ball but exclude a ball over 25mm diameter.

## (f) direction

Flues should be vertical where possible. Any necessary bend in a flue should not make an angle exceeding 45° with the vertical.

## (g) outlets not serving balanced flue appliances

A flue outlet serving a gas appliance should be:

- situated at roof level, so that air can pass freely across it at all times
- at least 600mm from any opening into the building
- fitted with a flue terminal where the flue diameter is less than 170mm. Larger diameter flues should be fitted with a terminal where required by Building Regulations.

## (h) outlets serving balanced flue appliances

See Appendix 6.8-E for position of balanced flue outlets.

## (i) damp penetration

Precautions should be taken where appropriate to prevent damp penetration as described for solid fuel chimneys.

Balanced flues which bridge the cavity of an external wall should have a means of preventing moisture crossing the cavity, for example, a moisture drip collar set in the centre of the cavity.

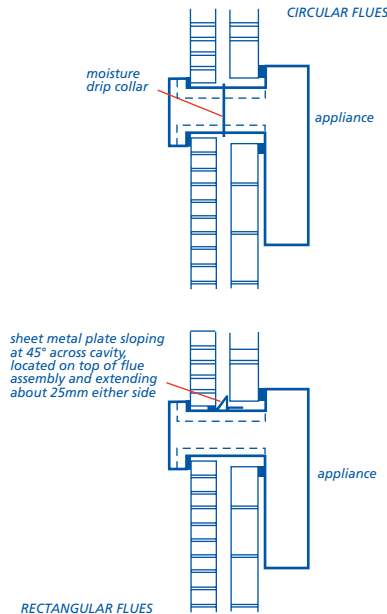

## (b) direction

As for solid fuel.

## (c) separation from adjacent spaces and materials

See Clause D14 (c).

## CHIMNEYS

**6.8 - D14 Chimneys shall incorporate flues capable of safely conducting products of combustion from an open fire or other appliance to the external air. The structure shall be capable of supporting the flue lining and shall provide adequate protection to adjacent materials**

Items to be taken into account include:

## (a) size of flue

Flue sizes should be in accordance with Appendix 6.8-B.

## (b) direction of flues

As for gas flues.

## (c) separation from adjacent spaces and materials

Separation should be in accordance with the following table.

Protecting buildings from hot flues for flue gas temperatures not more than 250°C	
Flue within:	Protection measures
Connecting fluepipe	Flues should be at least 25mm from any combustible material (measured from the outer surface of the flue wall, or the outer surface of the inner wall in the case of multi-walled products). Where passing through a combustible wall, floor or roof (other than a compartment wall floor or roof) this separation can be achieved by a non-combustible sleeve enclosing the fluepipe or chimney with a 25mm airspace to the relevant flue wall. (The airspace could be wholly or partially filled with non-combustible insulating material).
Factory-made chimney complying with BS 715:1993	Refer to appropriate British Standards and Manufacturers recommendations.
Masonry chimney	Provide at least 25mm of masonry between flues and any combustible material.
Flueblock chimney	Provide flueblock walls at least 25mm thick.

## Oil

## FIREPLACES AND HEARTHES

**6.8 - D12 Fireplaces and hearths shall safely accommodate the fire or appliance for which they are designed**

Items to be taken into account include:

## (a) combustion air

Combustion air is vital to the safe and efficient operation of appliances. Reference should be made to Appendix 6.8-A.

## (b) provision of hearths

If the temperature of the hearth below the appliance is likely to exceed 100°C, or the temperature is not known, a hearth should be provided as described for solid fuel appliances. If this temperature is unlikely to be exceeded the appliance may stand on a rigid, non-combustible imperforate sheet of material without a constructional hearth.

## (c) shielding appliances

Appliances which are likely to have back or side temperatures exceeding 100°C should be shielded as described for gas appliances (see Clause D9(c)).

## FLUE PIPES

**6.8 - D13 Flue pipes shall safely connect an appliance to a chimney**

Items to be taken into account include:

## (a) size

Flue pipes should be at least the size of the outlet to the appliance. Reference should be made to Appendix 6.8-B.

Flue assemblies for roomed-sealed appliances	<p>a) flues passing through combustible walls should be surrounded by insulating material at least 50mm thick.</p> <p>b) provide a clearance of at least 50mm from the edge of the flue outlet to any combustible wall cladding.</p>
--	--

\* BS 4543-1:1990 (1996) withdrawn April 2000; partially superseded by BS EN 1859:2000

#### (d) flue liners

As for gas if the flue gases are unlikely to exceed a temperature of 250°C. As for solid fuel if the flue gases are likely to exceed a temperature of 250°C or the temperature is not known.

#### (e) resistance to heat

As for gas flue pipes if the flue gases are unlikely to exceed a temperature of 250°C. As for solid fuel flue pipes if the flue gases are likely to exceed a temperature of 250°C or the temperature is not known.

#### (f) resistance to chemical attack

As for solid fuel.

#### (g) resistance to weather

As for solid fuel.

#### (h) separation from combustible materials

As for gas flue pipes if the flue gases are unlikely to exceed a temperature of 250°C. As for solid fuel flue pipes if the flue gases are likely to exceed a temperature of 250°C or the temperature is not known.

#### (i) stability

As for solid fuel if of masonry construction.

#### (j) factory-made insulated chimneys

This type of chimney should be designed in accordance with BS 4543 : Part 1 to Part 3 BS EN 1859 and installed in accordance with BS 7566 : Part 2 or be assessed in accordance with Technical Requirement R3. An operating life of at least 30 years is required. Component systems to be BS 715 installed in accordance with BS 5440.

#### (k) outlets

See Appendix 6.8-F for positions of flue outlets.

All balanced flue terminals should be positioned to allow free intake of air to the appliance.

#### (l) terminals

As for solid fuel if of masonry construction, unless otherwise stated in the appliance manufacturer's instructions, which should be followed.

## General

### TIMBER FRAME CONSTRUCTION

**6.8 - D15 Fireplaces, chimneys and flues in timber frame construction shall be designed to minimise the risk of the building catching fire**

The design of timber frame construction should ensure that combustible material is either far enough away from heat sources or, where permitted, shielded.

Designers may find the following 'Institution of Gas Engineers' publications useful:

- 'Guide for gas installation in timber framed housing'
- 'Specification for flues for class II appliances in timber framed housing'.

Appendix 6.8-C contains a detail of an external fireplace recess and chimney. Other details for internal chimneys and chimneys in separating walls are available in TRADA publications.

### PROVISION OF INFORMATION

**6.8 - D16 Design and specifications shall be produced in a clearly understandable format and include all relevant information**

For fireplaces and flues the drawings should show:

- position and size of hearths and fireplaces
- position and size of chimneys and flues
- position and proximity of combustible materials
- position and details of flue terminals or outlets
- position of dpcs and flashings
- construction details of fireplace openings and chimney connections
- details of materials to be used
- limitations on the type of appliance or open fire which can be installed or fuel which can be used
- details of tests required on chimneys and flues including who is responsible for carrying them out.

**6.8 - D17 All relevant information shall be distributed to appropriate personnel**

Ensure that design and specification information is issued to site supervisors and relevant specialist subcontractors and/or suppliers.

Where proprietary products are to be used, manufacturers usually have specific requirements for fixing and/or assembly of their products. This information should also be made available for reference on site so that work can be carried out satisfactorily in accordance with the design and specification.

## MATERIALS STANDARDS

**6.8 - M1 All materials shall: (a) meet the Technical Requirements (b) take account of the design**

Materials that comply with the design and the guidance below will be acceptable for fireplaces, chimneys and flues.

Materials for fireplaces, chimneys and flues shall comply with all relevant standards, including those listed below. Where no standard exists, Technical Requirement R3 applies (see Chapter 1.1 'Introduction to the Standards and Technical Requirements').

References to British Standards and Codes of Practice include those made under the Construction Products Directive (89/106/EEC) and, in particular, appropriate European Technical Specifications approved by a European Committee for Standardisation (CEN).

### BRICKS

**6.8 - M2 Bricks shall be capable of supporting intended loads and have appropriate resistance to the adverse effects of frost and sulfates**

Bricks should be selected in accordance with BS 6461 and BS EN 771.

In external chimney stacks clay bricks should be of durability rating F2,S1 as described in BS EN 771 unless protected by a projecting capping bedded on a dpc. In Scotland frost resistant bricks should be used for all external facing brickwork.

Reference should also be made to Chapters 6.1 'External masonry walls' (Materials) and 6.3 'Internal walls' (Materials).

### CONCRETE BLOCKS

**6.8 - M3 Blocks shall be capable of supporting intended loads and have appropriate resistance to the adverse effects of frost and sulfates**

Blocks should be selected in accordance with BS 6461 Part 1, BS EN 771 or satisfactorily assessed in accordance with Technical Requirement R3. Block density should be minimum 1500 kg/m<sup>3</sup>, unless designed by an Engineer in accordance with Technical Requirement R5.

Reference should also be made to Chapters 6.1 'External masonry walls' (Materials) and 6.3 'Internal walls' (Materials).

In Scotland, 100mm thick blockwork in chimney construction should have a density of at least 1600 kg/m<sup>3</sup>. Other suitable masonry specifications for Scotland are given in the Building Standards (Scotland) Regulations.



# 6.8 Fireplaces, chimneys and flues

## STONE MASONRY

**6.8 - M4 Stone masonry shall be capable of supporting intended loads and have appropriate resistance to the adverse effects of frost and sulfates**

Stone for masonry should comply with the requirements of BS EN 771 and BS 6461 : Part 1.

Reconstructed stone masonry units should comply with BS EN 771-5 and BS 6461 : Part 1.

## MORTAR

**6.8 - M5 Mortar shall be batched and mixed to achieve adequate strength and durability to comply with design**

Mortar should be as specified for areas of *Severe* or *Very Severe* exposure in Chapter 6.1 'External masonry walls' Appendix 6.1-B. (1 : ½ : 4 to 4½ cement : lime : sand or 1 : 3 or 4 cement : sand with plasticiser).

Sulfate resisting cement should be used in the mortar where flue gases are liable to affect the masonry, eg above roof level.

## FLUE LINERS

**6.8 - M6 Flue liners shall be unaffected by flue gases and suitable for their purpose**

Special fittings should be specified at changes of direction of the flue.

Liners suitable for solid fuel appliances (and generally suitable for other fuels) could be:

- liners whose performance is at least equal to that corresponding to the designation T450 N2 S D 3, as described in BS EN 1443: 1999, such as:
  - clay flue liners with rebates or sockets for jointing meeting the requirements for Class A1 N2 or Class A1 N1 as described in BS EN 1457: 1999; or
  - concrete flue liners meeting the requirements for the classification Type A1, Type A2, Type B1 or Type B2 as described in prEN 1857(e18) January 2001; or
  - other products that are independently certified as meeting the criteria in a); or
- imperforate clay pipes with sockets for jointing as described in BS 65: 1991 (1997).

Liners should be installed in accordance with their manufacturer's instructions. Appropriate components should be selected to produce the flue path without cutting and to keep joints to a minimum. Bends and offsets should only be formed with purpose-made components. Liners need to be placed with the sockets or rebate ends uppermost to contain water and other condensates in the flue. Caulking can be effected with fire cement or refractory mortar. Spaces between the lining and the surrounding masonry should not be filled with ordinary mortar.

In the absence of liner manufacturer's instructions, the space could be filled with a weak insulating concrete such as mixtures of:

- one part ordinary Portland cement to 20 parts suitable lightweight expanded clay aggregate, minimally wetted; or
- one part ordinary Portland cement to 6 parts Vermiculite; or
- one part ordinary Portland cement to 10 parts Perlite.

## FLUE PIPES

**6.8 - M7 Flue pipes shall be suitable for their purpose**

Cast iron flue pipes should comply with BS 41.

Mild steel flue pipes should have a minimum wall thickness of 3mm and comply with BS 1449.

Stainless steel flue pipes should be at least 1mm thick as described in BS EN 10088 and should be one of the following grades: 1.4401, 1.4404, 1.4432 or 1.4436.

Vitreous enamelled flue pipes should be of low carbon steel coated internally and externally with acid resisting enamel and conform to the description given in BS 6999.

Flue pipes for gas appliances should comply with BS 715.

All flue pipes should be jointed in accordance with manufacturers' instructions.

## FLUE TERMINALS

**6.8 - M8 Flue terminals shall be suitable for their purpose**

Clay flue terminals should comply with or be constructed from materials which comply with BS 1181.

Chimneys serving gas appliances should have terminals complying with BS EN 1858. Flue pipes serving gas appliances should have terminals complying with BS 715.

## FLUE BLOCKS FOR GAS APPLIANCES

**6.8 - M9 Flue blocks for gas appliances shall be unaffected by flue gases and suitable for their purpose**

Flue blocks for use with gas appliances should comply with BS 1289 : Part 1 (Concrete) or Part 2 (Clay). In situations where the cavity width is reduced by the flue block all insulation and vertical dpms should be in accordance with manufacturers' instructions.

## TWIN WALL FLUE SYSTEMS

**6.8 - M10 Twin wall flue systems shall be suitable for their purpose**

Twin wall flue systems should comply with BS 715 or be assessed in accordance with Technical Requirement R3.

## FLASHINGS

**6.8 - M11 Flashings and trays shall be capable of adequately resisting the entry of moisture into the building**

Suitable materials for flashings and trays are:

- milled sheet lead (at least Code 4) complying with BS EN 12588
- aluminium and aluminium alloys complying with BS 1470 (0.6mm to 0.9mm thick)
- zinc alloy complying with BS 6561 and 0.6mm thick.

## DAMP-PROOF COURSE

**6.8 - M12 Materials for damp-proofing shall resist adequately the passage of moisture into the building**

The following are acceptable for use as dpms:

- bitumen to BS 6398
- polyethylene to BS 6515 (not in the chimney stack above roof level)
- proprietary materials assessed in accordance with Technical Requirement R3.

## SITWORK STANDARDS

**6.8 - S1 All sitework shall:**

- meet the Technical Requirements
- take account of the design
- follow established good practice and workmanship

Sitework that complies with the design and the guidance below will be acceptable for fireplaces, chimneys and flues. Gas appliances should be fitted by a Gas Safe Register (GSR) installer to comply with the Gas Safety (Installation and Use) Regulations 1998.

Good workmanship and effective supervision during construction are essential to ensure that fireplaces, chimneys and flues function correctly in use.

Additional construction details are shown in Appendix 6.8-C.

## FIREPLACES AND HEARTHES

**6.8 - S2 Fireplaces and hearths shall safely accommodate the appliances for which they are designed**

Fireplace recesses should be constructed of solid non-combustible material as shown below:

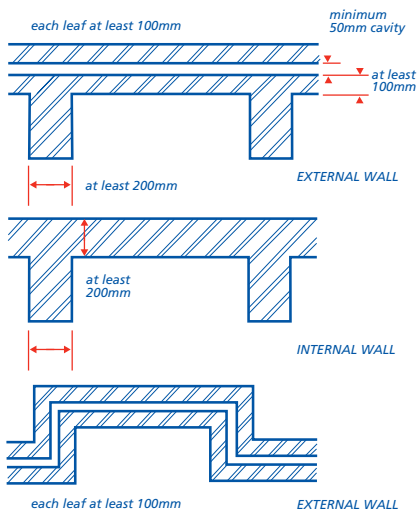

The space between a fireback and any masonry forming the recess should be filled with vermiculite concrete (1 : 4, lime : vermiculite with water).

Combustible material should not be placed under a constructional hearth unless it is:

- to support the edges of the hearth or
- separated from the underside of the hearth by an airspace of at least 50mm or
- at least 250mm from the material to the top of the hearth.

Hearths should be at least the sizes shown below. Hearths for freestanding appliances should be at least 840mm square.

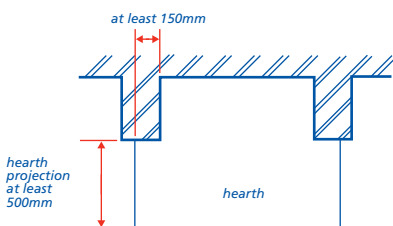

## FLUES

**6.8 - S3 Flues shall provide an unrestricted passage for combustion gases between the fireplace or appliance and the outlet**

Items to be taken into account include:

### (a) cleaning

The bottom of flues not directly over an appliance should be provided with a means of access for cleaning and inspection.

### (b) connections to appliances

The connection between a fireplace or appliance and the flue should be correctly constructed (see details in Appendix 6.8-C).

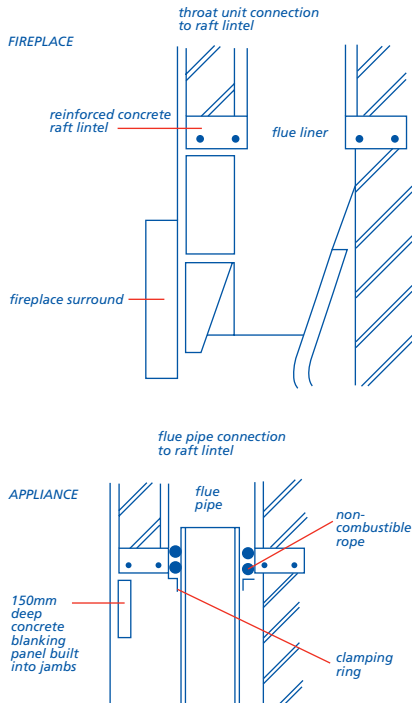

### (c) flue draught control unit

Where adjustable throat units are specified they should be fitted in accordance with manufacturers' instructions. Adjustable flue draught control units are not permitted where gas burning appliances are installed.

### (d) flue pipes

Flue pipes should be fixed 'socket up' and correctly aligned. Longer flue pipes forming flues from gas appliances should be supported at a maximum of 1.8m centres and have support directly below each socket.

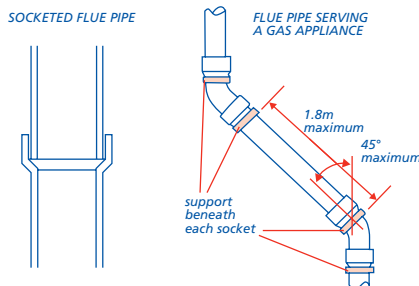

### (e) flue liners

The space between flue liners and masonry should be filled with weak insulating concrete or manufacturers' recommendations with specified material providing adequate protection.

Flue linings to chimneys should be clay or purpose made concrete as specified by the design.

Flue linings should be handled carefully to prevent chipping or cracking.

Bends or tees should be purpose made for use with the lining system being installed.

Flue linings should be sealed at their joint with the starter block or throat unit. No cavity should be formed between the linings and the starter elements.

Flue linings should be installed socket up.

Changes of direction of flue liners should be formed using purpose made fittings.

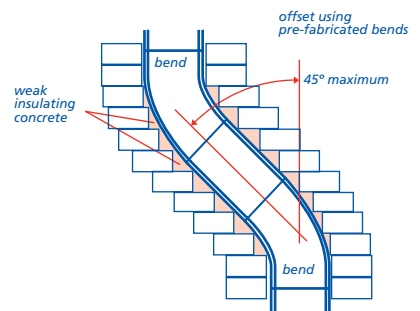

CHIMNEY WITH FLUE LINERS SUITABLE FOR SOLID FUEL

Jointing material for flue liners should be fire cement or refractory mortar, unless the manufacturers' instructions require an alternative jointing to be used.

Each joint should be fully filled and all surplus material cleared from the inside of each joint as the flue is built.

### (f) fire hazards

Combustible materials close to any brick or blockwork chimney should be:

- at least 200mm from a flue, or
- except in Scotland, 40mm from the face of the chimney.

This does not apply to a floorboard, skirting, dado or picture rail, mantelshelf or architrave.

Metal fixings in contact with combustible materials should be at least 50mm from a flue.

## CHIMNEYS

**6.8 - S4 Chimneys shall provide fire protective casing for flues, and shall be capable of adequately supporting the flue liner and resisting damp penetration and the products of combustion**

Items to be taken into account include:

### (a) stability

Masonry chimneys should be properly bonded to, or supported by, adjoining walls of the building. The depth of chimney foundations should be the same as any adjacent wall foundation.

# 6.8 Fireplaces, chimneys and flues

The height **H** of an unrestrained chimney should not exceed 4½ times the least plan dimension of the chimney **W** (see diagram), provided the density of the masonry is at least 1500kg/m<sup>3</sup>, unless designed by an Engineer in accordance with Technical Requirement R5.

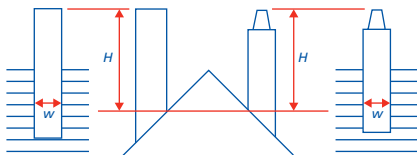

## (b) wall thickness

Chimneys of block, brick or stone should have a minimum wall thickness of 100mm excluding the lining thickness.

A chimney forming part of a compartment wall and not back to back with an adjacent chimney should have a wall thickness of at least 200mm separating it from the other building or dwelling.

Chimneys built in a cavity separating wall should form two leaves each of at least 100mm thickness between the flue and adjoining building.

## (c) damp penetration

The damp proof course to the main walls should be carried through the base of chimneys.

Damp proof courses, flashings and gutters should be provided at the intersection point of the chimney with the surface of the roof through which the chimney passes.

Metal elements making up dpcs and flashing should be compatible non-ferrous metals. Lead trays should be bitumen coated where in contact with cement.

Occasional damp penetration below roof level may occur in chimneys which exit close to the ridge of a pitched roof. This is acceptable in a well ventilated roof space provided that any dampness penetrating downwards is unlikely to reach the living areas.

Where chimneys exit close to the eaves of a pitched roof or through a flat roof, trays and flashings should be installed in the chimney so that all damp penetration is prevented.

The weatherproofing details shown in Appendix 6.8-C should be used in Very Severe and Severe exposure zones. In lower exposure zones the tray upturn may be on the outside of the flue liner.

## (d) coring

A core is a sack, full of loose straw or the like, used to block the flue during the construction of a chimney with circular linings. The core, which is attached to a rope to pull it up the flue, keeps the flue clean and free of falling mortar and debris which may later form an impedance to gases passing through the flue.

Ensure that the core is removed on completion of the chimney.

## (e) drying

A chimney should be allowed to dry naturally for at least 14 days before use.

## (f) masonry chimneys

### BRICKS

Frost resistant bricks should be used above the roof unless protected by a capping projecting at least 50mm. In Scotland, frost resistant bricks should be used for all facing brickwork.

Below roof level the bricks and mortar may be the same as those used for general brickwork.

Mortar should be as specified for areas of *Severe* and *Very Severe* exposure in Chapter 6.1 'External masonry walls' Appendix 6.1-C. (1 : ½ : 4 to 4½, cement : lime : sand or 1 : 3 or 4, cement : sand with plasticiser).

Sulfate resisting cement should be used in the mortar where flue gases are liable to affect the masonry, eg. above roof level.

### BLOCKS

Hollow or cellular blocks, suitable for the construction of chimneys, should only be used if the voids are filled with concrete as the work proceeds.

## (g) flue block chimneys

Gas flue block chimneys are only suitable for gas appliances. Their suitability should be checked before connecting any appliance.

Flue block chimneys should be constructed, jointed and weather proofed in accordance with the design and manufacturers' instructions. A high standard of workmanship should be maintained to ensure that the flue is clean and sealed.

Flue blocks should be correctly bonded to the flanking masonry.

Where gas flue blocks are shown in the design they will be at least 140mm wide. This may be wider than the wall leaf.

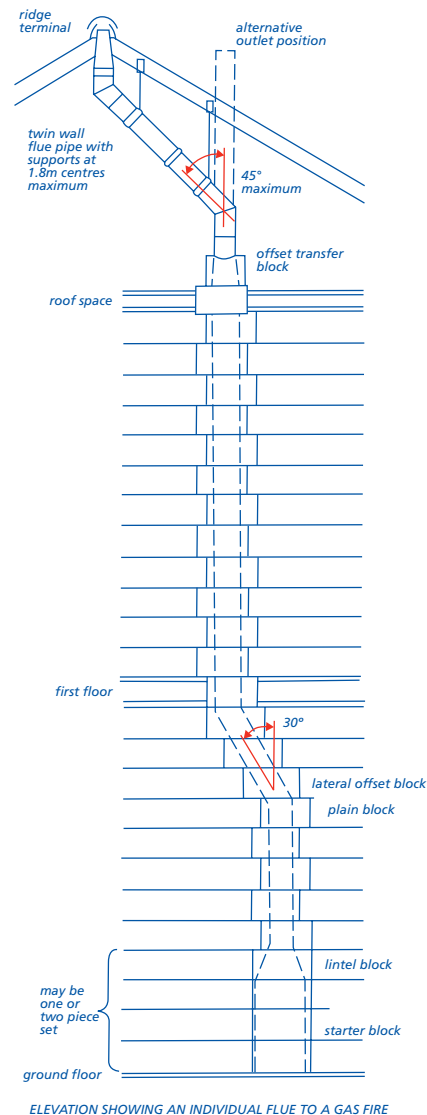

The design will show how the extra thickness is incorporated by either:

- increasing the overall width of the cavity, or
- making the flue block flush with the inside of the cavity but projecting into the room as a false chimney breast.

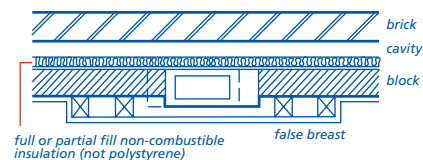

Where the cavity is shown to be reduced the flue block should be protected by a vertical dpm. The dpm should be supported by building in a layer of non-combustible insulation.

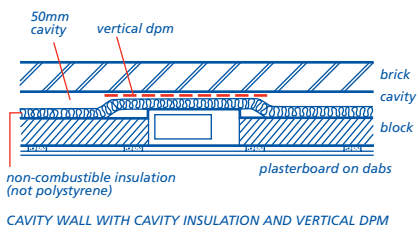
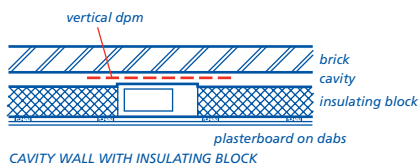

Plaster should not be applied directly to flue blocks. A plasterboard lining with an airspace or non-combustible insulation behind should be provided. Insulated dry lining may be unsuitable in this situation unless separated from the flue block.

### (h) connection between flue block chimney and roof outlet

Connections between flue blocks and ridge terminals should be made as detailed in the design using the correct fittings and supports as specified by the manufacturers of the flue blocks, flue pipe and the ridge terminal.

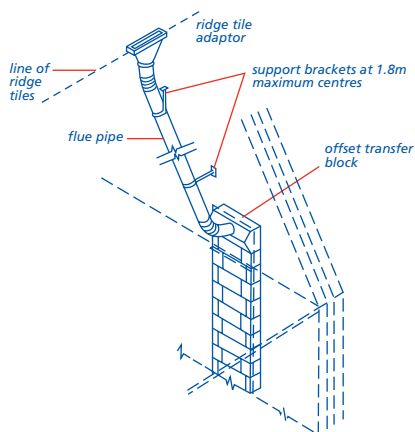

### (i) factory-made insulated chimneys

Factory-made insulated chimneys should be assembled, erected, anchored and protected in accordance with manufacturers' instructions.

## TERMINALS

### 6.8 -S5 Terminals shall assist the proper functioning of the flue

Terminals should be purpose made or formed by extending the flue lining not less than 20mm above the head of the chimney. Various terminals are shown in Appendix 6.8-C.

Items to be taken into account include:

#### (a) stability

Terminals should be embedded at least 125mm into the chimney excluding any flaunching, or one quarter the length of the terminal, whichever is the greater.

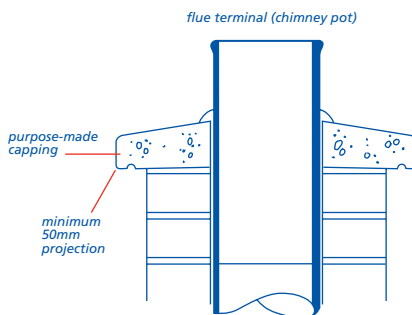

Appendix 6.8-C gives details of brickwork capping.

#### (b) jointing

The terminal of a masonry flue should be jointed to the flue lining with cement mortar to form a seal.

#### (c) size

Terminals should be the same cross sectional area as the flue which for solid fuel is not less than 200mm diameter.

#### (d) draught improvement

In cases where down draughts may occur, special terminals designed to increase up draught should be fitted.

A special terminal will not overcome problems caused by high pressure zones. Where relevant, the Solid Fuel Association or other authoritative body should be consulted.

#### (e) chimney capping

Where a chimney is to be capped, a single unjointed concrete or stone capping should be used. The capping should project and be throated to cast rainwater away from the face of the chimney. The slab should project 50mm beyond the faces of the chimney. The widths between flues should be carried to the underside of the slab.

Decorative brick cappings should be carefully constructed to avoid rain penetration and frost damage. The use of frost resistant bricks may be required. All bricks used for facing brickwork in Scotland should be frost resistant.

## PROVISION OF COMBUSTION AIR

### 6.8 - S6 Installations shall have an adequate supply of air to ensure satisfactory combustion of fuel and the efficient working of flues and chimneys

Combustion air is vital to the safe and efficient operation of appliances. Reference should be made to Appendix 6.8-A.

## TESTING

### 6.8 - S7 Installations shall be tested before use

#### ALL FLUES

All flues should be checked during construction to ensure that there are no obstructions in the flue and that mortar or other blockages are removed. When the flue is complete, if practical a visual check should be made and any obstructions cleared.

#### FLUES FOR SOLID FUEL APPLIANCES

##### Coring ball test

When a visual test cannot be carried out or is inconclusive, the coring ball test should be carried out.

A suitable concrete or metal ball is attached to a strong cord or rope. The ball is lowered slowly from the flue outlet to the bottom of the flue (the fireplace recess or the appliance connection). If a blockage or obstruction is found it must be removed and the test repeated until the flue is completely clear of obstruction.

##### Smoke test

This test is designed to show that a flue draws adequately and that there are no leaks between the appliance and the terminal.

The smoke test is carried out when neither the flue to be tested nor adjacent flues are in use. The flue is first warmed for about 10 minutes with a heat source such as a blow lamp. If an appliance is fitted it should be completely closed as should any flue access doors.

Two purpose made smoke pellets are then placed in the appliance firebox or in the bottom of the flue and ignited. The appliance, chimney or fireplace opening should then be closed or sealed off and the smoke allowed to rise. When smoke appears at the top of the flue the outlet should be sealed with a blow-up rubber ball or other air tight closing system.

The whole structure forming the flue should be inspected externally on all sides and from top to bottom for smoke leakage. This should include the top of cavity walls and any other possible smoke paths, even those terminating some distance from the flue. The test should be continued for at least 5 minutes.

#### FLUES FOR GAS APPLIANCES

More sophisticated flue tests may be required for some gas appliances. These tests should be carried out by the appliance installer.

#### FLUES FOR OIL APPLIANCES

Flues for oil fired appliances should be tested as required by the appliance manufacturer.

# 6.8 Fireplaces, chimneys and flues

## APPENDIX 6.8-A

### Provision of combustion air

	Solid fuel up to 45kW output		Gas *	Oil
	Open	Closed appliance **	Up to 70kW input	Up to 45kW output
<b>England, Wales and Isle of Man</b>	50% of throat area***	550mm <sup>2</sup> /kW above 5kW rating	500mm <sup>2</sup> /kW above 7kW input for an appliance in a room or space	550mm <sup>2</sup> /kW above 5kW rating for an appliance in a room or space
<b>Scotland</b>	1500mm <sup>2</sup> for fireplaces up to 450mm wide (measured between firebricks), for fireplaces exceeding 450mm width manufacturers' details should be followed	As England and Wales	As BS 5440: Part 2 (as England and Wales)	As England and Wales
<b>Northern Ireland</b>	As England and Wales	550mm <sup>2</sup> up to 6kW rating. Over 6kW add 550mm <sup>2</sup> for each kW above 6kW.	450mm <sup>2</sup> up to 8kW. Over 8kW add 450mm <sup>2</sup> for each kW above 8kW	As solid fuel closed appliance

#### Notes:

Full details of ventilation requirements for all types of appliances are contained in the relevant building regulations.

\* Decorative fuel effect gas appliances should have a provision for combustion air complying with the relevant part of BS 5871.

Normally a minimum of 10,000mm<sup>2</sup> of purpose provided ventilation is required. Air vents should be direct to the external air or to an adjacent room or internal space which has an air vent or vents to the external air of at least the same free area. Air vents should have aperture dimensions no smaller than 5mm.

\*\* Where closed appliances use a flue fitted with a draught stabiliser the total free area should be increased to 300mm<sup>2</sup>/kW for the first 5kW plus 850mm<sup>2</sup>/kW for the balance of appliance output.

\*\*\*In the case of a fire with a canopy the open air vents should be 50% of the flue area.

## APPENDIX 6.8-B

### Minimum sizes for flues contained in chimneys

#### Solid fuel burning appliance up to 45kW output

Serving	Minimum flue size [mm]
Fireplace recess with an opening up to 500mm x 550mm	200 diameter or square section of equivalent area
Fireplace with larger opening	See approved Document J
Closed appliance up to 20kW rated output burning smokeless fuel	125 diameter or square section of equivalent area
Closed appliance up to 30kW rated output burning any fuel	150 diameter or square section of equivalent area
Closed appliance above 30kW and up to 50kW rated output burning any fuel	175 diameter or square section of equivalent area

#### Non fan-assisted individually flued gas burning appliances up to 70kW input excluding balanced flue

Serving	Minimum flue size
Gas fire	Round flue with a cross-sectional area of at least 12,000mm <sup>2</sup> (125mm diameter) or rectangular flue with a cross-sectional area of at least 16,500mm <sup>2</sup> with minimum dimension of 90mm
Any other	At least the cross-sectional area of the outlet from the appliance

#### Inset live or decorative gas fuel effect appliances

Serving	Minimum flue size
Open fire within a fireplace opening up to 500mm x 550mm	Circular or rectangular minimum flue dimension 175mm

#### Oil burning appliances up to 45kW output

Not less than the size of the appliance outlet
--

**APPENDIX 6.8-C**

**Typical construction details**

**KEY TO TERMS**

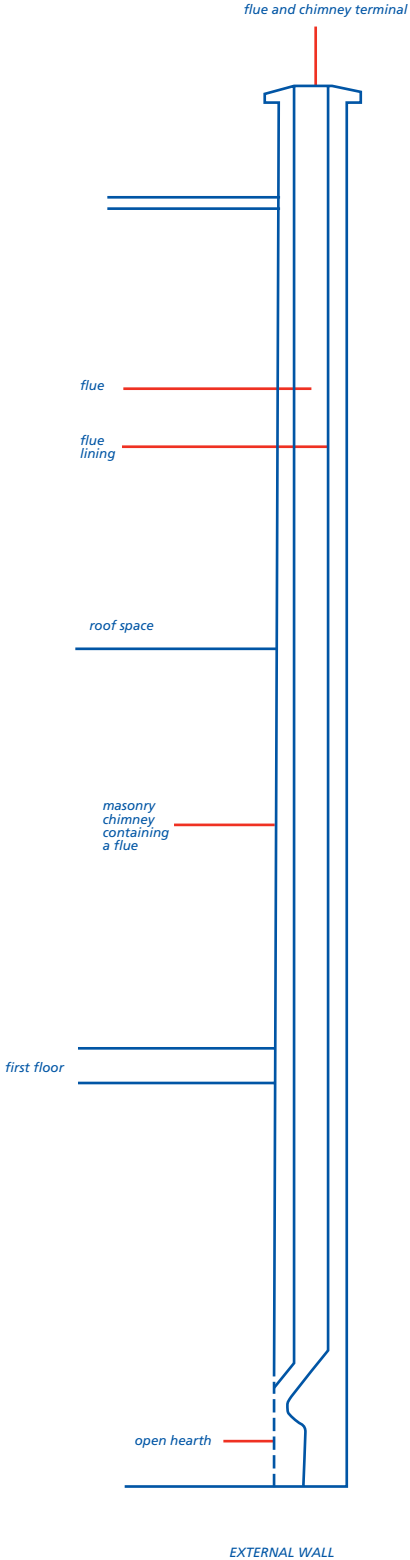
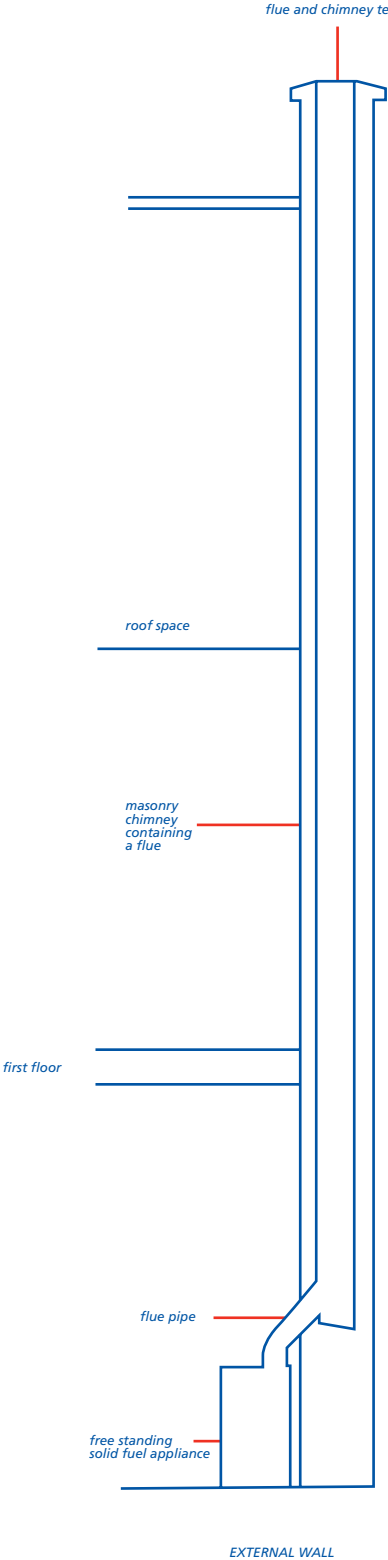
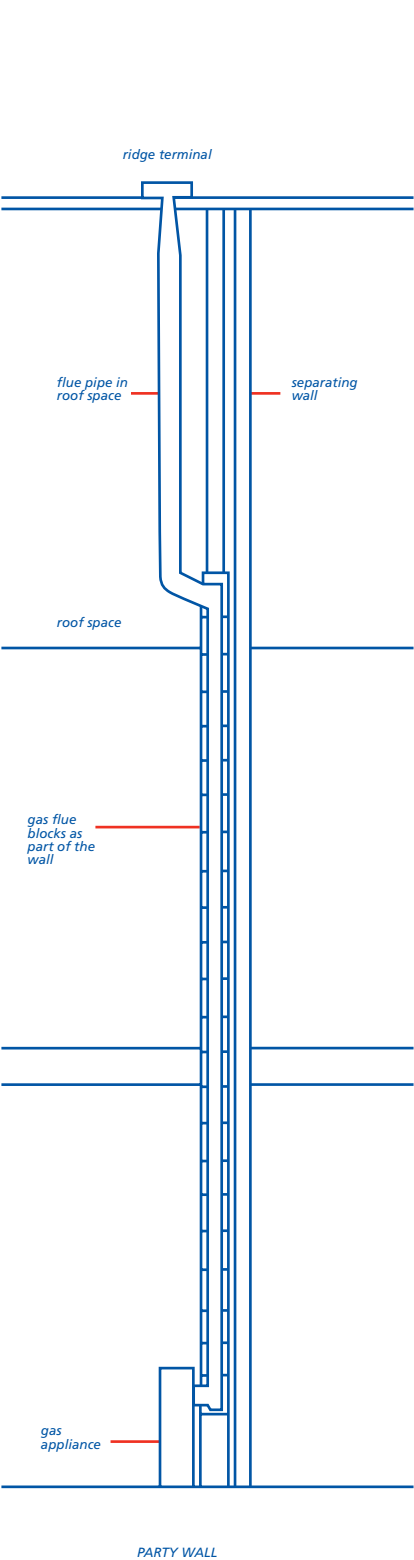

**6.8**



# 6.8 Fireplaces, chimneys and flues

For weathering detail see Detail C

## DETAILS OF EXTERNAL CHIMNEY BREAST WITH MASONRY INNER LEAF

Other alternatives may be suitable provided they meet the appropriate Performance Standards.

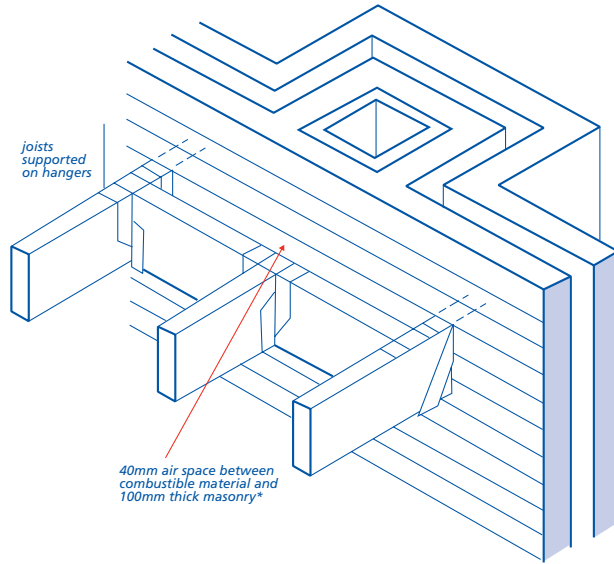
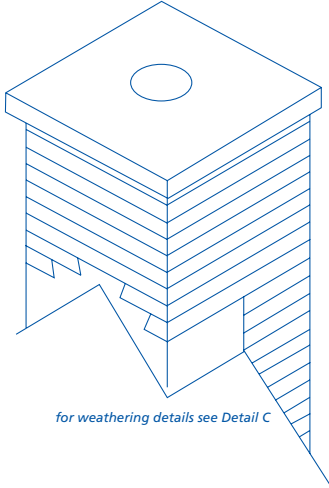

\*in Scotland, joists, etc should be at least 200mm from inner surface of flue. Brickwork or blockwork in chimney construction should be at least 100mm thick and have a density of at least 1600 kg/m<sup>3</sup>. Aircrete blocks may be used if at least 150mm thick

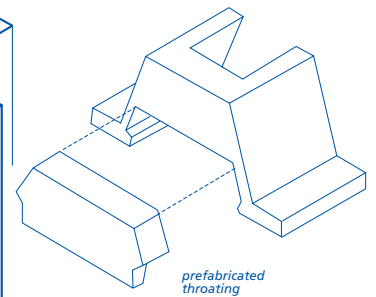
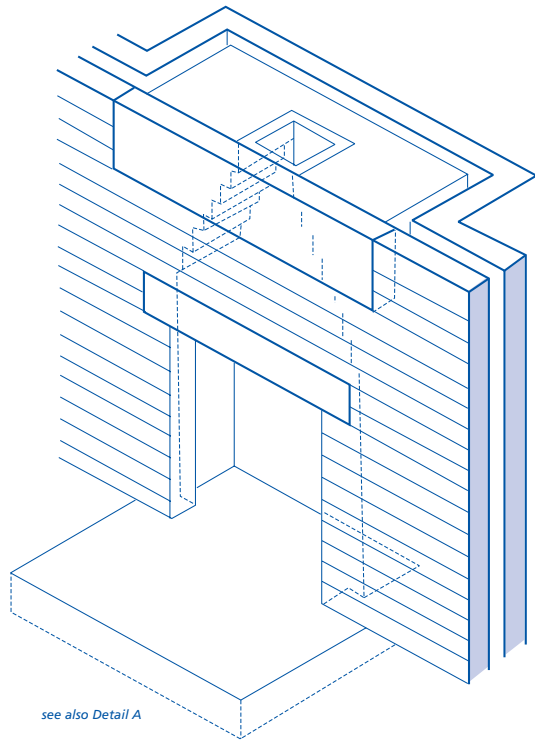
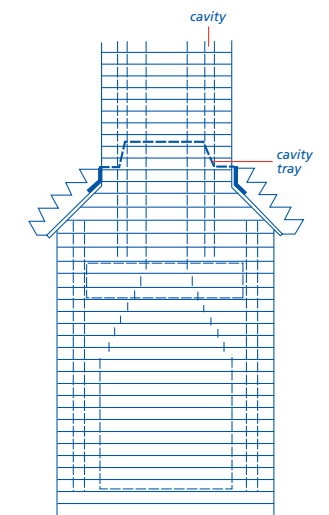
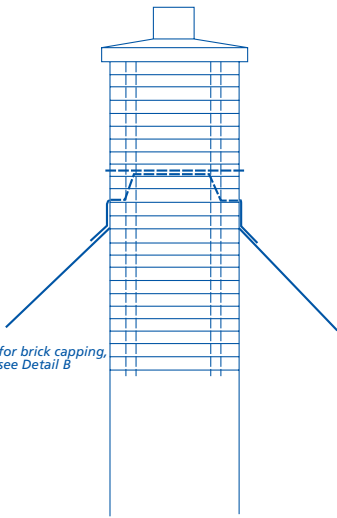



**DETAIL A**

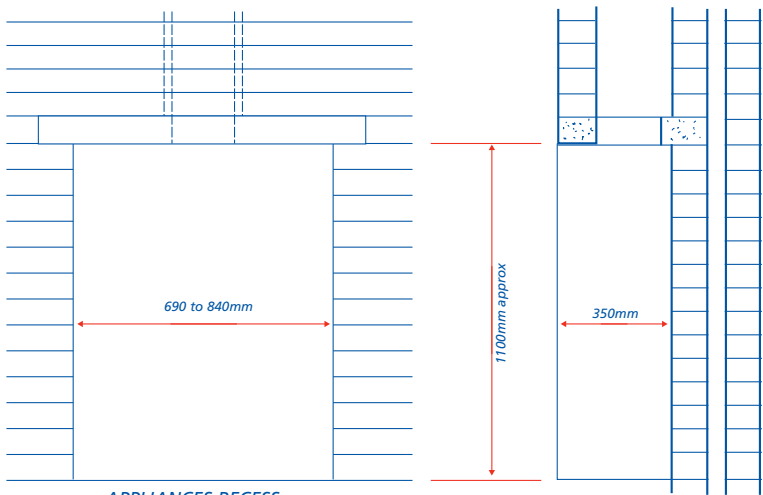

**APPLIANCES RECESS - WITH RAFT LINTEL, SUITABLE FOR FREE STANDING ROOM HEATER**

**DETAIL B**

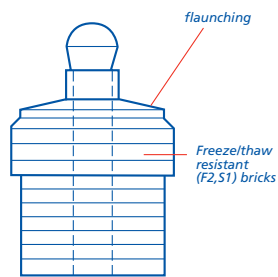

**CHIMNEY DETAIL WITH BRICK CAPPING**

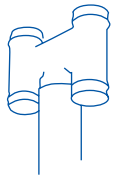
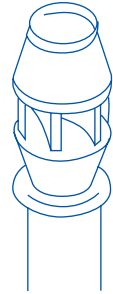
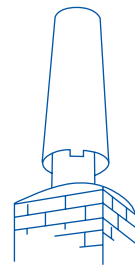

**VARIOUS TERMINALS (see Clause S5)**

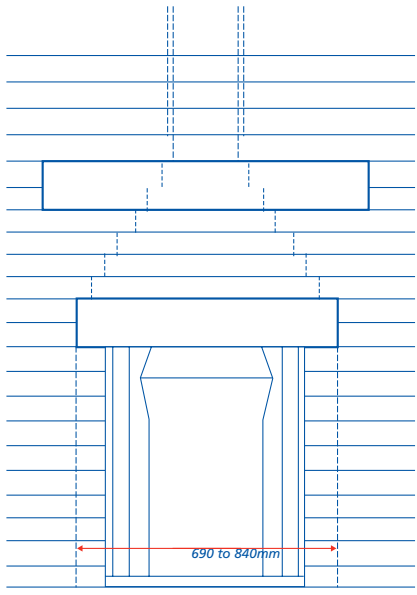

**FIREPLACE RECESS - FOR INSET OPEN FIRE (WITHOUT BOILER UNIT)**

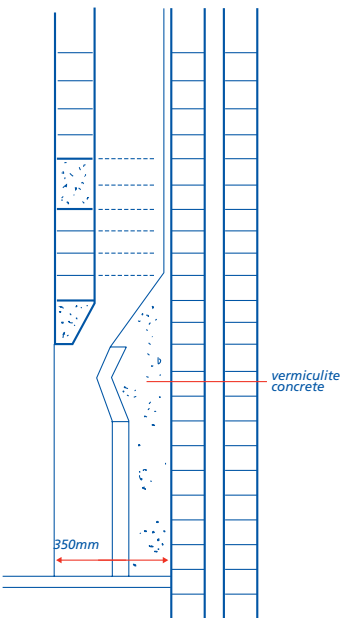

# 6.8 Fireplaces, chimneys and flues

## DETAIL C

Weatherproofing details recommended for use in *Very Severe* and *Severe* exposure zones.

In other exposure zones the dpc tray can be dressed up the outside of the flue liner.

Note: All flashings and trays in chimneys to be metal (see Clause M11).

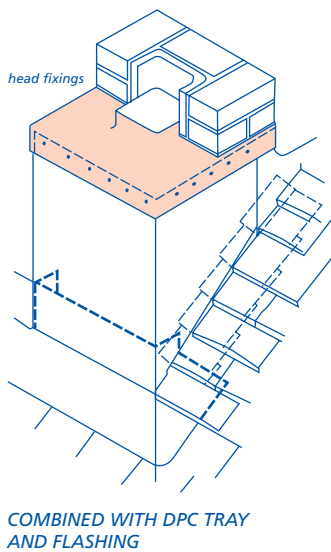
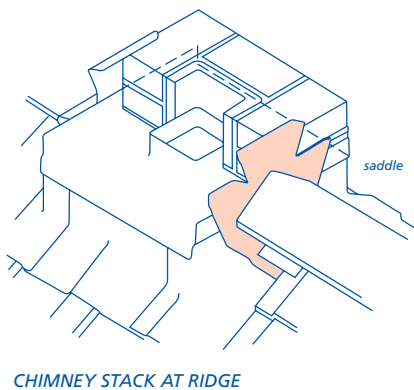
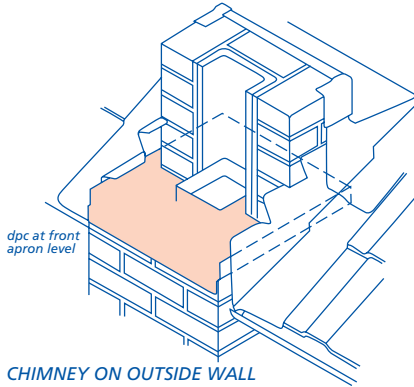

## TYPICAL EXTERNAL FIREPLACE RECESS AND CHIMNEY-TIMBER FRAME CONSTRUCTION

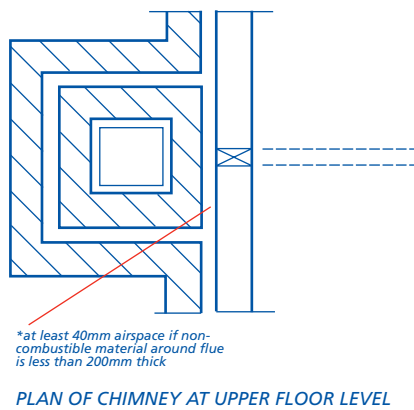
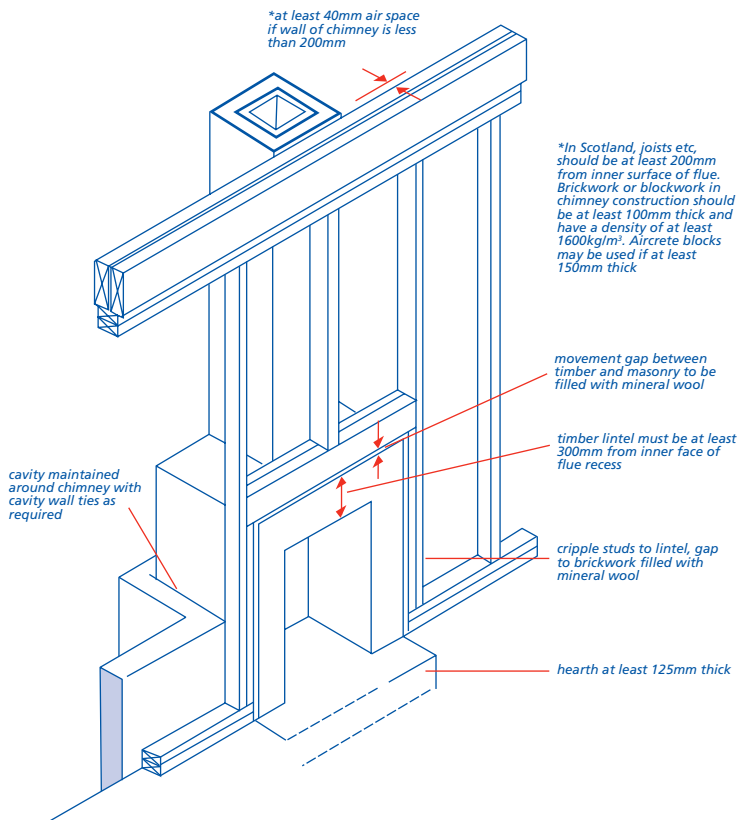
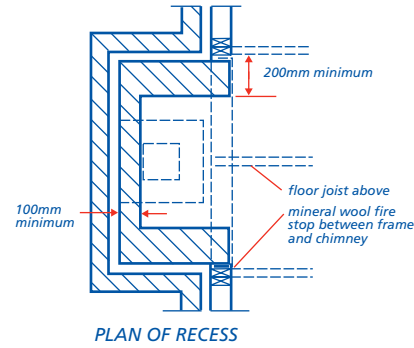

6.8

## APPENDIX 6.8-D

### Flue outlet positions for solid fuel appliances

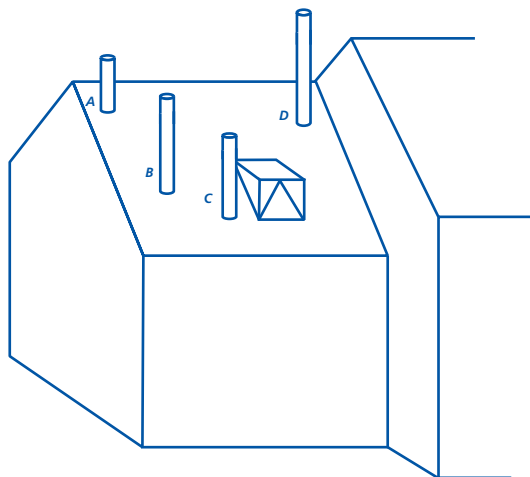

	Point where flue passes through weather surface (Notes 1,2)	Clearance to flue outlet
<b>A</b>	at or within 600mm of the ridge.	at least 600mm above the ridge.
<b>B</b>	elsewhere on a roof (whether pitched or flat)	at least 2300mm horizontally from the nearest point on the weather surface and: a) at least 1000mm above the highest point of intersection of the chimney and the weather surface: or b) at least as high as the ridge.
<b>C</b>	below (on a pitched roof) or within 2300mm horizontally to an openable rooflight, dormer window or other opening, (Note 3)	at least 1000mm above the top of the opening.
<b>D</b>	within 2300mm of an adjoining or adjacent building, whether or not beyond the boundary, (Note 3)	at least 600mm above the adjacent building.

#### Notes

- 1 The weather surface is the building external surface, such as its roof, tiles or external walls.
- 2 A flat roof has a pitch less than 10°.
- 3 The clearance given for A or B, as appropriate, will also apply.

# 6.8 Fireplaces, chimneys and flues

## APPENDIX 6.8-E

### Location of outlets from flues servicing gas appliances

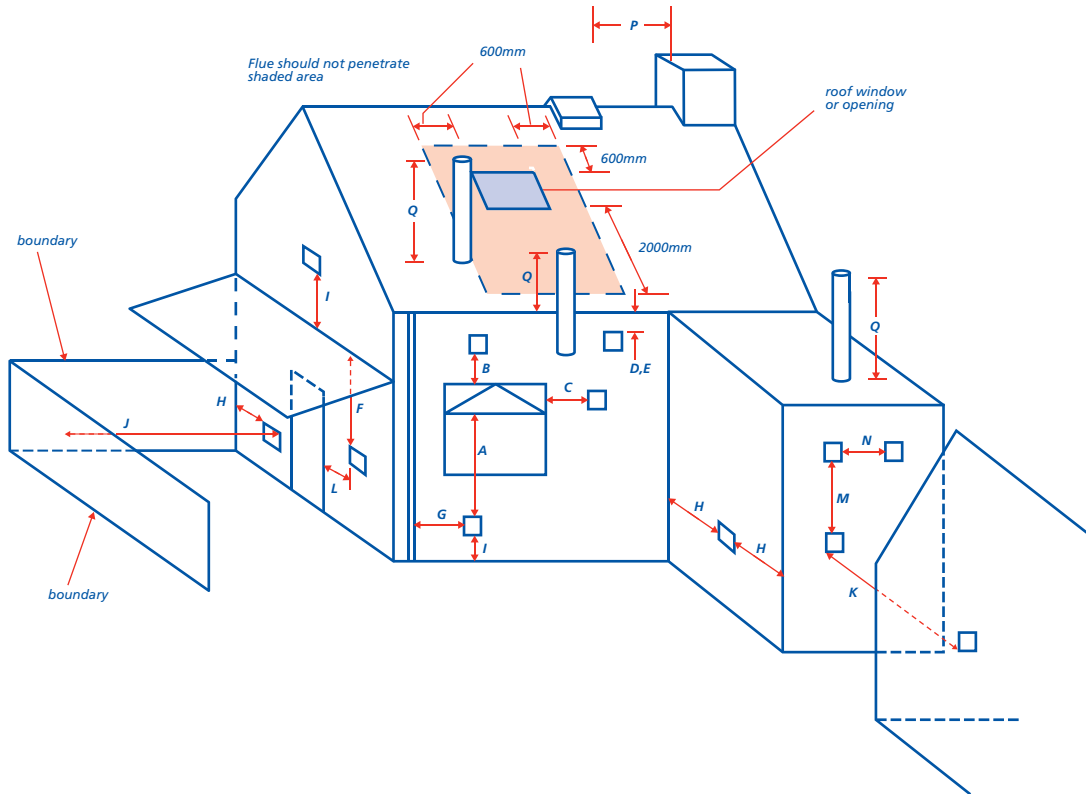

## Location of outlets from flues serving gas appliances

Minimum separation distances for terminals in mm

Location	Balanced flue			Open flue	
		Natural draught	Fanned draught	Natural draught	Fanned draught
<b>A</b> Below an opening (1)	Appliance rated heat input (net)	300	300	(3)	300
	0-7kW >7-14kW >14-32kW >32kW	300 600 1500 2000			
<b>B</b> Above an opening (1)	0-32kW >32kW	300 600	300	(3)	300
<b>C</b> Horizontally to an opening (1)	0-7kW >7-14kW >14kW	300 400 600	300	(3)	300
<b>D</b> Below gutters, soil pipes or drain pipes	300		75	(3)	75
<b>E</b> Below eaves	300		200	(3)	200
<b>F</b> Below balcony or car port roof	600		200	(3)	200
<b>G</b> From a vertical drainpipe or soil pipe	300		150 (4)	(3)	150
<b>H</b> From an internal or external corner or to a boundary alongside the terminal (2)	600		300	(3)	200
<b>I</b> Above ground, roof or balcony level	300		300	(3)	300
<b>J</b> From a surface or a boundary facing the terminal (2)	600		600	(3)	600
<b>K</b> From a terminal facing the terminal	600		1200	(3)	1200
<b>L</b> From an opening in the car port into the building	1200		1200	(3)	1200
<b>M</b> Vertically from a terminal on the same wall	1200		1500	(3)	1500
<b>N</b> Horizontally from a terminal on the same wall	300		300	(3)	300
<b>P</b> From a structure on the roof	N/A		N/A	1500mm if a ridge terminal. For any other terminal, as given in BS 5440-1:2000	N/A
<b>Q</b> Above the highest point of intersection with the roof	N/A		Site in accordance with manufacturer's instructions	Site in accordance with BS 5440-1:2000	150

### Notes:

- 1 An opening here means an openable element, such as an openable window, or a fixed opening such as an air vent. However, in addition, the outlet should not be nearer than 150mm (fanned draught) or 300mm (natural draught) to an opening into the building fabric formed for the purpose of accommodating a built in element, such as a window frame.
- 2 Boundary as defined in Paragraph 0.4. of Approved Document J: smaller separations to the boundary may be acceptable for appliances that have been shown to operate safely with such separations from surfaces adjacent to or opposite the flue outlet.
- 3 Should not be used.
- 4 This dimension may be reduced to 75mm for appliances of up to 5kW input (net).
- 5 N/A means not applicable.

# 6.8 Fireplaces, chimneys and flues

## APPENDIX 6.8-F

### Location of outlets from flues serving oil-fired appliances

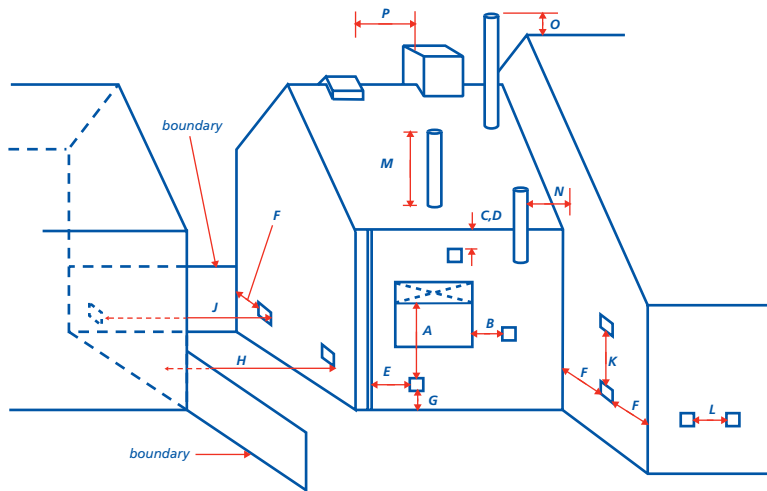

Minimum separation distances for terminals in mm

Location of outlet (1)	Appliance with pressure jet burner	Appliance with vaporising burner	
A	Below an opening (2, 3)	600	should not be used
B	Horizontally to an opening (2, 3)	600	should not be used
C	Below a plastic/painted gutter, drainage pipe or eaves if combustible material protected (4)	75	should not be used
D	Below a balcony or a plastic/painted gutter, drainage pipe or eaves without protection to combustible material	600	should not be used
E	From vertical sanitary pipework	300	should not be used
F	From an external or internal corner or from a surface or boundary alongside the terminal	300	should not be used
G	Above ground or balcony level	300	should not be used
H	From a surface or boundary facing the terminal	600	should not be used
J	From a terminal facing the terminal	1200	should not be used
K	Vertically from a terminal on the same wall	1500	should not be used
L	Horizontally from a terminal on the same wall	750	should not be used
M	Above the highest point of an intersection with the roof	600 (6)	1000 (5)
N	From a vertical structure to the side of the terminal	750 (6)	2300
O	Above a vertical structure which is less than 750mm (pressure jet burner) or 2300mm (vaporising burner) horizontally from the side of the terminal	600 (6)	1000 (5)
P	From a ridge terminal to a vertical structure on the roof	1500	should not be used

**Notes:**

- 1 Terminals should only be positioned on walls where appliances have been approved for such configurations when tested in accordance with BS EN 303-1:1999 or OFTEC standards OFS A100 or OFS A101.
- 2 An opening means an openable element, such as an openable window, or a permanently open air vent.
- 3 Notwithstanding the dimensions above, a terminal should be at least 300mm from combustible material, e.g. a window frame.
- 4 A way of providing protection of combustible material would be to fit a heat shield at least 750mm wide.
- 5 Where a terminal is used with a vaporising burner, the terminal should be at least 2300mm horizontally from the roof.
- 6 Outlets for vertical balanced flues in locations M, N and O should be in accordance with manufacturer's instructions.

**INDEX**

<b>A</b>		<b>G</b>		<b>W</b>	
Appliances	3, 4	Gas appliances	3, 6, 9, 10	Walls	1, 8, 11
<b>B</b>		<b>H</b>		Weather resistance	2, 5
Back boilers	3	Hearths	1, 3, 4, 6		
Balanced flues	4	Height	2, 15, 16, 17		
Bricks and blocks	5, 8	<b>M</b>			
<b>C</b>		Masonry chimneys	3, 8		
Cappings	3, 9, 12, 13	Mortar	6		
Chimney breasts	12, 14	<b>O</b>			
Chimney pots	2	Oil appliances	9, 10		
Chimneys	2, 3, 4, 7, 12, 13, 14	Outlets, position	2, 4, 5, 8, 9		
Cleaning, flues	2, 7	<b>P</b>			
Combustion air	1, 3, 4, 9, 10	Pressure zones	2		
Coring	8	<b>R</b>			
<b>D</b>		Recesses	1, 13, 14		
Damp penetration	4, 8	Render	2		
Damp proof courses	2, 6, 14	<b>S</b>			
Draught control unit	7	Smoke test	9		
<b>F</b>		Solid fuel	1, 3, 9, 10		
Fire hazards	1, 2, 7	Solid fuel effect appliances	3, 10		
Fireplaces	1, 3, 4, 6, 12, 13, 14	Stability	2, 5, 7, 9		
Flashings	6, 14	Stone masonry	5		
Flue block chimneys	3, 6, 8, 9	<b>T</b>			
Flue direction and length	2, 3, 4	Terminals	2, 4, 5, 6, 13		
Flue liners	2, 3, 5, 6, 7	Testing	9		
Flue pipes	1, 3, 4, 7, 10	Timber frame construction	5		
Flue size	1, 2, 3, 4, 10	Twin wall flue systems	6		
Foundations	2				
Frost resistance	2				





# Chapter 6.9

## Curtain walling and cladding

---



# 6.9 Curtain walling and cladding

## CONTENTS

	Clause	Page
<b>INTRODUCTION</b>		1
<b>DESIGN</b>		
Design standards	D1	2
Statutory requirements	D2	2
Design life	D3	2
Accessibility for maintenance	D4	2
<b>Curtain walling</b>		
Certification	D5	2
In-service performance	D6	3
<b>Rainscreen cladding</b>		
Certification	D7	4
In-service performance	D8	4
<b>Insulated render systems</b>		
Certification	D9	5
In-service performance	D10	5
<b>Brick slip cladding systems</b>		
Certification	D11	6
In-service performance	D12	6
<b>General</b>		
Provision of information	D13-D14	8
<b>MATERIALS</b>		
Material standards	M1	8
Dpc/dpm materials	M2	8
Glazing	M3	8
Gaskets	M4	8
Sealant	M5	8
Thermal insulation	M6	8
Breather membranes	M7	8
Cavity barriers and fire-stops	M8	8
Fixings	M9	9
Timber preservation	M10	9
Ventilation screens	M11	9
<b>SITWORK</b>		
Sitework standards	S1-S2	9
Handling and storage	S3	9
<b>Curtain walling</b>		
Location and fixing	S4	9
Weather resistance	S5	9
Glazing	S6	10
Control of condensation	S7	10
Allowance for movement	S8	10
Tolerances	S9	10
Testing	S10	10

<b>Rainscreen cladding</b>		
Location and fixing	S11	10
Weather resistance	S12	10
Allowance for movement	S13	11
Tolerances	S14	11
<b>Insulated render systems</b>		
Fixing	S15	11
Weather resistance	S16	11
Tolerances	S17	12
<b>Brick slip cladding systems</b>		
Fixing	S18	12
Weather resistance	S19	12
Tolerances	S20	13
<b>APPENDIX 6.9-A</b>		
Interfaces		13
<b>INDEX</b>		14

## SCOPE

This Chapter gives guidance on meeting the Technical Requirements and recommendations for curtain walling and cladding.

**INTRODUCTION**

This Chapter gives guidance on the forms of curtain walling and cladding acceptable to NHBC. Curtain walling and cladding systems that do not conform to the following descriptions will not normally be acceptable to NHBC.

Guidance on the use of other types of cladding including brickwork, rendered masonry, vertical tile & slate cladding and timber cladding is given in Chapter 6.1 'External masonry walls' and Chapter 6.2 'External timber framed walls'.

**CURTAIN WALLING**

This Chapter deals with the following curtain walling systems:

- prefabricated or site assembled support framework with infill panels or
- prefabricated factory assembled wall sections and glazing systems that include:
  - structural silicone glazing
  - mechanically fixed structural glazing
  - slope glazing (excluding patent glazing)
  - coupled door and window frame assemblies one storey or more in height (including spandrel panels).

Conservatories are not covered by this Chapter.

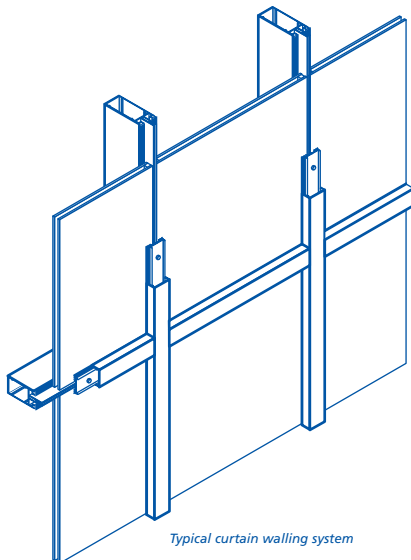

**RAINSCREEN CLADDING**

This Chapter deals with rainscreen cladding systems that comprise:

- an outer skin of panels, which have open, baffled, or labyrinth (rebated) joints. Joints should not be sealed
- a pressure equalised air gap at least 50mm wide between the insulation and the panels
- an insulated airtight backing wall.

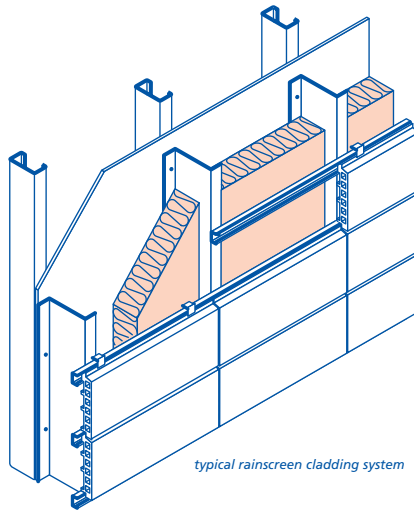

**INSULATED RENDER**

This Chapter deals with insulated render systems that are fixed to all types of backing wall.

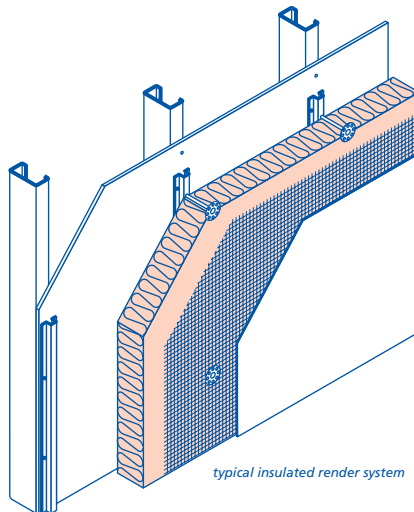

**BRICK SLIP CLADDING**

This Chapter deals with brick slip cladding systems that are fixed to all types of backing wall.

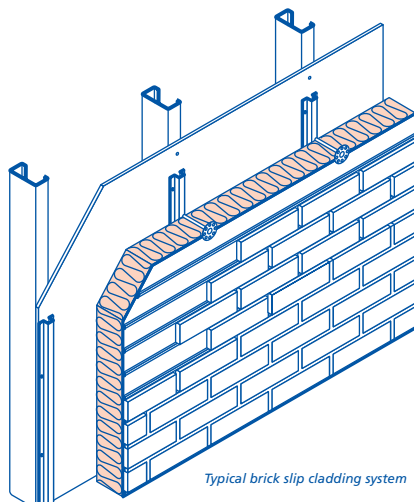

**STONE & PRECAST CONCRETE CLADDING**

Stone & precast concrete cladding should be designed as curtain walling or rainscreen cladding and comply with the relevant section of this Chapter.

**DEFINITIONS (FOR THIS CHAPTER)**

**Air barrier**

A continuous layer that limits air leakage through the backing wall.

**Air gap**

The space between the back of the cladding panels and the external face of the insulation in a rainscreen system.

**Air cushion**

Balancing external and internal air pressure to create a cushion within the air gap.

**Backing wall**

A framed or masonry wall to which the cladding system is fixed.

**Brick slip cladding system**

A brick slip system fixed to masonry or framed backing walls, normally supported by a proprietary carrier.

**Cavity**

The space between the cladding system and the backing wall. The cavity should be adequately drained, and where required by the design, be ventilated.

**Cladding panels**

The outer layer of a rainscreen cladding system that shields other parts of the system from direct rain.

**Compartmentation**

The provision of baffles and cavity closers to form compartments within the air gap of a rainscreen cladding system, to achieve pressure equalisation. Cavity barriers that are provided to control the spread of smoke and fire may also be used to form the compartments.

**Curtain walling**

A form of vertical building enclosure that supports no load other than its own weight and the environmental forces that act upon it, e.g. wind, water and solar. Curtain walling also includes slope glazing and coupled door and window frame assemblies one storey or more in height (including spandrel panels).

**Curtain walling system**

The vertical building enclosure system, including all frames, brackets, fixings, flashings, gutters, copings, glass, panels, gaskets and sealant that form the assembly.

**CWCT**

The Centre for Window and Cladding Technology at Bath University.

# 6.9

## Curtain walling and cladding

### CWCT Standards

The current CWCT Standards for Systemised Building Envelopes.

### Design life

The period for which materials, products and systems should be designed to be durable, assuming routine inspection and maintenance.

### Dpc/Dpm

Horizontal or vertical damp-proof course/membrane to prevent the passage of moisture. In curtain walling terminology, a dpc is sometimes referred to as a dpm.

### Façade

The face of a building which forms the outer appearance.

### Fire and smoke stopping

Preventing the transmission of fire and smoke through voids or cavities in the curtain walling or cladding assembly.

### Fixing

A component which is used to attach the curtain walling or cladding system to the structure.

### Gasket

A compressible material that forms an air and water seal at joints between components.

### In-service performance

The manner or quality of functioning for a material, product or system in use.

### Insulated render system

A proprietary render system applied to the external face of an insulation material that is in turn fixed to the backing wall.

### Interstitial condensation

Condensation caused by vapour condensing on colder surfaces within the wall construction.

### Negative pressure

Where the air pressure on the internal face of the system is greater than that on the external face.

### Positive pressure

Where the air pressure on the external face of the system is greater than that on the internal face.

### Primary components

Framing, fixings, insulation, vapour control layers, weathering components, cladding panels and other secondary components that are not easily replaceable.

### Pressure equalisation

The creation of an air cushion within the cavity to significantly reduce the amount of water passing through the joints of a rainscreen. Compartmentation and adequately large joints are required to achieve pressure equalisation.

### Rainscreen

The part of the assembly (normally the outermost) that prevents the majority of rain from penetrating the wall.

Some water may pass through the joints of a rainscreen, but appropriate detailing of open joints or the provision of baffled or labyrinth joints should limit the amount.

### Rainscreen cladding system

A multi-layer façade fixed to the outside face of a building that provides a barrier to wind and rain. The system normally includes a vapour control layer, air barrier, supporting framework and fixings, insulation, breather membrane, cavity/air gap and cladding panels.

Traditional tile hanging and timber cladding are not rainscreen cladding systems as defined in this Chapter.

### Replaceable components

Secondary components are those that can be easily replaced without compromising the design and durability of the building (see Technical Requirement R3), or the need for progressive dismantling of the envelope system. Where this cannot be achieved components should be designed as primary components. A method statement should be provided to demonstrate how components will be replaced with specific reference to accessibility as detailed in clause 6.9 - D4.

### Secondary components

Cladding panels, internal linings, external finishes, window and door furniture, glazing, gaskets, seals and sealant that are easily replaceable.

### Separating floor

A floor that separates flats or rooms for residential purposes.

### Separating wall

A wall that separates adjoining dwelling houses, flats or rooms for residential purposes.

### Slope glazing

A drained and ventilated sloped roofing system.

### Spandrel panel

A panel used in place of glazing units to hide the edges of floor slabs, ceiling details, insulation, and other building elements.

### Test pressures

The pressures at which testing is carried out in accordance with the design.

### Vapour control layer

A layer that restricts the passage of water vapour into the construction to reduce the risk of interstitial condensation.

## DESIGN STANDARDS

### 6.9 - D1 Design shall meet the Technical Requirements

Design that follows the guidance below will be acceptable for curtain walling and cladding.

## STATUTORY REQUIREMENTS

### 6.9 - D2 Design shall comply with all relevant statutory requirements

Design should be in accordance with relevant Building Regulations and other statutory requirements.

## DESIGN LIFE

### 6.9 - D3 Design shall provide satisfactory in-service performance subject to routine inspection and maintenance

Items to be taken into account include:

#### (a) primary components

Primary components should be designed and specified to provide satisfactory in-service performance for the design life of the building. See Technical Requirement R3.

#### (b) secondary components

Secondary components should be designed and specified to provide satisfactory in-service performance for at least 25 years.

## ACCESSIBILITY FOR MAINTENANCE

### 6.9 - D4 Appropriate arrangements shall be provided for the purposes of cleaning, inspection, maintenance and repair

Provision should be made for safe future access to the façade. Access should normally be provided from a safe working platform such as a cradle or mobile elevating platform.

Appropriate arrangements should be made for the replacement of failed insulating glass units without incurring excessive costs for gaining access.

## Curtain walling

## CERTIFICATION

### 6.9 - D5 Curtain walling systems shall be designed and certificated in accordance with appropriate Standards

Curtain walling systems should have certification confirming satisfactory assessment in accordance with the current CWCT Standard for Systemised Building Envelopes by an appropriate independent technical approvals authority accepted by NHBC. The CWCT Standard provides

detailed guidance on performance and testing.

Other certification bodies or test documentation may be acceptable if they are considered by NHBC to be a suitable alternative.

The certification, together with all test documentation should be made available to NHBC before work on the curtain walling or cladding begins on site.

The use of the system should be within the scope of the certification and test documentation.

## IN-SERVICE PERFORMANCE

### 6.9 - D6 Curtain walling systems shall be designed and specified to ensure adequate in-service performance

Items to be taken into account include:

#### (a) loads, movement, brackets and fixings

Dead and live loads should be transferred safely to the building's structure without undue permanent deformation or deflection of any component.

Imposed loads should be calculated in accordance with BS EN 1991-1-1 and BS EN 1991-1-4 and take account of both internal and external pressures, together with the location, shape and size of the building.

Thermal-induced loads due to differential stresses caused by temperature gradients within materials or components should be accommodated without any reduction in performance. The stresses in components and materials should not exceed the permissible values recommended by the product manufacturer.

Movement within the curtain walling should be accommodated without any reduction in performance. Causes of movement include:

- dead and live loads
- changes in temperature
- changes in the moisture content of components
- freezing of retained moisture
- creep.

Fixings and supports should be designed to accommodate specified loads and take account of the product manufacturer's recommendations.

Pull-out or destructive testing of anchors and fixings should be carried out in accordance with the design, BS 5080 and the Construction Fixings Association Guidance Note 'Procedure for Site Testing Construction Fixings'. Tests should be carried out at a suitable rate agreed with NHBC. The test results should be made available to NHBC.

Packing of brackets to achieve surface tolerance should be permitted only in accordance with the product manufacturer's recommendations.

#### (b) insulating glass units

Insulating glass units should be in accordance with Chapter 6.7 'Doors, windows and glazing'.

#### (c) weather resistance

The curtain walling system, including doors, windows and other openings, should resist the passage of water to the inside of the building, allow free drainage and not trap water. It should have:

- external and internal air and water seals, and
- drained and ventilated glazing rebates.

Particular attention should be given to the interfaces between the curtain walling system and other elements or cladding systems.

External and internal air and water seals and a drained ventilated cavity should be provided at all interfaces. Guidance on interfaces is provided in Appendix 6.9-A.

#### (d) air infiltration

Appropriate gaskets and sealants should be used to resist the flow of air from the outside to the interior surface of the curtain walling system. Particular attention should be given to the interfaces between the curtain walling system and the walls, roof, doors, windows and cladding system.

Pre-formed factory-moulded 'picture frame' type vulcanised epdm or silicone internal gaskets should be used for all curtain walling systems.

Sealant should be specified in accordance with BS 6213 and the manufacturer's recommendations.

#### (e) condensation

The curtain walling system should be designed to minimise the risk of surface and interstitial condensation by the use of thermal breaks and a continuous vapour control layer.

Thermal bridging should be controlled to ensure no part of the curtain wall is more at risk of surface condensation forming than the glazing.

#### (f) acoustic performance

Noise from the curtain walling system caused by loads, movements and changes in the environmental conditions should be accommodated without being intrusive.

The curtain walling system should be designed to resist the passage of airborne and impact sound within the building. Particular attention should be given to flanking transmission at:

- the edges of separating floors
- the outer ends of separating walls
- the outer ends of partition walls

- the junctions with roof constructions and parapets.

#### (g) testing

Air and water testing of the 'prototype' curtain walling system should be carried out in accordance with and pass the CWCT Standard (test sequence A or B) tested at a test pressure of 600 Pascals. Panels tested should be of similar size and configuration to those to be used on the building.

Where the maximum calculated design wind pressure is above 2400 Pascals the test pressure should be increased to 0.25 x the design wind pressure.

The 'prototype' should remain watertight during and after the test.

At a test pressure of 600 Pascals an air infiltration rate no higher than 1.5m<sup>3</sup>/hr/m<sup>2</sup> for fixed glazed panels is permissible provided there is no evidence of concentrated leakage.

Wind resistance, serviceability and safety testing should be carried out in accordance with the CWCT Standard.

#### (h) electrical continuity and earth bonding

The curtain walling system should comply with BS 7671 'Requirements for Electrical Installations, formerly IEE Wiring Regulations' and BS EN 62305 'Protection against lightning. General principles'.

#### (i) durability

The curtain walling system should be constructed with corrosion resistant or adequately protected materials. The risk of bimetallic corrosion should be avoided by the isolation of dissimilar metals.

Aluminium components should be separated from direct contact with cementitious surfaces.

The curtain walling system should not include materials liable to infestation attack by micro-organisms, fungi, insects or vermin.

Where timber is used it should be treated in accordance with the guidance in Chapter 2.3 'Timber preservation (natural solid timber)'. Timber should only be used where it can be easily inspected and replaced without disturbing the curtain walling system.

#### (j) tolerances

The design should allow for the line, level, plumb and plane of the completed curtain wall to be within reasonable tolerances. See Chapter 1.2 'A consistent approach to finishes'.



## Rainscreen cladding

### CERTIFICATION

**6.9 - D7 Rainscreen cladding systems shall be designed and certificated in accordance with appropriate Standards**

Rainscreen cladding systems, including panels, should have current certification confirming satisfactory assessment by an appropriate independent technical approvals authority accepted by NHBC, including: British Board of Agrément (BBA) or Building Research Establishment (BRE) Certification.

Systems that are assessed and certificated by an appropriate independent technical approvals organisation in accordance with the CWCT Standard for Systemised Building Envelopes will normally be acceptable to NHBC.

Other certification bodies or test documentation, may be acceptable if they are considered by NHBC to be a suitable alternative.

The certification, together with all test documentation should be made available to NHBC before work on the rainscreen begins on site.

The use of the system should be within the scope of the certification and test documentation.

### IN-SERVICE PERFORMANCE

**6.9 - D8 Rainscreen cladding systems shall be designed and specified to ensure adequate in-service performance**

Items to be taken into account include:

**(a) loads, movement and fixings**

Dead and live loads should be transferred safely to the building's structure without undue permanent deformation or deflection of any component.

Imposed loads should be calculated in accordance with BS EN 1991-1-1 and BS EN 1991-1-4 and take account of the location, shape and size of the building.

Thermal-induced loads due to differential stresses caused by temperature gradients within materials or components should be accommodated without any reduction in performance. The stresses in components and materials should not exceed the permissible values recommended by the product manufacturer.

Movement within the rainscreen cladding should be accommodated without any reduction in performance. Causes of movement include:

- dead and live loads
- changes in temperature
- changes in the moisture content of components

- freezing of retained moisture
- creep.

Fixing rails, frames, fixings and fasteners should be designed to accommodate specified loads and take account of the product manufacturer's recommendations.

Pull-out or destructive testing of anchors and fixings should be carried out in accordance with the design, BS 5080 and the Construction Fixings Association Guidance Note 'Procedure for Site Testing Construction Fixings'. Tests should be carried out at a suitable rate agreed with NHBC. The test results should be made available to NHBC.

Bonded fixings should be specified only where there is no suitable alternative and should be designed in accordance with the product manufacturer's recommendations.

Packing of the supporting rails, frame or the panel fixings to achieve surface tolerance should be permitted only in accordance with the product manufacturer's recommendations.

The air gap between the face of the insulation and the back of the rainscreen panels should be of sufficient width to allow any water passing the joints to run down the back of the rainscreen panels and be discharged externally without wetting the insulation or the backing wall.

The design should avoid the need for disproportionate work when repairing or replacing individual components.

**(b) weather resistance**

The design should ensure that water is prevented from reaching any parts of the wall that could be adversely affected by the presence of moisture.

Sealants should be specified in accordance with BS 6213 and the manufacturer's recommendations.

The minimum width for air gaps should be:

- 50mm for panels with open joints
- 38mm for panels with baffled or labyrinth (rebated) joints.

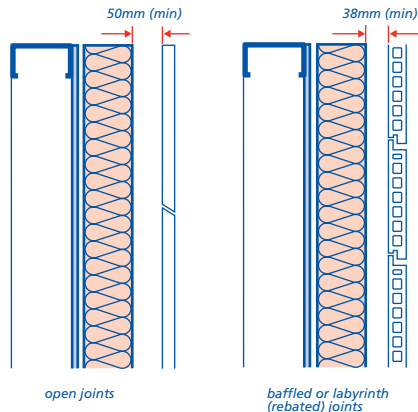

The air gap should be adequately ventilated. Dpc/dpm trays with stop ends should be provided above openings, at the base of the rainscreen and at interfaces where necessary, to ensure water is drained to the outside.

Particular attention should be given to the interface between the rainscreen cladding system and the walls, roof, doors, windows, other cladding systems, and curtain walling. External and internal air and water seals should be provided at all interfaces. Guidance on interfaces is provided in Appendix 6.9-A.

Open, baffled or labyrinth (rebated) joints should normally have a minimum opening of 10mm.

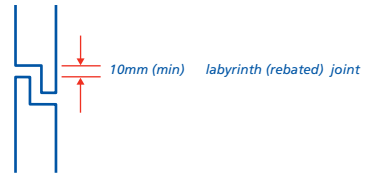
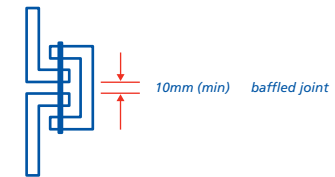
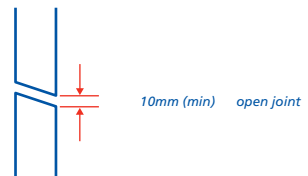

A screen to prevent birds and animals entering the cavity should be provided at the top and bottom of the rainscreen and penetrations through the cladding.

**(c) insulation**

Where insulation forms part of the rainscreen cladding system it should cover all exposed areas of the backing wall, be neatly cut around fixings and brackets and be fixed in accordance with the product manufacturer's recommendations.



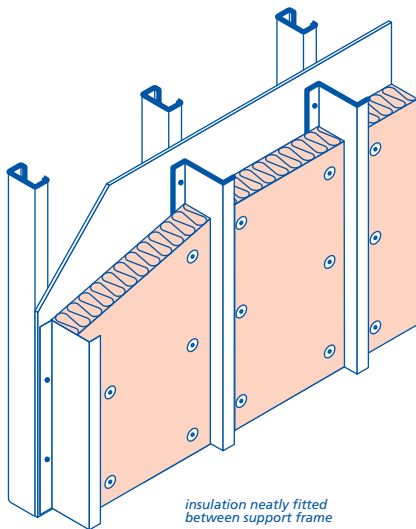

Where the insulation is fixed to the backing wall a minimum of one non-combustible fixing per square metre or per insulation batt, whichever is the lesser, should be provided in addition to the other fixings.

Reference should be made to BRE document BR135 - 2003 'Fire performance of external thermal insulation for walls of multi-storey buildings' when specifying the type of insulation system to be installed.

The design should ensure that the insulation is continuous around penetrations through the rainscreen cladding system.

Where the rainscreen panel joints are open and the performance of the insulation could be diminished by moisture, a breather membrane should be provided over the outer face of the insulation.

#### (d) thermal bridging and condensation

The rainscreen cladding system should be designed to minimise the risk of thermal bridging and, surface and interstitial condensation.

A vapour control layer should be provided unless a condensation risk analysis in accordance with BS 5250 shows that one is not necessary. The vapour control layer should be fixed on the warm side of the wall insulation.

#### (e) air infiltration

The rainscreen cladding system should be fixed to a backing wall that is reasonably airtight, e.g.

- masonry walls jointed to a high standard with all joints filled
- framed walls with a rigid sheathing on the cavity face with all joints taped or sealed.

Where reasonable airtightness cannot be achieved, a separate continuous vapour permeable air barrier with joints taped or sealed should be provided on the outer face of the backing wall.

#### (f) compartmentation

A rainscreen cladding system that has open joints between the panels should be designed as a pressure equalised system.

The cavity should be compartmented by:

- a horizontal cavity closer at each floor level, and
- vertical cavity closers at centres not exceeding 6.0m,
- vertical cavity closers at centres not exceeding 1.5m within 6.0m of an internal or external corner, and
- a vertical cavity closer as close as possible to an external corner, normally within 300mm.

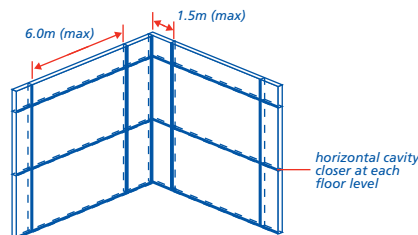

This compartmentation is in addition to the requirements of the Building Regulations for cavity barriers to control the spread of smoke and fire. However, the same cavity barriers may be used for the compartmentation.

#### (g) acoustic performance

Noise from the rainscreen cladding system caused by rain striking the outer surface of panels should be accommodated without being intrusive e.g. by the use of noise absorbing or anti-drumming material.

#### (h) electrical continuity and earth bonding

The rainscreen cladding system should comply with BS 7671 'Requirements for Electrical Installations, formerly IEE Wiring Regulations' and BS EN 62305 'Protection against lightning. General principles'.

#### (i) durability

The rainscreen cladding system should be designed with corrosion resistant, adequately protected or durable materials.

Fixings and bracketry should normally be stainless steel or a suitable non-ferrous metal.

The risk of bimetallic corrosion should be avoided by the isolation of dissimilar metals.

Aluminium components should be separated from direct contact with cementitious surfaces.

The rainscreen cladding system should not include materials liable to infestation attack by micro-organisms, fungi, insects or vermin.

#### (j) tolerances

The design should allow for the line, level, plumb and plane of the completed

rainscreen cladding system to be within reasonable tolerances for the materials involved. See Chapter 1.2 'A consistent approach to finishes'.

## Insulated render systems

### CERTIFICATION

**6.9 - D9 Insulated render systems shall be designed and certificated in accordance with appropriate Standards**

Insulated render systems should have current certification confirming satisfactory assessment by an appropriate independent technical approvals authority accepted by NHBC, including: British Board of Agrément (BBA) or Building Research Establishment (BRE) Certification.

### IN-SERVICE PERFORMANCE

**6.9 - D10 Insulated render systems shall be designed and specified to ensure adequate in-service performance**

Items to be taken into account include:

#### (a) loads, movement and fixings

Dead and live loads should be transferred safely to the building's structure without undue permanent deformation or deflection of any component.

Imposed loads should be calculated in accordance with BS EN 1991-1-1 and BS EN 1991-1-4 and take account of the location, shape and size of the building.

Thermal-induced loads due to differential stresses caused by temperature gradients within materials or components should be accommodated without any reduction in performance. The stresses in components and materials should not exceed the permissible values recommended by the manufacturer.

Movement within the insulated render system should be accommodated without any reduction in performance. Causes of movement include:

- dead and live loads
- changes in temperature
- changes in the moisture content of components
- freezing of retained moisture
- creep.

Movement joints in the backing wall should be continued through the insulated render system and formed in accordance with the manufacturer's recommendations.

Fixing rails, frames, mechanical and bonded fixings should be designed to accommodate specified loads and take account of the manufacturer's recommendations.

Pull-out or destructive testing of anchors and fixings should be carried out in

# 6.9 Curtain walling and cladding

accordance with the design, BS 5080 and the Construction Fixings Association Guidance Note 'Procedure for Site Testing Construction Fixings'. Tests should be carried out at a suitable rate agreed with NHBC. The test results should be made available to NHBC.

## (b) weather resistance

Insulated render systems, together with the backing wall to which they are applied, should satisfactorily resist the passage of moisture to the inside of the building.

For timber and steel framed backing walls a cavity of at least 15mm should be provided between the wall and the insulation to allow any moisture to drain away.

Where the backing wall is timber framed the cavity should be ventilated in accordance with Chapter 6.2 'External timber framed walls' (Design).

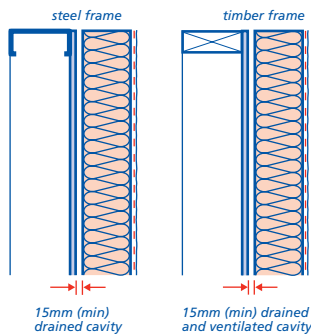

The introduction of a cavity is likely to increase the risk of impact damage to vulnerable areas of the insulated render system, e.g. at low level, around balconies and where cradle systems, etc. can come into contact with the façade. Suitable precautions to resist impact damage should be included in the design e.g. by the provision of a rigid board behind the insulation whilst maintaining the cavity.

Dpc/dpm trays with stop ends should be provided above openings, above cavity barriers, at the base of the insulated render system and at interfaces where necessary to ensure water is drained to the outside. The insulated render support system should not obstruct the drainage paths.

Insulated render systems can be applied direct to concrete panels or masonry backing walls without a cavity being provided.

Particular attention should be given to the interfaces between the insulated render system and the walls, roof, doors, windows, other cladding systems and curtain walling. Guidance on interfaces is provided in Appendix 6.9-A.

Sealants and tapes should be specified in accordance with BS 6213 and the manufacturer's recommendations.

Where appropriate, a screen to prevent birds and animals entering the cavity should be provided at the top and bottom of the cavity and to penetrations through the cladding.

## (c) insulation

The insulation type should be suitable for the intended purpose and be appropriately keyed to receive the render finish.

The insulated render system should be securely fixed to the support frame or backing wall with appropriate fixings/adhesive in accordance with the manufacturer's recommendations.

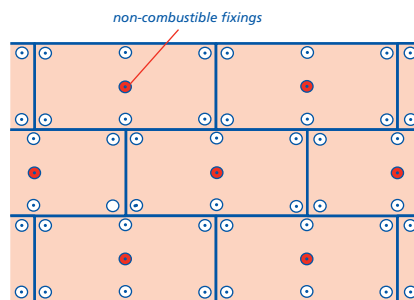

A minimum of one non-combustible fixing per square metre or per insulation batt, whichever provides the greater number, should be provided in addition to the other fixings. The non-combustible fixings should be fixed through the mesh reinforcement.

Reference should be made to BRE document BR135 - 2003 'Fire performance of external thermal insulation for walls of multi-storey buildings' when specifying the type of insulation system to be installed.

The design should ensure the continuity of insulation around openings and other penetrations.

## (d) thermal bridging and condensation

The insulated render system should be designed to minimise the risk of thermal bridging and surface and interstitial condensation.

A condensation risk analysis in accordance with BS 5250 should be carried out. Unless it shows otherwise, a vapour control layer should be provided. The vapour control layer should be fixed on the warm side of the wall insulation.

## (e) reinforcement

Reinforcement mesh should be included in the design in accordance with the manufacturer's recommendations. Typically, reinforcement mesh should also be provided at points where there is a likelihood of increased stress in the render system, e.g. at the corners of window or door openings.

Appropriate trims should be provided at openings, corners, angles, interfaces and movement joints in accordance with the manufacturer's recommendations.

## (f) render

Proprietary render systems should be specified in accordance with the manufacturer's recommendations and include the correct number and thickness of render coats.

Corners, returns and features should be formed with appropriate trims in accordance with the manufacturer's recommendations.

## (g) durability

The insulated render system should be designed with corrosion resistant or adequately protected materials.

Fixings and bracketry should normally be stainless steel, suitable non-ferrous metal or suitable plastics.

The risk of bimetallic corrosion should be avoided by the isolation of dissimilar metals.

The insulated render system should not include materials liable to infestation attack by micro-organisms, fungi, insects or vermin.

## (h) tolerances

The design should allow for the line, level, plumb and plane of the completed insulated render system to be within reasonable tolerances for the materials involved. See Chapter 1.2 'A consistent approach to finishes'.

## Brick slip cladding systems

### CERTIFICATION

**6.9 - D11 Brick slip cladding systems shall be designed and certificated in accordance with appropriate Standards**

Brick slip cladding systems should have current certification confirming satisfactory assessment by an appropriate technical approvals authority accepted by NHBC, including: British Board of Agrément (BBA) or Building Research Establishment (BRE) Certification.

### IN-SERVICE PERFORMANCE

**6.9 - D12 Brick slip cladding systems shall be designed and specified to ensure adequate in-service performance**

Items to be taken into account include:

#### (a) loads, movement and fixings

Dead and live loads should be transferred safely to the building's structure without undue permanent deformation or deflection of any component.

Imposed loads should be calculated in accordance with BS EN 1991-1-1 and BS EN 1991-1-4 and take account of the location, shape and size of the building.

Thermal-induced loads due to differential stresses caused by temperature gradients within materials or components should be accommodated without any reduction in performance. The stresses in components and materials should not exceed permissible values recommended by the manufacturer.

Movement within the brick slip system should be accommodated without any reduction in performance. Causes of movement include:

- dead and live loads
- changes in temperature
- changes in the moisture content of components
- freezing of retained moisture
- creep.

Movement joints in the backing wall should be continued through the brick slip cladding system and formed in accordance with the manufacturer's recommendations.

Fixing rails, frames, fixings and fasteners should be designed to accommodate specified loads and take account of the manufacturer's recommendations.

Bonded fixings of rails, frames, fixings and fasteners should be specified only where there is no suitable alternative and should be designed in accordance with the manufacturer's recommendations.

Pull-out or destructive testing of anchors and fixings should be carried out in accordance with the design, BS 5080 and the Construction Fixings Association Guidance Note 'Procedure for Site Testing Construction Fixings'. Tests should be carried out at a suitable rate agreed with NHBC. The test results should be made available to NHBC.

### (b) weather resistance

Brick slip cladding systems, together with the backing wall to which they are applied, should satisfactorily resist the passage of moisture.

For timber and steel framed backing walls a cavity of at least 15mm should be provided between the wall and the brick slip cladding system to allow any moisture to drain away.

Where the backing wall is timber framed the cavity should be ventilated in accordance with Chapter 6.2 'External timber framed walls' (Design).

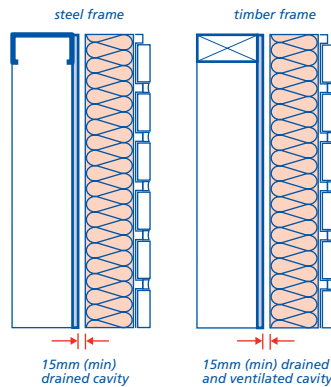

The introduction of a cavity is likely to increase the risk of impact damage to vulnerable areas of the brick slip cladding system, e.g. at low level, around balconies and where cradle systems, etc. can come into contact with the façade. Suitable precautions to resist impact damage should be included in the design e.g. by the provision of a rigid board behind the insulation whilst maintaining the cavity.

Dpc/dpm trays with stop ends should be provided above openings, above cavity barriers, at the base of the brick slip cladding system and at interfaces where necessary to ensure water is drained to the outside. The brick slip support system should not obstruct the drainage paths.

Brick slip cladding systems can be applied direct to concrete panels or masonry backing walls without a cavity being provided.

Particular attention should be given to the interfaces between the brick slip cladding system and the walls, roof, doors, windows, other cladding systems and curtain walling. Guidance on interfaces is provided in Appendix 6.9-A.

Sealants should be specified in accordance with BS 6213 and the manufacturer's recommendations.

Where appropriate a screen to prevent birds and animals entering the cavity should be provided at the top and bottom of the cavity and to penetrations through the cladding.

### (c) insulation

Insulation forming an integral part of the brick slip cladding system should be specified and fixed with appropriate fixings/adhesive in accordance with the manufacturer's recommendations.

Other insulation included in the design should be suitable for its intended purpose and be specified and fixed with appropriate fixings/adhesive in accordance with the manufacturer's recommendations.

A minimum of one non-combustible fixing per square metre or per insulation batt, whichever is the lesser, should be provided in addition to the other fixings.

Reference should be made to BRE document BR135 - 2003 'Fire performance of external thermal insulation for walls of multi-storey buildings' when specifying the type of insulation system to be installed.

The design should ensure the continuity of insulation around openings and other penetrations.

### (d) thermal bridging and condensation

The brick slip cladding system should be designed to minimise the risk of thermal bridging and surface and interstitial condensation.

A vapour control layer should be provided unless a condensation risk analysis in accordance with BS 5250 shows that one is not necessary. The vapour control layer should be fixed on the warm side of the wall insulation.

### (e) carriers

Proprietary carriers forming an integral part of the brick slip cladding system should be fixed with appropriate fixings/adhesive in accordance with the manufacturer's recommendations.

### (f) brick slips

Brick slips should be specified and fixed in accordance with the system manufacturer's recommendations.

The design should ensure that excessive cutting of brick slips is avoided, e.g. in the storey heights, at corners and around openings. Coursing should be arranged to suit lintel heights.

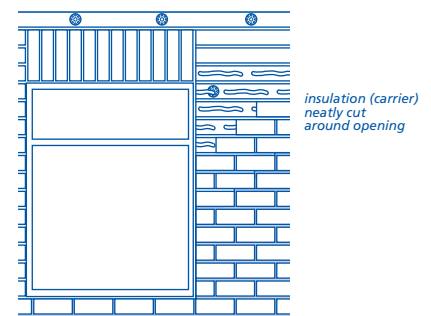

### (g) joints

Mortars, proprietary mortars and grouts should be specified in accordance with the system manufacturer's recommendations to enable each joint to be adequately filled and appropriately struck.

### (h) durability

Fixings for the brick slip cladding system should be corrosion resistant or adequately protected materials.

Fixings and bracketry should normally be stainless steel, suitable non-ferrous metal or appropriate plastics.

The risk of bimetallic corrosion should be avoided by the isolation of dissimilar metals.

# 6.9

## Curtain walling and cladding

The brick slip cladding system should not include materials liable to infestation attack by micro-organisms, fungi, insects or vermin.

### (i) tolerances

The design should allow for the line, level, plumb and plane of the completed brick slip cladding system to be within reasonable tolerances for the materials involved. See Chapter 1.2 'A consistent approach to finishes'.

## General

### PROVISION OF INFORMATION

**6.9 - D13 Designs and specifications shall be produced in a clearly understandable format and include all relevant information**

Drawings and specifications should include:

- full set of drawings
- schedule of revisions
- manufacturer's specification
- fixing schedules
- specific details of all interfaces
- manufacturer's recommendations relating to proprietary items
- on-site testing regime.

**6.9 - D14 All relevant information shall be distributed to appropriate personnel**

Ensure that design and specification information is issued to site supervisors and relevant specialist subcontractors and/or suppliers.

Manufacturers' requirements for installation and fixing should be made available for reference on site to ensure work is carried out in accordance with the design and specification.

All relevant information in a form suitable for the use of site operatives should be available on site before work on the curtain walling or cladding starts.

## MATERIALS STANDARDS

**6.9 - M1 All materials shall:**

- (a) meet the technical requirements**
- (b) take account of the design**

Materials that comply with the design and the guidance below will be acceptable for curtain walling, rainscreen cladding, insulated render and brick slip cladding systems.

Materials for curtain walling, rainscreen cladding, insulated render and brick slip cladding systems should comply with all relevant standards, including those listed below. Where no standard exists, Technical Requirement R3 applies (see Chapter 1.1 'Introduction to the Standards and Technical Requirements').

References to British Standards and Codes of Practice include those made under the Construction Products Directive (89/106/EEC) and, in particular, appropriate European Technical Specifications approved by a European Committee for Standardisation (CEN).

### DPC/DPM MATERIALS

**6.9 - M2 Materials for damp-proofing shall resist adequately the passage of moisture**

Items to be taken into account include:

#### (a) dpcs/dpms

The following materials are acceptable for use as dpcs/dpms:

- polyethylene to BS 6515
- EPDM
- neoprene
- proprietary materials assessed in accordance with Technical Requirement R3.

Materials for dpcs/dpms should be compatible with adjoining materials.

Dpcs/dpms and flexible cavity trays should be of the correct dimensions to suit the detailed design.

For complicated junctions, preformed cavity trays are recommended.

#### (b) flashings

The following are acceptable as flashings:

- rolled lead sheet (at least code 4) complying with BS EN 12588
- aluminium and aluminium alloys to BS EN 485 and BS EN 573
- zinc alloys to BS EN 988
- stainless steel.

Aluminium and aluminium alloys should not come into contact with cementitious material.

### GLAZING

**6.9 - M3 Glazing shall be as required by the design**

Reference should be made to Chapter 6.7 'Doors, windows and glazing' (each section) for guidance on glazing.

### GASKETS

**6.9 - M4 Materials for gaskets shall provide satisfactory performance**

Extruded rubber gaskets should comply with BS 4255.

Other materials may be used if satisfactorily assessed in accordance with Technical Requirement R3.

### SEALANT

**6.9 - M5 Materials for sealant shall provide satisfactory performance**

Sealant should be selected and applied in accordance with BS 6213 and BS EN ISO 11600.

Sealant to be used in locations where differential movement may be expected, e.g. interfaces between the façade and the structure, should be one of the following:

- two part polysulphide
- one part polysulphide
- one part silicone
- one or two part polyurethane.

Other materials may be used if satisfactorily assessed in accordance with Technical Requirement R3.

### THERMAL INSULATION

**6.9 - M6 Insulation materials shall provide the degree of insulation to comply with the design**

Insulation materials should be inert, durable, rot and vermin proof and should not be adversely affected by moisture or vapour.

Insulation materials that comply with the following Standards are acceptable:

- mineral wool to BS EN 13162
- FR grade (flame retardant) expanded polystyrene to BS EN 13163
- FR grade (flame retardant) extruded polystyrene to BS EN 13164
- rigid polyurethane foam and polyisocyanurate to BS EN 13165
- phenolic foam to BS EN 13166
- cellular glass to BS EN 13167.

Other materials may be used if satisfactorily assessed in accordance with Technical Requirement R3.

### BREATHER MEMBRANES

**6.9 - M7 Breather membranes shall be durable and be capable of allowing water vapour to pass outwards and prevent moisture from penetrating inwards**

Breather membranes should comply with BS 4016 (Type 1 in areas of very severe exposure).

Other materials may be used if satisfactorily assessed in accordance with Technical Requirement R3.

### CAVITY BARRIERS AND FIRE-STOPS

**6.9 - M8 Materials used for cavity barriers and fire-stops shall be capable of providing adequate resistance to fire and smoke**

Materials specified in statutory requirements are acceptable.

Other materials may be used if satisfactorily assessed in accordance with Technical Requirement R3.



Systems incorporating proprietary intumescent materials should follow the guidance provided by The Intumescent Fire Seals Association (IFSA) and the Association for Specialist Fire Protection (ASFP).

## FIXINGS

**6.9 - M9 Fixings shall be of durable material and provide satisfactory performance**

Fixings should be manufactured from:

- phosphor bronze
- silicon bronze
- stainless steel to BS EN ISO 3506
- mild steel with coatings to BS EN 12329, BS EN 12330, BS EN 1461, or other appropriate treatment in accordance with BS EN ISO 12944 or BS EN ISO 14713
- aluminium alloy to BS EN 573 and BS EN 755
- appropriate plastics.

Materials that comply with recognised Standards, which provide equal or better performance to those above, would also be acceptable.

Other materials may be used if satisfactorily assessed in accordance with Technical Requirement R3.

Aluminium and aluminium alloys should not come into contact with cementitious material.

## TIMBER PRESERVATION

**6.9 - M10 Timber shall be either naturally durable or preservative treated to provide adequate protection against rot and insect attack**

Reference should be made to Chapter 2.3 'Timber preservation (natural solid timber)' (each section) for guidance on preservative treatments.

## VENTILATION SCREENS

**6.9 - M11 Ventilation openings shall be protected from the entry of birds and animals**

Ventilation openings where the least dimension exceeds 10mm should be protected to prevent the entry of birds and animals.

Acceptable protection of openings can be provided by:

- rigid fabrications with width of opening greater than 3mm and less than 10mm (no restriction on length)
- rigid fabrications with round holes greater than 3mm and less than 10mm diameter
- square or rectangular mesh where the clear opening size is greater than 3mm and less than 10mm.

## SITWORK STANDARDS

**6.9 - S1 All sitework shall:**  
**(a) meet the Technical Requirements**  
**(b) take account of the design**  
**(c) follow established good practice and workmanship**

Sitework that complies with the design and guidance below will be acceptable for curtain walling and cladding systems.

All relevant information in a form suitable for the use of site operatives should be available on site before work on the curtain walling or cladding system starts, including:

- full set of drawings
- schedule of revisions
- manufacturer's specification
- fixing schedules
- specific details of all interfaces
- manufacturer's recommendations relating to proprietary items
- on-site testing regime.

**6.9 - S2 Curtain walling and cladding systems shall be installed by competent operatives**

Curtain walling, rainscreen cladding, insulated render and brick slip cladding systems should be installed by operatives who:

- are competent
- are familiar with the system being installed
- hold a certificate confirming they have been trained by the system manufacturer, supplier or installer.

## HANDLING AND STORAGE

**6.9 - S3 Materials, products and systems shall be protected and stored in a satisfactory manner to prevent damage, distortion, uneven weathering and degradation**

Items to be taken into account include:

**(a) handling and storage**

The curtain walling or cladding system should be transported, lifted, handled and stored in accordance with the manufacturer's recommendations.

Insulated glass units should be carefully stored and protected in a sheltered dry area.

**(b) protection**

All practical steps should be taken to avoid the risk of damage to the curtain walling or cladding system during construction.

## Curtain walling

### LOCATION AND FIXING

**6.9 - S4 Curtain walling systems shall be correctly located and securely fixed in accordance with the design**

Curtain walling systems should be correctly located and securely fixed in accordance with the manufacturer's specification and the design details.

The type, size and positioning of all fixings should be in accordance with the design.

Proprietary fixings should be used in accordance with the manufacturer's recommendations with particular attention given to:

- the correct embedment, spacing and edge distances
- correct torque settings
- the provision of suitable locking nuts and washers
- the isolation of dissimilar metals
- the isolation of aluminium from cementitious material.

## WEATHER RESISTANCE

**6.9 - S5 Curtain walling systems shall be correctly installed to prevent moisture entering the building**

Items to be taken into account include:

**(a) weathertightness**

Curtain walling systems including doors, windows and other components should be installed correctly to ensure satisfactory in-service performance.

**(b) gaskets and sealants**

Appropriate gaskets and sealants should be installed and used to ensure satisfactory performance. Gaskets and sealants should be used in accordance with the design and the manufacturer's recommendations.

Pre-formed factory-moulded 'picture frame' type vulcanised epdm or silicone internal gaskets should be used.

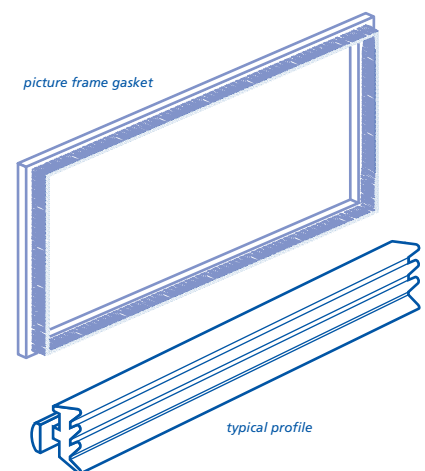

External and internal air and water seals and a drained cavity should be provided at all interfaces. Guidance on interfaces is provided in Appendix 6.9-A.

**(c) dpccs/dpms**

Dpccs/dpms should be installed correctly to provide a physical barrier to the passage of moisture. Dpc/dpm arrangements which

# 6.9 Curtain walling and cladding

rely solely on sealant should not be used. Guidance on the use of dpcs/dpms at interfaces is provided in Appendix 6.9-A.

Dpc/dpm arrangements should extend the full height of the curtain walling system and have appropriate details at all interfaces including floors, walls, roofs, balconies and terraces, to ensure moisture is directed to the outside.

### (d) opening doors and lights

Opening doors and lights should be fitted in accordance with the design, hang square within the curtain wall frame and fit neatly with minimum gaps to ensure effective weatherproofing.

## GLAZING

### 6.9 - S6 Glazing shall be carried out in accordance with relevant standards

Glazing should be carried out in accordance with Chapter 6.7 'Doors, windows and glazing' (Design and Sitework).

## CONTROL OF CONDENSATION

### 6.9 - S7 Installation shall ensure that the risk of condensation is minimised

Insulation should be installed in accordance with the design, ensuring that all interfaces are adequately insulated.

A continuous, durable vapour control layer should be provided in accordance with the design.

## ALLOWANCE FOR MOVEMENT

### 6.9 - S8 Installation shall allow movement of the curtain walling system and the building without causing damage or deformation

Allowance for movement should be provided in accordance with the design.

## TOLERANCES

### 6.9 - S9 Installation shall achieve the design tolerances

The line, level, plumb and plane of the completed curtain walling system should be in accordance with the design. See Chapter 1.2 'A consistent approach to finishes'.

## TESTING

### 6.9 - S10 Site hose testing shall be carried out on the curtain walling system to confirm satisfactory performance

On-site testing should be carried out to determine the resistance to water penetration of the curtain walling system,

including all joints and interfaces which are designed to be permanently closed and watertight.

Representative samples of the finished installation should be hose tested on site in accordance with the current CWCT Standard for curtain walling.

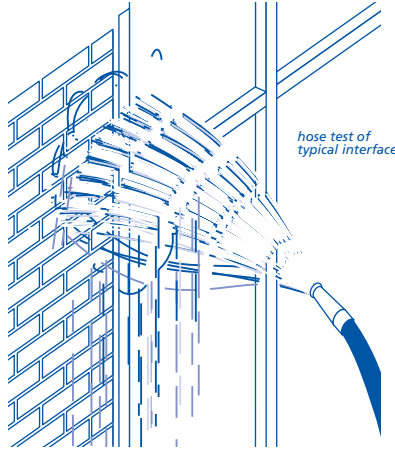

At least 5% of the completed curtain walling system should be tested, with particular focus on vulnerable areas such as joints and interfaces.

Other testing may be acceptable if it is considered by NHBC to be a suitable alternative.

The results of all testing should be made available to NHBC.

## Rainscreen cladding

### LOCATION AND FIXING

#### 6.9 - S11 Rainscreen cladding systems shall be correctly located and securely fixed in accordance with the design

Rainscreen cladding systems should be correctly located and securely fixed in accordance with the manufacturer's specification and the design details.

The type, size and positioning of all anchors, fixing rails, frames, fixings and fasteners should be in accordance with the design.

Bonded fixings should only be used in accordance with the design.

Anchors, fixings and bracketry should normally be stainless steel or a suitable non-ferrous metal.

Proprietary fixings should be used in accordance with the manufacturer's recommendations with particular attention given to:

- the correct embedment, spacing and edge distances
- correct torque levels
- the provision of suitable locking nuts and washers
- the isolation of dissimilar metals

- the isolation of aluminium from cementitious material.

## WEATHER RESISTANCE

### 6.9 - S12 Rainscreen cladding systems shall be correctly installed to prevent moisture entering the building

Items to be taken into account include:

#### (a) weathertightness

Rainscreen cladding systems including door, window and other openings and cover flashings, should be installed correctly to ensure satisfactory in-service performance.

Installation should prevent water reaching any parts of the wall that could be adversely affected by the presence of moisture.

The following minimum air gap should be maintained behind all rainscreen panels:

- 50mm for panels with open joints, or
- 38mm for panels with baffle or labyrinth (rebated) joints.

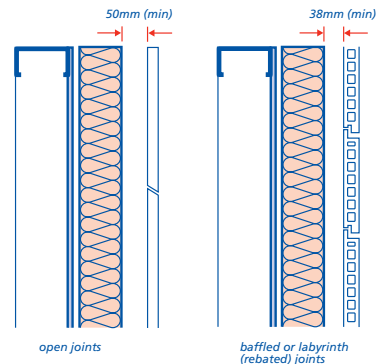

Unless specified otherwise in the design, all open, baffled or labyrinth (rebated) joints should have a minimum opening of 10mm.

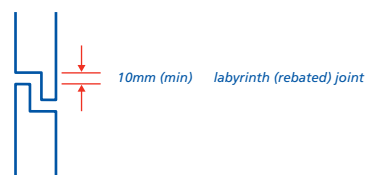
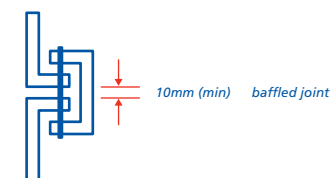
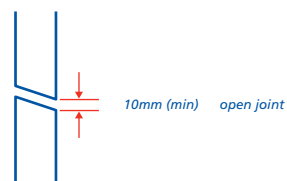

Where required by the design a screen to prevent birds and animals entering

the cavity should be provided at the top and bottom of the rainscreen and to penetrations through the cladding.

Where required by the design, dpcs/dpms should be installed correctly to provide a physical barrier to the passage of moisture. Dpc/dpm arrangements which rely solely on sealant should not be used.

To ensure moisture is directed to the outside, dpc/dpm arrangements should be correctly formed with suitable upstands and stop ends including at the junction between the rainscreen cladding and any other component or system. External and internal air and water seals and a drained cavity should be provided at all interfaces. Guidance on interfaces is provided in Appendix 6.9-A.

Appropriate sealants should be used in accordance with the design and the manufacturer's recommendations to ensure satisfactory performance.

#### (b) insulation and condensation

Where insulation forms part of the rainscreen, it should be installed in accordance with the design and the manufacturer's recommendations, ensuring that all parts of the backing wall are adequately insulated.

Where the rainscreen panel joints are open and the insulation could be adversely affected by the presence of water, a continuous durable breather membrane should be provided to the outer face of the insulation.

Where the insulation is fixed to the backing wall, a minimum of one non-combustible fixing per square metre or per batt, whichever is the lesser, should be provided in addition to the other fixings.

Installation should ensure that the insulation is continuous around penetrations through the rainscreen.

The rainscreen cladding system should be installed to minimise the risk of thermal bridging and surface and interstitial condensation.

#### (c) air infiltration

The rainscreen cladding system should be fixed to a backing wall that is reasonably airtight, e.g:

- masonry walls jointed to a high standard with all joints filled
- framed walls with a rigid sheathing on the cavity face with all joints taped or sealed.

Where reasonable airtightness cannot be achieved, a separate continuous vapour permeable air barrier with joints taped or sealed should be provided on the outer face of the backing wall.

#### (d) compartmentation

To help achieve pressure equalisation in open jointed rainscreen cladding systems, the cavity should be compartmented by:

- a horizontal cavity closer at each floor level, and
- vertical cavity closers at centres not exceeding 6.0m, and
- vertical cavity closers at centres not exceeding 1.5m in the area within 6.0m of an internal or external corner, and
- a vertical cavity closer as close as possible to an external corner, normally within 300mm.

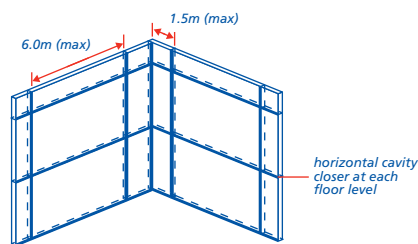

This compartmentation is in addition to the requirements of the Building Regulations for cavity barriers to control the spread of smoke and fire. However, the same cavity barriers may be used for the compartmentation.

Cavity closers should be rigid and be installed in accordance with the manufacturer's recommendations with particular attention given to maintaining ventilation and drainage in accordance with the design.

#### (e) durability

The rainscreen cladding system should be fabricated and installed with corrosion resistant or adequately protected materials.

Fixings and bracketry should normally be stainless steel or suitable non-ferrous metal.

The risk of bimetallic corrosion should be avoided by the isolation of dissimilar metals.

Aluminium components should be separated from direct contact with cementitious surfaces.

The rainscreen cladding system should not include materials liable to infestation attack by micro-organisms, fungi, insects or vermin.

#### (f) testing

On-site hose or sparge bar testing should be carried out with particular emphasis on interfaces that are designed to be permanently closed and watertight.

The building should remain watertight during and after the test.

## ALLOWANCE FOR MOVEMENT

**6.9 - S13 Installation shall allow movement of the rainscreen cladding system and the building without causing damage or deformation**

Allowance for movement e.g. at interfaces and at gaps between panels, should be provided in accordance with the design.

## TOLERANCES

**6.9 - S14 Installation shall achieve the design tolerances**

Installation should allow for the line, level, plumb and plane of the completed rainscreen cladding system to be within reasonable tolerances for the materials involved. See Chapter 1.2 'A consistent approach to finishes'.

## Insulated Render Systems

### FIXING

**6.9 - S15 Insulated render systems shall be securely fixed in accordance with the design**

Insulated render systems should be securely fixed in accordance with the design and the manufacturer's recommendations.

The type, size and positioning of all anchors, fixing rails, frames, fixings, fasteners and bonded joints should be in accordance with the design.

Anchors, fixings and bracketry should normally be stainless steel, suitable non-ferrous metal or appropriate plastics.

For mechanically-fixed systems particular attention should be given to:

- correct embedment, spacing and edge distances
- correct torque settings
- provision of suitable locking nuts and washers
- the isolation of dissimilar metals
- the isolation of aluminium from cementitious material.

For adhesive-fixed systems particular attention should be given to:

- thorough assessment of the backing wall to confirm adhesive fixing is suitable
- suitable preparation of the backing wall to receive the adhesive
- the provision of supplementary mechanical fixings as required by the design.

## WEATHER RESISTANCE

**6.9 - S16 Insulated render systems shall be correctly installed to prevent moisture entering the building**

Items to be taken into account include:



# 6.9 Curtain walling and cladding

## (a) weathertightness

Insulated render systems should be installed correctly to ensure satisfactory in-service performance.

Insulated render systems should prevent water reaching any parts of the wall that could be adversely affected by the presence of moisture.

Where the backing wall is timber or steel framed a cavity of at least 15mm should be provided between the wall and the insulation to allow moisture to drain away.

Where the backing wall is timber framed the cavity should be ventilated in accordance with Chapter 6.2 'External timber framed walls' (Design).

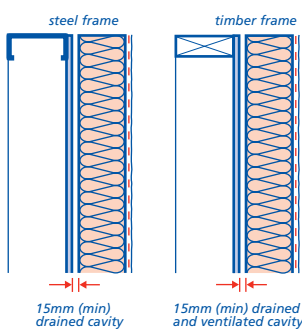

Suitable precautions to resist impact damage should be provided in accordance with the design.

Where required by the design a screen should be provided to prevent birds and animals entering the cavity through the ventilation and drainage openings.

Insulated render systems can be applied direct to masonry backing walls without a cavity being provided.

Where required by the design, dpcs/dpms should be installed correctly to provide a physical barrier to the passage of moisture. Dpc/dpm arrangements which rely solely on sealant should not be used.

To ensure moisture is directed to the outside, dpc/dpm arrangements should be correctly formed with suitable upstands and stop ends including at the junction between the insulated render system and any other component or system.

Guidance on interfaces is provided in Appendix 6.9-A.

Appropriate tapes and sealant should be used in accordance with the design and the manufacturer's recommendations to ensure satisfactory performance.

## (b) insulation and condensation

Insulation should be installed in accordance with the design and the manufacturer's recommendations, ensuring that all parts of the backing wall are adequately insulated.

Insulation should be returned into window and door openings and be continuous around penetrations through the wall.

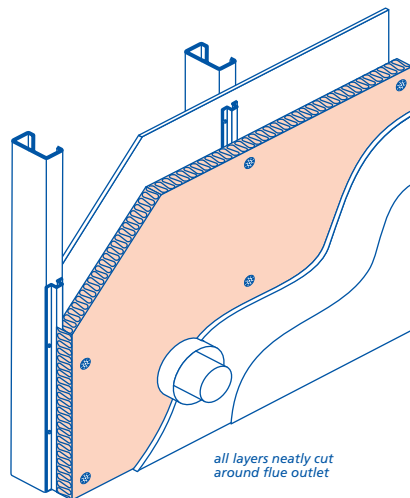

## (c) air infiltration

The backing wall should be reasonably airtight before installation of the insulated render system, e.g.

- masonry walls jointed to a high standard with all joints etc filled
- framed walls with a rigid sheathing on the cavity face with all joints taped and sealed.

## (d) reinforcement

Reinforcement mesh should be provided in accordance with the design taking account of the following:

- laps between sheets of reinforcement mesh should be not less than 100mm
- openings, corners, angles, interfaces and movement joints should be formed with appropriate trims
- additional mesh should normally be provided at points where there is a likelihood of increased stress in the render system, e.g. at the corners of window and door openings
- movement joints in the backing wall should continue through the insulated render system.

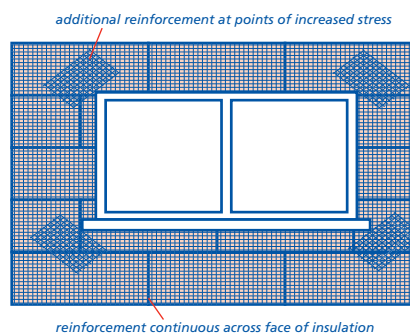

## (e) render

The surface to be rendered should be free from contamination, dust and loose particles. The number and thickness of coats should be in accordance with the design.

Where coloured pigments are specified, batching should be undertaken with care to ensure colour consistency.

## TOLERANCES

### 6.9 - S17 Installation shall achieve the design tolerances

Installation should allow for the line, level, plumb and plane of the completed insulated render system to be within reasonable tolerances for the materials involved. See Chapter 1.2 'A consistent approach to finishes'.

## Brick Slip Cladding Systems

## FIXING

### 6.9 - S18 Brick slip cladding systems shall be securely fixed in accordance with the design

Brick slip cladding systems should be securely fixed in accordance with the design and the manufacturer's recommendations.

The type, size and positioning of all anchors, fixing rails, frames, fixings, fasteners and bonded joints should be in accordance with the design.

Anchors, fixings and bracketry should normally be stainless steel, suitable non-ferrous metal or appropriate plastics.

Particular attention should be given to:

- correct embedment, spacing and edge distances
- correct torque levels
- provision of suitable locking nuts and washers
- the isolation of dissimilar metals
- the isolation of aluminium from cementitious material.

Fixing systems should be accurately set out to ensure brick slips suit storey heights, lintels, corners and openings.

## WEATHER RESISTANCE

### 6.9 - S19 Brick slip cladding systems shall be correctly installed to prevent moisture entering the building

Items to be taken into account include:

#### (a) weathertightness

Brick slip cladding systems should be installed correctly to ensure satisfactory in-service performance.

The brick slip cladding system should prevent water reaching any parts of the wall that could be adversely affected by the presence of moisture.

Where the backing wall is timber or steel framed, a cavity of at least 15mm should be provided between the wall and the insulation to allow moisture to drain away.

Where the backing wall is timber framed, the cavity should be ventilated in accordance with Chapter 6.2 'External timber framed walls' (Design).

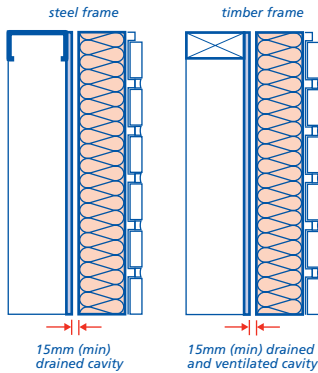

Suitable precautions to resist impact damage should be provided in accordance with the design.

A screen should be provided to prevent birds and animals entering the cavity through the ventilation and drainage openings.

Brick slip cladding systems can be applied direct to masonry backing walls without a cavity being provided.

Where required by the design, dpcs/dpms should be installed correctly to provide a physical barrier to the passage of moisture. Dpc/dpm arrangements which rely solely on sealant should not be used.

To ensure moisture is directed to the outside, dpc/dpm arrangements should be correctly formed with suitable upstands and stop ends including at the junction between the brick slip cladding system and any other component or system.

Guidance on interfaces is provided in Appendix 6.9-A.

Appropriate tapes and sealants should be used in accordance with the design and the manufacturer's recommendations to ensure satisfactory performance.

### (b) insulation and condensation

Insulation should be installed in accordance with the design and the manufacturer's recommendations, ensuring that all parts of the backing wall are adequately insulated.

Insulation should be returned into window and door openings and be continuous around penetrations through the wall.

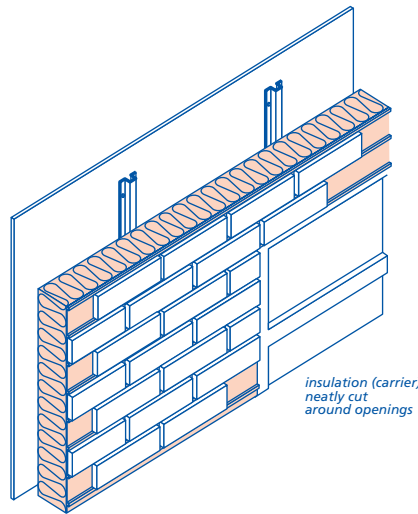

### (c) air infiltration

The backing wall should be reasonably airtight before installation of the brick slip cladding system, e.g.

- masonry walls jointed to a high standard with all joints etc filled
- framed walls with a rigid sheathing on the cavity face with all joints taped and sealed.

### (d) brick slips

Brick slips should be fixed in accordance with the design and manufacturer's recommendations, taking account of relevant height restrictions.

Excessive cutting of brick slips should be avoided.

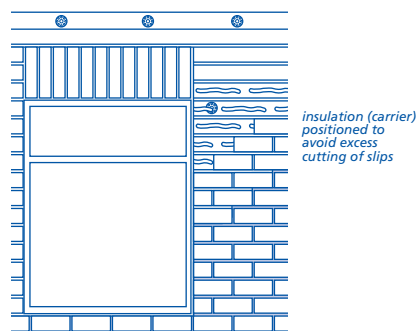

### (e) joints

Proprietary mortars and grouts should be used in accordance with the design and the manufacturer's recommendations. Each joint should be adequately filled and appropriately struck.

## TOLERANCES

### 6.9 - S20 Installation shall achieve satisfactory appearance

Installation should allow for the line, level, plumb and plane of the completed brick slip cladding system to be within reasonable tolerances for the materials involved. See Chapter 1.2 'A consistent approach to finishes'.

## APPENDIX 6.9-A

### Interfaces

Interfaces exist:

- between different curtain walling and cladding systems, and
- between curtain walling and cladding systems and other elements of the building.

All interfaces should be carefully designed and detailed to resist water and wind penetration. External and internal air and water seals should normally be provided.

The design should take account of:

- differing profile characteristics
- movement
- continuity of insulation, vapour barriers and breather membranes
- tolerances and deviation
- the erection sequence
- planned maintenance.

The drawings and specification should indicate clearly which contractor is responsible for constructing the interface.

### Typical interfaces

The following sketches show examples of typical interfaces and illustrate general design principles.

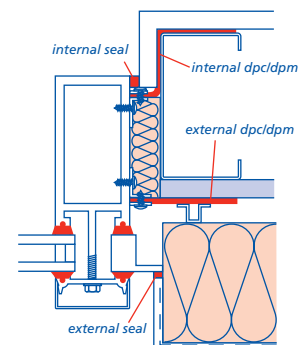

### 1. Curtain walling to insulated render system

Horizontal section

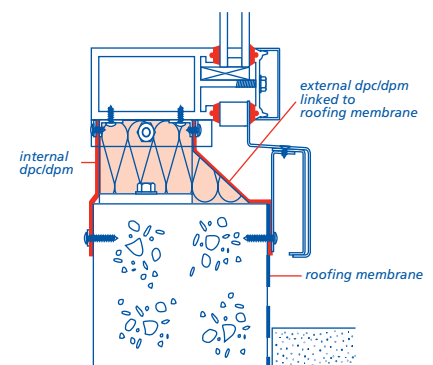

### 2. Curtain walling to balcony/terrace

Vertical section

# 6.9 Curtain walling and cladding

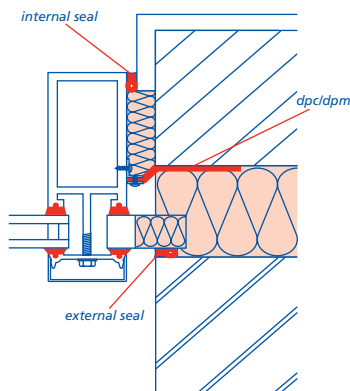

**3. Curtain walling to conventional brick & block wall**  
Horizontal section

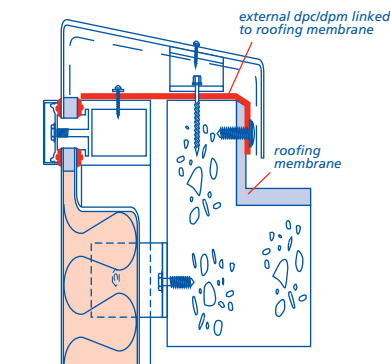

**5. Curtain walling to roof including coping detail**  
Vertical section

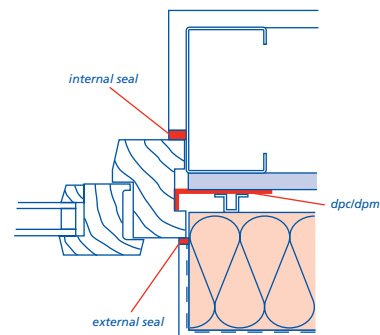

**7. Insulated render system to windows & doors**  
Horizontal section

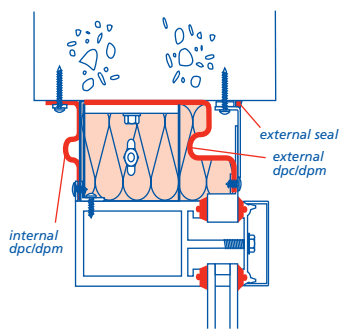

**4. Curtain walling to soffit**  
Vertical section

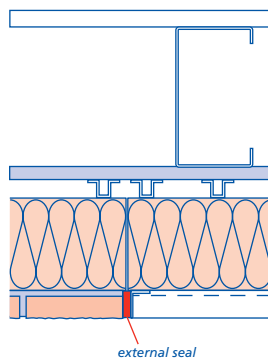

**6. Brick slip cladding to insulated render system**  
Horizontal section

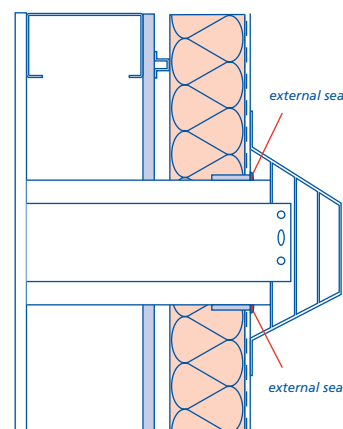

**8. Penetration of gas flue through insulated render system on light gauge steel frame**  
Horizontal section

## INDEX

<b>A</b>		<b>E</b>		<b>M</b>	
Accessibility for maintenance	2	Earth bonding	3, 5	Movement	2, 4, 5, 6, 9, 11
Acoustic performance	3, 5	Electrical continuity	3, 5	<b>P</b>	
Air infiltration	3, 4, 10, 12, 13	<b>F</b>		Primary components	2
<b>B</b>		Fire-stops	8	Provision of information	7
Backing wall	1, 4, 5, 6, 7	Fixings	2, 4, 5, 6, 8	<b>R</b>	
Brackets	2	<b>G</b>		Reinforcement	6, 12
Breather membranes	8	Gaskets	8, 9	Replaceable components	2
Brick slips	7, 13	<b>H</b>		<b>S</b>	
<b>C</b>		Handling and storage	9	Sealant	8, 9
Carriers	7	<b>I</b>		Secondary components	2
Cavity barriers	8	In-service performance	2, 4, 5, 6	<b>T</b>	
Certification	2, 3, 5, 6	Insulated glass units	3	Testing	3, 10, 11
Compartmentation	5, 11	Insulated render	1, 5, 11	Tolerances	3, 5, 6, 7, 9, 11, 12, 13
Condensation	3, 4, 6, 7, 9, 10	Insulation	4, 6, 7, 8, 10, 12, 13	<b>V</b>	
<b>D</b>		Interfaces	13	Ventilation screens	8
Design life	2	<b>J</b>		<b>W</b>	
Dpcs/dpms	8, 9	Joints	7, 13	Weather resistance	3, 4, 5, 6, 9, 10, 11, 12
Durability	3, 5, 6, 7, 11	<b>L</b>		Weathertightness	9, 10, 11, 12
		Loads	2, 4, 5, 6		

# Chapter 6.10

## Light steel framed walls and floors

---



# 6.10 Light steel framed walls and floors

## CONTENTS

	Clause	Page
<b>DESIGN</b>		
Design standards	D1	1
Statutory requirements	D2	1
Steel and fixings	D3	1
Loadbearing walls	D4	1
Non-loadbearing walls	D5	1
Moisture control and insulation	D6	2
Exterior cladding	D7	2
Floors	D8	2
Services	D9	4
Acoustic performance	D10	4
Control of fire	D11	4
Provision of information	D12-D13	4
Certification	D14	4

## MATERIALS

Material standards	M1	4
Steel and fixings	M2	4
Damp-proof courses	M3	5
Wallties and fixings	M4	5
Sheathing	M5	5
Breather membranes	M6	5
Thermal insulation	M7	5
Vapour control layers	M8	5
Plasterboard	M9	5
Cavity barriers and fire-stops	M10	5
Floor decking	M11	5

## SITWORK

Sitework standards	S1	6
Construction of loadbearing walls and external infillwalls	S2	6
Insulation	S3	7
Breather membranes	S4	7
Wallties and fixings	S5	7
Vapour control layers	S6	7
Cladding	S7	7
Construction of non-loadbearing internal walls	S8	8
Separating walls	S9	8
Light steel joists	S10-S15	8-10
Separating floors	S16	10
Services	S17	10
Control of fire	S18	10

## APPENDIX 6.10-A

Certification procedure		10
-------------------------	--	----

## INDEX

11

## SCOPE

This Chapter gives guidance on meeting the Technical Requirements and recommendations for light steel framed walls and floors.

## DESIGN STANDARDS

### 6.10 - D1 Design shall meet the Technical Requirements

Design that follows the guidance below will be acceptable for external and internal walls, and floors using light steel framing.

This Chapter only applies to light steel framing, typically 0.45 to 3.2mm thick, as described and illustrated. Construction should be 'warm frame' with sufficient insulation outside the steel envelope to ensure that condensation does not fall within the depth of the light steel members.

For dwellings that incorporate loadbearing light steel framed walls and/or floors, both system and project certification will be required in accordance with Appendix 6.10-A.

For the purpose of this Chapter, non-loadbearing walls are those not designed to carry the principal dead and imposed loads or provide the overall stability for the building. In some circumstances (e.g. external infill walls) they will carry wind loads.

If the light steel framing is of a novel construction, not shown in this Chapter, NHBC will require assessment in accordance with Technical Requirement R3.

This Chapter does not apply to light steel framed external walls used in basements.

## STATUTORY REQUIREMENTS

### 6.10 - D2 Design shall comply with all relevant statutory requirements

Design should be in accordance with relevant Building Regulations and other statutory requirements.

## STEEL AND FIXINGS

### 6.10 - D3 Steel and fixings shall be suitable for the design and adequately protected against corrosion

Items to be taken into account include:

#### (a) steel

Steel should be grade S280 or S350 to BS EN 10326. Grade S390 steel may be used if it has a nominal yield strength of 390N/mm<sup>2</sup> and meets with the concepts of BS EN 10326.

To provide adequate protection against corrosion due to condensation and the environment, steel should be pre-galvanised in accordance with BS EN 10326 to provide a minimum zinc coating of 275 g/m<sup>2</sup>.

#### (b) compatibility

Where two metals are to be joined they should be compatible and not cause bimetallic corrosion in that environment. Alternatively they should be isolated from each other.

The choice of fixings should take account of bimetallic corrosion which can occur when two dissimilar metals are in contact.

#### (c) connections

Light steel components should be securely fixed together by bolting, welding, riveting, clinching, crimping, screwing or nailing.

Connections using these techniques should be justified either by design to BS EN 1993-1-3 or an appropriate test acceptable to NHBC.

## LOADBEARING WALLS

### 6.10 - D4 Loadbearing walls incorporating light steel members shall be designed to support and transfer loads to foundations safely and without undue movement

Items to take into account include:

#### (a) design

The structural design of loadbearing steel framed walls should be in accordance with BS EN 1993-1-3.

#### (b) design loadings

The building should be designed to resist loadings in accordance with BS EN 1991-1-1, BS EN 1991-1-3 and BS EN 1991-1-4 including:

- dead loads
- imposed loads
- wind loads.
- snow loads

#### (c) structural elements

Individual studs should not be less than 36mm wide, spaced at not more than 600mm centres, unless agreed with NHBC and other support is provided for wall boards and fixings.

A lintel should be provided to any opening in loadbearing panels where one or more studs is cut or displaced to form the opening. A lintel is not required where an opening falls between studs.

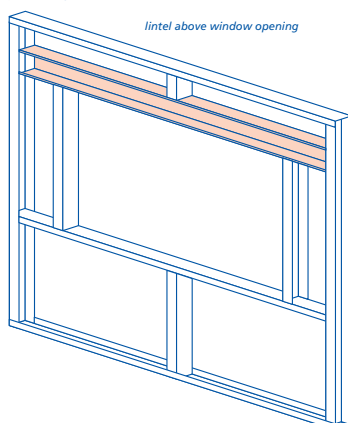

Additional studs may be required at openings for fixing ties or supports for the cladding.

Multiple studs should be included to support multiple joists unless otherwise specified by the designer.

Lintels should be securely fixed to supporting studs to ensure that loads are transferred properly.

Where panels are diagonally braced with flat strip it should be fixed to each stud at the intersection to minimise the bow in the bracing member.

#### (d) joints between panels and other elements

The design should detail how wall panels are to be securely fixed:

- to the substructure
- to adjacent panels
- to the floor and roof framing.

Account should be taken of uplift forces and, where necessary, proper holding down devices should be provided to resist uplift. The anchorage for holding down devices should have sufficient mass to resist the uplift forces.

Timber wall plates should be fixed to the head rail of wall panels onto which timber roof trusses bear. The timber wall plate and head rail should be sized to permit single timber trusses to be positioned at any point between studs.

#### (e) racking

Wall panels may provide resistance to racking forces using one or more of the following techniques:

- internal bracing
- crossed flat bracing
- internal sheathing board
- external lining board
- rigid frame action.

Methods adopted should be justified either by design to BS EN 1993-1-1 or tested to BS EN 594.

## NON-LOADBEARING WALLS

### 6.10 - D5 Non-loadbearing walls incorporating light steel members shall have adequate strength and support

Items to take into account include:

#### (a) construction

The following form of construction is acceptable:

- light steel partitions using studs, head and base rails from sections not smaller than 43mm x 32mm x 0.45mm
- stud spacings to suit the thickness of plasterboard, as follows:
  - not more than 450mm spacing for 9.5mm boards
  - not more than 600mm spacing for 12.5mm or thicker boards.



# 6.10 Light steel framed walls and floors

## (b) movement joints

Non-loadbearing walls should not bridge movement joints in the main structure.

A joint should be constructed between the frame and any chimney or flue to prevent load transfer onto the chimney or flue.

## (c) support

Non-loadbearing walls should be supported from the structural floor, not by a floating floor that incorporates a compressible layer, unless the floating floor is specifically designed for that purpose.

Allowance should be made for the possible deflection of floors at the head of non-loadbearing walls to prevent the wall becoming loadbearing.

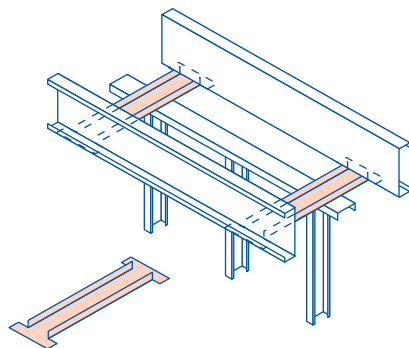

SUPPORT WHERE WALL IS PARALLEL AND BETWEEN JOISTS

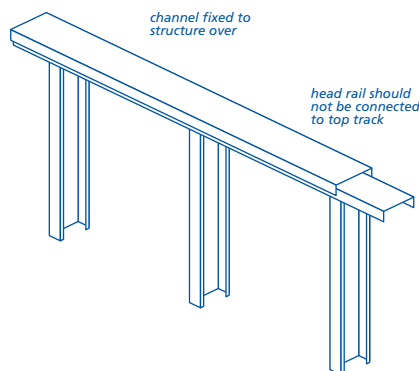

SUPPORT WHERE FLOOR OR BEAM IS ABOVE WALL

## MOISTURE CONTROL AND INSULATION

**6.10 - D6 Wall designs shall ensure that the structure is adequately protected from the effects of moisture**

Items to be taken into account include:

### (a) provision of dpcs and dpms

Dpcs should be installed beneath and for the full width of the lowest section of framing (e.g. all ground floor walls and internal partitions) to protect the steel from corrosion due to moisture. The dpc should be wide enough to lap with the dpm.

Dpcs and trays should be provided at openings to prevent rain penetration.

## (b) membranes

Breather membranes and other barriers, where provided, should be lapped so that each joint is protected and moisture drains outwards.

## (c) cavities in external walls

A clear cavity should be provided to reduce the risk of rain penetrating to the frame. The following minimum cavity widths, measured between the claddings and sheathings, should be provided:

Cladding	Cavity width
Masonry	50mm nominal
Render on backed lathing	25mm nominal
Vertical tile hanging without underlay	No vertical cavity required when a breather membrane is provided
Other cladding*	15mm nominal

\* see Chapter 6.9 'Curtain walling and cladding'

The cavity should extend at least 150mm below the dpc and be kept clear to allow drainage. Weep holes or other suitable means of drainage should be provided where necessary to prevent water build up in the cavity.

## (d) insulation and interstitial condensation

The BRE Report 'Thermal insulation: avoiding risks' discusses aspects of insulation relevant to external light steel framed walls. In England and Wales account should be taken of Accredited Details for Part L.

A vapour control layer should be provided unless a condensation risk analysis in accordance with BS 5250 shows that one is not necessary. The vapour control layer should be fixed on the warm side of the wall insulation.

The vapour control layer should cover the external wall including base rails, head rails, studs, lintels and window reveals.

Vapour control layers should be of 500g polyethylene or vapour control plasterboard.

Insulation should continue 150mm below the base rail of the steel wall to minimise thermal bridging.

Insulation with an integral facing on one side only, e.g. a foil facing, should have the facing on the cavity side. The facing should not be used as the vapour control layer.

Service pipes, conduits, etc within walls should be on the warm side of the insulation.

## EXTERIOR CLADDING

**6.10 - D7 Exterior cladding shall be compatible with the steel frame**

Items to be taken into account include:

### (a) wall ties

Wall ties for masonry claddings should be:

- of a type which accommodates differential movement between the light steel frame and the cladding - see clause D7(c) below
- fixed through to the studs, not the sheathing
- installed at a minimum density of 3.7 ties/m<sup>2</sup> e.g. spaced at a maximum of 600mm horizontally and 450mm vertically (see Sitework clause 6.10 - S5)
- spaced at jambs of openings a maximum of 300mm vertically within 225mm of the masonry reveal. Additional studs may be needed to achieve this
- inclined away from the light steel framing.

### (b) masonry claddings

Soft joints should be provided to allow for differential movement. A gap of 1mm per metre of masonry should be provided at openings and soffits.

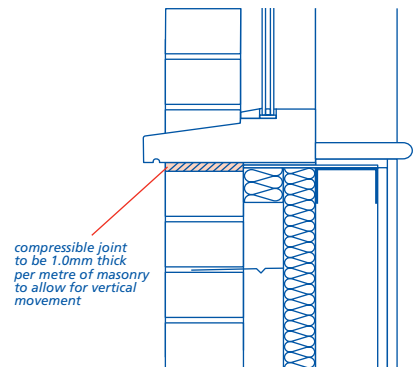

### (c) other claddings

For other claddings reference should be made to Chapter 6.9 'Curtain walling and cladding' (Design and Sitework).

## FLOORS

**6.10 - D8 Suspended floors shall be designed to support and transmit loads safely to the supporting structure without undue deflection**

Items to be taken into account include:

### (a) dead and imposed loads

Floors should be designed to resist loading in accordance with BS EN 1991-1-1 including:

- dead loads
- imposed loads.

Information concerning balcony loading is given in Chapter 7.1 'Flat roofs and balconies' (Design and Sitework).

### (b) joist spacing

Steel joists should be spaced at centres not greater than 600mm.



**(c) deflection**

The in-service performance of light steel joists should be controlled by four serviceability criteria:

Static criteria:

- i) the maximum deflection for a single joist due to imposed load should be limited to span/450
- ii) the maximum deflection for a single joist due to dead and imposed loads should be limited to the lesser of span/350 or 15mm.

Dynamic criteria:

- iii) the natural frequency of the floor should be limited to 8Hz for dead load plus 0.2 x imposed load. This can be achieved by limiting the deflection of a single joist to 5mm for the given loading
- iv) the deflection of the floor (i.e. a series of joists plus the floor decking) when subject to a 1kN point load should be limited to the following values:

Span (m)	Max. deflection (mm)
3.5	1.7
3.8	1.6
4.2	1.5
4.6	1.4
5.3	1.3
6.2	1.2

The deflection of a single joist is dependent on the overall floor construction and the number of effective joists that are deemed to share the applied 1kN point load. The following table gives typical values:

Floor configuration	Number of effective joists	
	Joist centres	
	400mm	600mm
Chipboard, plywood or oriented strand board	2.5	2.35
Built-up acoustic floor	4	3.5

**(d) attachment to supporting structure**

Light steel joists should be fixed to supporting walls by web cleats, direct attachment to wall studs, or by bearing onto the supporting structure. In the latter configuration, bearing stiffeners may be required.

**(e) prevention of roll**

Floors constructed using joists with an asymmetric web (e.g. of 'C' or Sigma profile) can cause the floor to 'roll'. To avoid this, one of the following alternatives should be used where the span exceeds 3.5m for 'C' joists or 4.2m for Sigma joists:

- a continuous line (or lines) of proprietary steel herringbone struts provided between the joists. The pairs of struts should have a physical gap between them so that they do not rub against

each other at the cross-over point and create noise

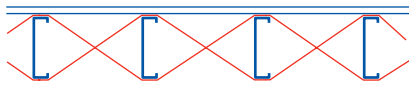

- solid blocking provided to every third pair of joists with ties between them



- joists alternately reversed and tied together in pairs

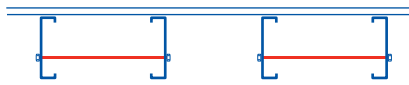

- joists alternately reversed and continuous ties (e.g. resilient bar) fixed to the joist flanges.

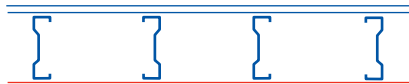

**(f) floor decking**

The correct thickness of decking should be specified for the joist centres used.

The thickness should be not less than those shown in this table for normal domestic loads, i.e. an imposed load of 1.5kN/m<sup>2</sup>.

Floor decking	Thickness of decking [mm]	
	Joist centres	
	400mm	600mm
Chipboard	18	22
Plywood	15	18/19
Oriented strand board	15	18/19

**Note**

Oriented strand board should be laid with the stronger axis at right angles to the supports. Other decking materials not listed in the table should comply with Technical Requirement R3. The above thicknesses may not be adequate to achieve a mass for floor decking of 15 kg/m<sup>2</sup> for sound insulation requirements of floors in England & Wales.

The floor deck is generally used as a diaphragm and, to achieve this, floor boarding should be attached using self-drilling, self-tapping screws, ring shank nails or other approved fixings at 300mm maximum centres. T&g joints should be glued.

**(g) openings**

Suitably sized trimmers should be provided around floor openings.

**(h) notching and holing**

The flanges of light steel joists should not be notched except to accommodate connections.

Drilling or punching through the web should only be carried out within recognised limits (see Sitework clause 6.10-S11).

**(i) ground floors**

Light steel joists used in ground floor construction should have thermal insulation positioned to ensure that condensation does not form on the joists.

The junction between the ground floor joists and their support should be designed to maintain the durability of the floor. Light steel floor joists and ring beams in ground floors should be galvanised to 450g/m<sup>2</sup>. Alternatively they can be galvanised to 275g/m<sup>2</sup> with additional protection of a two-coat bitumen based coating to BS 1070, BS 3416 or BS 6949, or have a two coat liquid asphaltic composition applied. Ring beams to ground floors should be totally protected and joists protected for 300mm adjacent to an external wall support or ring beam.

**(j) resistance to ground moisture**

Provision should be made to prevent ground moisture affecting light steel floors.

This can be achieved by either:

- 50mm concrete or 50mm fine aggregate on a polyethylene membrane laid on 50mm sand blinding, or
- 100mm concrete.

Where necessary, oversite concrete should be protected against sulfate attack by the use of a polyethylene sheet dpm, not less than 1200 gauge (0.3mm) (or 1000 gauge if assessed in accordance with Technical Requirement R3), properly lapped.

**(k) ventilation of underfloor voids**

A minimum ventilation void of 150mm should be provided below the floor.

On shrinkable soils where heave could take place, an allowance for movement should be added to the underfloor ventilation requirement to determine the minimum dimension of the floor void. The allowance for movement relates to the shrinkage potential of the soil as follows:

- high potential - 150mm
- medium potential - 100mm
- low potential - 50mm.

Void should be ventilated by openings providing not less than either 1500mm<sup>2</sup> per metre run of external wall or 500mm<sup>2</sup> per m<sup>2</sup> of floor area, whichever gives the greater opening area.

# 6.10

## Light steel framed walls and floors

Every part of the void under the floor should be thoroughly ventilated through openings on at least two opposite sides.

### SERVICES

#### 6.10 - D9 Services shall be adequately protected from damage

Cutting of service holes on site should be avoided since badly cut edges can have an adverse affect on the durability of the frame and may cause damage to pipes and cables.

Grommets should be used around the edge of service holes to protect electrical cables and reduce the risk of bimetallic corrosion. Swagged holes for electric cables and plastic piping do not require grommets.

Service mains and service outlets should be designed to ensure the fire resistance of walls and floors is not impaired.

In Scotland, services are not permitted within framed separating walls.

### ACOUSTIC PERFORMANCE

#### 6.10 - D10 Internal walls and floors shall be designed to adequately resist the passage of sound

Designs should be in accordance with relevant Building Regulations and other statutory requirements.

### CONTROL OF FIRE

#### 6.10 - D11 Walls and floors shall resist the spread of fire

All structural elements should have adequate fire resistance.

Items to be taken into account include:

##### (a) ceilings

Ceilings should provide the necessary fire protection to floors constructed with light steel joists. Either one or two layers of plasterboard are required and at least one of these should be fire-rated. When two layers of board are used, joints should be staggered between layers. Boards should be attached using self-drilling, self-tapping screws.

##### (b) cavity barriers

Cavity barriers should be provided in accordance with relevant Building Regulations.

Horizontal cavity barriers (except under eaves) should be protected with a dpc tray. The tray should have a minimum upstand of 100mm. Alternatively polyethylene encased cavity barriers providing a minimum upstand of 100mm should be used.

##### (c) fire-stops

Fire-stops should be provided in accordance with relevant Building Regulations.

### PROVISION OF INFORMATION

#### 6.10 - D12 Designs and specifications shall be produced in a clearly understandable format and include all relevant information

For light steel framed walls and floors, the following information should be available:

- relevant drawings
- materials specification
- fixing schedules
- fixing details
- manufacturers' recommendations relating to proprietary items.

The information should be in a form suitable for the use of site operatives and be available on site before and during construction.

Assembly instructions should allow for every structural connection made on site including fixing details for framing, wall ties and should show as appropriate:

- number and spacing of bolts, screws and rivets
- size and type of each fixing type, including corrosion protection.

#### 6.10 - D13 All relevant information shall be distributed to appropriate personnel

Ensure that design and specification information is issued to site supervisors and relevant specialist subcontractors and/or suppliers.

Where proprietary products are to be used, manufacturers usually have specific requirements for fixing and/or assembly of their products. This information should also be made available for reference on site so that work can be carried out satisfactorily in accordance with the design and specification.

Copies of the assembly instructions should be given to the person doing the job.

### CERTIFICATION

#### 6.10 - D14 Design of the superstructure shall be checked by an NHBC steel frame certifier

The specific project details should be checked by an NHBC steel frame certifier so that a certificate can be issued in accordance with Appendix 6.10-A. The project certificate should be made available on site for inspection by NHBC.

### MATERIALS STANDARDS

#### 6.10 - M1 All materials shall:

- (a) meet the Technical Requirements
- (b) take account of the design

Materials that comply with the design and the guidance below will be acceptable for external and internal walls, and floors using light steel framing.

Materials for external and internal walls and floors using light steel framing should comply with all relevant standards, including those listed below. Where no standard exists, Technical Requirement R3 applies (see Chapter 1.1 'Introduction to the Standards and Technical Requirements').

References to British Standards and Codes of Practice include those made under the Construction Products Directive (89/106/EEC) and, in particular, appropriate European Technical Specifications approved by a European Committee for Standardisation (CEN).

### STEEL AND FIXINGS

#### 6.10 - M2 Steel and fixings shall be suitable for the design and adequately protected against corrosion

Items to be taken into account include:

##### (a) steel

Steel should be grade S280 or S350 to BS EN 10326. Grade S390 steel may be used if it has a nominal yield strength of 390N/mm<sup>2</sup> and meets the concepts of BS EN 10326.

To provide adequate protection against corrosion due to condensation and the environment, the steel should be pre-galvanised in accordance with BS EN 10326 to provide a minimum zinc coating of 275g/m<sup>2</sup>.

Light steel floor joists and ring beams in ground floors should be galvanised to 450g/m<sup>2</sup>. Alternatively they can be galvanised to 275g/m<sup>2</sup> with additional protection of a two-coat bitumen based coating to BS 1070, BS 3416 or BS 6949, or have a two coat liquid asphaltic composition applied. Ring beams to ground floors should be totally protected and joists protected for 300mm adjacent to the support or ring beam.

##### (b) compatibility

Where two metals are to be joined they should be compatible and not cause bimetallic corrosion in that environment. Alternatively the two metals should be isolated from each other.

The choice of fixings needs to take account of bimetallic corrosion which can occur when two dissimilar metals are in contact.

**(c) connectors**

The following connectors are acceptable:

- zinc plated bolts should be in accordance with BS 4190
- countersunk bolts should be in accordance with BS 4933
- screws should be in accordance with BS 5427
- rivets should be in accordance with the manufacturer's recommendations
- self-piercing rivets should be in accordance with the manufacturer's recommendations
- ring shank nails should be in accordance with BS EN 10263
- welded connections should be in accordance with BS 5135. The welding wire should be in accordance with BS 2901.

Cleats should comply with the requirements of BS EN 1993-1-1.

**(d) holding down devices**

Holding down devices should be manufactured from mild steel with zinc coating to BS 729 or BS 1706 and be suitable for the environment they will be exposed to.

Holding down devices manufactured from stainless steel to BS EN 10095 will be suitable in any environment.

**DAMP-PROOF COURSES**

**6.10 - M3 Materials for damp-proofing shall adequately resist the passage of moisture**

Materials which are acceptable for use as dpcs include:

- polyethylene to BS 6515
- bitumen to BS 6398
- proprietary materials assessed in accordance with Technical Requirement R3.

**WALL TIES AND FIXINGS**

**6.10 - M4 Wall ties and fixings shall connect the steel frame to the cladding in accordance with the design**

For masonry claddings wall ties should be of austenitic stainless steel, phosphor bronze or silicon bronze. Materials for wall ties should be compatible. Stainless steel, phosphor bronze and silicon bronze are compatible with each other.

For other claddings, ties and fixings should be assessed in accordance with Technical Requirement R3.

**SHEATHING**

**6.10 - M5 Sheathing shall be durable and capable of providing structural resistance to racking**

Cement bonded particle board sheathing should be in accordance with BS EN 634 and BS EN 13986.

Plywood sheathing should be:

- of performance characteristics determined in accordance with BS EN 13986 table 7
- suitable for in humid conditions to BS EN 636
- at least 5.5mm thick
- appropriate to the exposure of the building.

Oriented strand board should be OSB3 to BS EN 300 and be at least 8mm thick.

Proprietary sheathing materials should be assessed in accordance with Technical Requirement R3 and used in accordance with the assessment.

**BREATHER MEMBRANES**

**6.10 - M6 Breather membranes shall be capable of allowing water vapour from within the frame to pass out into the cavity and protect the sheathing and frame from external moisture**

Breather membranes should be:

- vapour resistant to less than 0.6MNs/g when calculated from the results of tests carried out in accordance with BS 3177 at 25°C and relative humidity of 75%
- capable of resisting water penetration
- self-extinguishing
- durable
- adequately strong when wet to resist site damage
- Type 1 to BS 4016 in areas of Very Severe exposure.

**THERMAL INSULATION**

**6.10 - M7 Insulation materials shall be of a suitable thickness to comply with the design and statutory requirements**

Insulation materials should be inert, durable, rot and vermin proof and should not be adversely affected by moisture or vapour.

The following materials are acceptable:

- mineral wool to BS EN 13162
- FR (flame retardant) grade expanded polystyrene to BS EN 13163
- FR (flame retardant) grade extruded polystyrene to BS EN 13164
- rigid polyurethane foam and polyisocyanurate to BS EN 13165
- phenolic foam to BS EN 13166
- cellular glass to BS EN 13167.

Other insulation materials should be assessed in accordance with Technical Requirement R3.

**VAPOUR CONTROL LAYERS**

**6.10 - M8 Vapour control layers shall restrict the passage of water vapour from within the dwelling to the steel frame**

Minimum 500 gauge polyethylene sheet or vapour control plasterboard should be used.

Vapour control products manufactured from recycled materials should be assessed in accordance with Technical Requirement R3.

**PLASTERBOARD**

**6.10 - M9 Plasterboard shall be of a suitable thickness for its intended use**

Plasterboard should be to BS 1230. Plasterboard thickness should be not less than:

- 9.5mm for stud spacings up to 450mm
- 12.5mm for stud spacing up to 600mm.

To provide fire-resistance, fire-rated boards should be used and installed in accordance with the manufacturer's instructions.

**CAVITY BARRIERS AND FIRE-STOPS**

**6.10 - M10 Materials used for cavity barriers and fire-stops shall be capable of providing adequate resistance to fire and smoke**

Materials specified in statutory requirements are acceptable.

Suitable fire-stopping materials include:

- mineral wool
- glass wool
- cement mortar
- gypsum plaster
- intumescent mastic or preformed strip
- proprietary sealing systems (particularly those designed for service penetrations) assessed in accordance with Technical Requirement R3 to maintain the fire resistance of the wall.

**FLOOR DECKING**

**6.10 - M11 The type and thickness of the decking material shall have adequate strength and moisture resistance**

The following materials are acceptable:

- moisture-resistant chipboard Type P5 to BS EN 312
- oriented strand board Type OSB3 to BS EN 300
- plywood in accordance with BS EN 636.

Fixings and supports should be as recommended by the manufacturer.

Floor decking materials not covered by a British Standard should be assessed in accordance with Technical Requirement R3.

# 6.10 Light steel framed walls and floors

## SITWORK STANDARDS

### 6.10 - S1 All sitework shall:

- (a) meet the Technical Requirements
- (b) take account of the design
- (c) follow established good practice and workmanship

Sitework that complies with the design and the guidance below will be acceptable for external and internal walls, and floors using light steel framing.

Information in a form suitable for the use of site operatives should be available on site before and during construction including:

- relevant drawings
- materials specification
- fixing schedules
- fixing details
- manufacturers' recommendations relating to proprietary items.

## CONSTRUCTION OF LOADBEARING WALLS AND EXTERNAL INFILL WALLS

### 6.10 - S2 Construction of loadbearing walls and external infill walls shall ensure adequate stability

Items to be taken into account include:

#### (a) setting out

The structure onto which the light steel frame is to be erected should be correctly set out in accordance with the design. The loads from the light steel frame should be supported as detailed in the design.

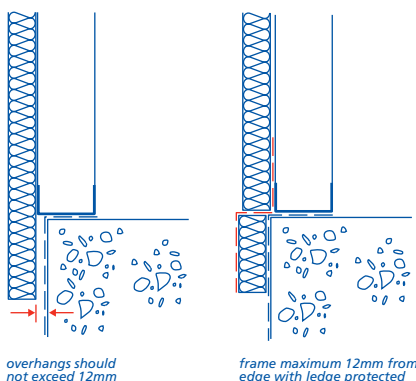

The supporting structure may have local deviations in level along its length and some packing will be required to achieve the required tolerances and to provide for effective load transfer.

The following guidance should be used, unless the frame manufacturer confirms otherwise:

Gap under base rail	Acceptable packing
less than 10mm	provide shims under each stud position
10 - 20mm	provide shims under each stud position and grout under the whole length of the base rail with cement:sand mortar
more than 20mm	obtain advice from the frame designer/manufacturer - remedial work to the substructure may be required before erection commences

Shims should be of pre-galvanised steel. Plastic or timber shims are not acceptable.

#### (b) accuracy of walls

Wall frames should be checked to ensure that they are dimensionally accurate before erection commences.

All light steel framing should be correctly positioned, square and plumb. The verticality of a light steel frame, relative to its base should be +/- 5mm per storey.

The horizontal position of the base rail should not vary in alignment by more than 5mm in 10m.

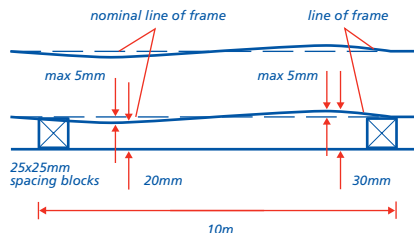

#### (c) anchoring the frame

The frame should be anchored to resist both lateral movement and uplift as required by the design.

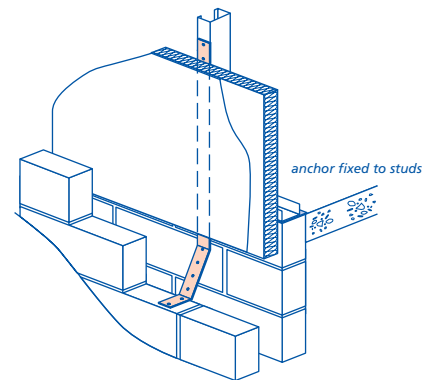
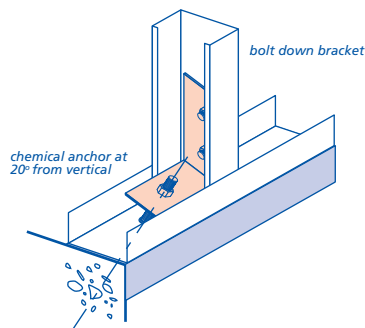

Shot-fired fixings should observe a minimum edge dimension to prevent spalling at edges of masonry or slabs. When shotfiring into masonry, solid concrete blocks with a minimum crushing strength of 7.3 N/mm<sup>2</sup> should be used, positioned to receive fixings.

Where the design incorporates gas membranes (methane or radon) fixings should not puncture them but where this is unavoidable the penetration should be sealed.

#### (d) alterations

Steelwork should only be altered with the approval of the designer. Welded or flame cut edges should be cleaned before being treated with a zinc-rich paint to prevent corrosion.

#### (e) fixing panels

Wall panels should be securely fixed together and to floors in accordance with the design.

#### (f) masonry claddings

Soft joints should be provided to allow for differential movement. A gap of 1mm per metre of wall height should be provided at openings and soffits.

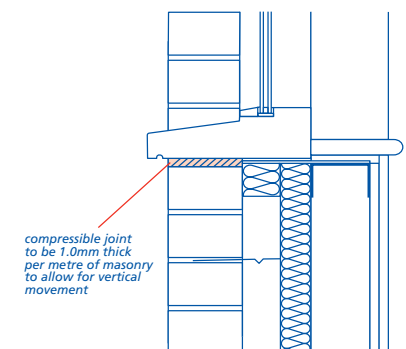

#### (g) supporting claddings

Masonry claddings should not be supported by the light steel framed walls unless shown in the design.

Masonry claddings may be tied to the light steel framed walls with flexible wall ties fixed through to the studs.

Lightweight claddings should be supported by the light steel framed walls on battens or by other suitable means unless shown otherwise in the design.



**(h) fixing wallboard**

Plasterboard should be fixed in accordance with Chapter 8.2 'Wall and ceiling finishes' (Sitework).

Other wallboards should be fixed in accordance with the manufacturer's recommendations.

Wallboards should be attached to light steel studs using self-drilling, self-tapping screws at not more than 300mm centres.

Other fixings should be in accordance with the manufacturer's recommendations.

Particular care should be taken at the junction between walls and roofs. Reference should be made to Chapter 8.2 'Wall and ceiling finishes' (Sitework).

**(i) movement between steel frame wall and other elements**

Movement joints between light steel framed walls and other elements should be provided in accordance with the design.

A joint should be constructed between the frame and any chimney or flue to prevent load transfer onto the chimney or flue.

**(j) cavities**

A clear cavity should be provided to reduce the risk of rain penetrating to the frame. The following minimum cavity widths, measured between the claddings and sheathings, should be provided.

Cladding	Cavity width
Masonry	50mm nominal
Render on backed lathing	25mm nominal
Vertical tile hanging without underlay	No vertical cavity required when a breather membrane is provided
Other cladding*	15mm nominal

\* see Chapter 6.9 'Curtain walling and cladding'

The cavity should be extended at least 150mm below the dpc and be kept clear to allow drainage. Weep holes or other suitable means of drainage should be provided where necessary to prevent water build up in the cavity.

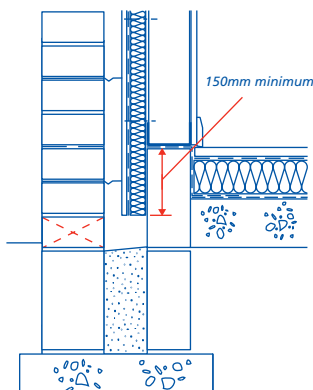

**INSULATION**

**6.10 - S3 Insulation shall be correctly installed**

Insulation should cover the whole external face of the wall and extend 150mm below the bottom rail to maintain a warm frame.

Insulation boards should be tightly butted. Joints between boards should be taped with a suitable tape where required by the design.

Foil-faced insulation boards with an integral facing on one side only should be fixed with the foil face on the cavity side.

**BREATHER MEMBRANES**

**6.10 - S4 Breather membranes shall be provided where required by the design**

Breather membranes should be lapped so that each joint is protected and moisture drains outwards.

Laps should be at least 100mm on horizontal joints and 150mm on vertical joints.

**WALL TIES AND FIXINGS**

**6.10 - S5 Wall ties and fixings shall be correctly installed**

Wall ties should:

- be fixed through to the studs
- be inclined away from the light steel framing
- be kept clean and free from mortar droppings.

Wall ties should be spaced as required by the design but not less than 3.7 ties/m<sup>2</sup> e.g. spaced at a maximum of 600mm horizontally and 450mm vertically. At jambs of openings the spacing should be a maximum of 300mm vertically with ties set within 225mm of the masonry reveal.

Other fixings should be of the type specified, and be fixed in accordance with the design.

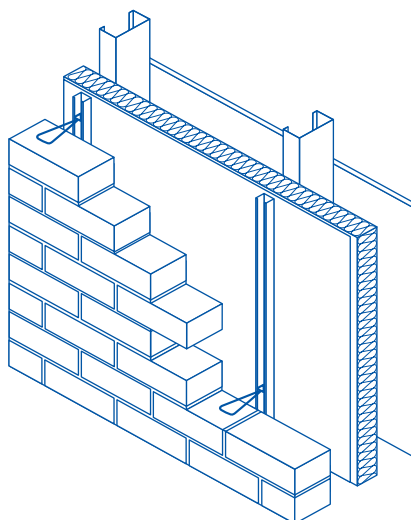

**VAPOUR CONTROL LAYERS**

**6.10 - S6 A vapour control layer shall be correctly installed in accordance with the design**

Where required by the design a vapour control layer should be fixed on the warm side of the insulation and frame.

The vapour control layer should be of the material specified in the design. Minimum 500 gauge polyethylene sheet or vapour control plasterboard should be used.

Where polyethylene sheet is used all joints in the vapour control layer should have at least 100mm laps, located on studs or noggings. Double sided tape or adhesive should be used as a temporary fixing before the wall board is fixed.

Where vapour control plasterboard is used, joints between sheets should be positioned on studs or noggings. When cutting vapour control plasterboard, care should be taken not to displace the vapour control material.

Any holes made in the vapour control layer should be made good and sealed.

The vapour control layer should cover the external wall including base rails, head rails, studs, lintels and window reveals.

At the base of the wall the vapour control layer should overlap the base rail.

**CLADDING**

**6.10 - S7 Cladding shall be correctly installed**

Masonry cladding should be constructed in accordance with Chapter 6.1 'External masonry walls' (Design and Sitework).

For other claddings reference should be made to Chapter 6.9 'Curtain walling and cladding' (Design and Sitework).

A clear cavity should be provided between the sheathing and the cladding. The cavity should be drained. Where wall areas are divided by cavity barriers, the drainage of the cavity should be maintained or cavity trays and weep holes installed.

Drainage at the base of the cladding system should be equivalent to 500mm<sup>2</sup>/m run (e.g. for masonry, one open perpendicular every 1.5m).

Openings for drainage should be placed to prevent the ingress of rain.

The cavity should be kept clean, free of obstructions and should be capable of draining freely.

# 6.10 Light steel framed walls and floors

## CONSTRUCTION OF NON-LOADBEARING INTERNAL WALLS

**6.10 - S8 Construction of non-loadbearing internal walls shall ensure adequate stability**

Items to be taken into account include:

**(a) setting out and workmanship**

Partitioning should be correctly positioned, square and plumb.

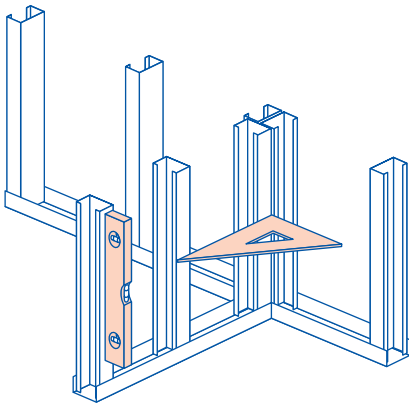

Studs should be spaced at maximum 450mm or 600mm centres to suit the wall board thickness as required by the design. Extra studs should be provided at openings, if required by the design.

**(b) size of steel members**

Non-loadbearing partitions should be constructed in accordance with the design.

**(c) alterations**

Steelwork should only be altered with the approval of the designer. Welded or flame cut edges should be cleaned and treated with a zinc-rich paint to prevent corrosion.

**(d) support and fixings**

Non-loadbearing partitions should be fixed in accordance with the design. They should be fixed to the floor on which they stand, at the head, to each other and to abutting walls. Noggings or extra studs should be used where shown in the design.

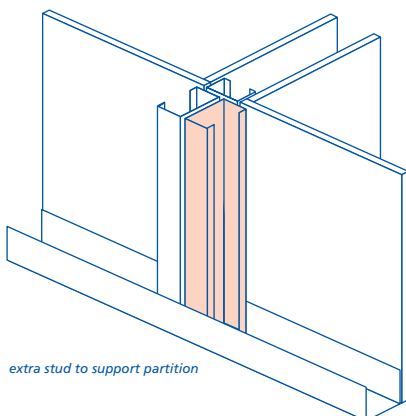

extra stud to support partition

Non-loadbearing partitions should not be wedged against floor joists, ceiling joists or roof trusses. Allowance should be made for the floor joists, ceiling joists or roof trusses to deflect so that the partition does not become loadbearing.

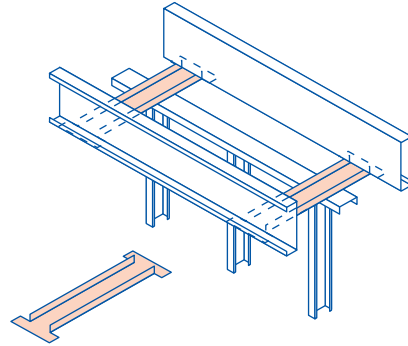

SUPPORT WHERE WALL IS PARALLEL AND BETWEEN JOISTS

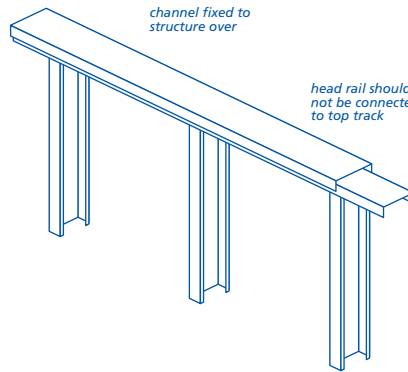

channel fixed to structure over

head rail should not be connected to top track

SUPPORT WHERE FLOOR OR BEAM IS ABOVE WALL

Noggings or straps should be provided as required to support fittings, such as radiators, wall-mounted boilers, sanitary fittings, kitchen units, etc.

Fixing and finishing of partitions should be in accordance with Chapter 8.2 'Wall and ceiling finishes' (Sitework).

## SEPARATING WALLS

**6.10 - S9 Construction of separating walls shall ensure adequate sound insulation**

The design details should be carefully followed.

There should be no gaps in the:

- mineral wool quilt or batts
- wallboard layers
- fire-stopping.

Services in or adjacent to separating walls should be installed in accordance with the design. (See clause 6.10 - S17).

## LIGHT STEEL JOISTS

**6.10 - S10 Light steel joists shall be selected, located and supported as detailed in the design**

Items to be taken into account include:

**(a) protection**

Where required by the design ground floor joists should be protected by the application of a two-coat bitumen based coating, or have a two-coat liquid asphaltic composition applied. Ring beams to ground floors should be totally protected and joists protected for 300mm adjacent to the support or ring beam.

**(b) joist spacings**

Joist spacings should be as shown in the design.

**(c) joist support cleats**

Joist support cleats should be of the correct type and fitted in the specified location with the fixings specified in the design.

Where joists are fitted directly to light steel wall studs, pre-drilled holes should be correctly aligned before making the final connection.

Fixing holes should not be enlarged and additional holes should not be cut without the consent of the designer.

Where required, web stiffeners should be properly fitted to ensure good bearing.

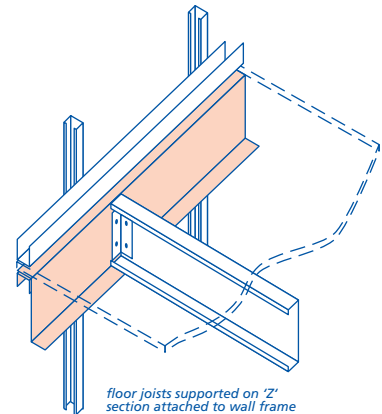

floor joists supported on 'Z' section attached to wall frame

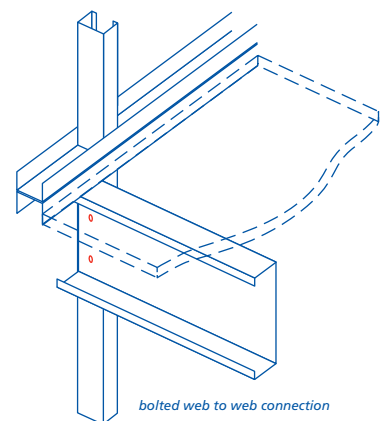

bolted web to web connection

**(d) joist length and end support**

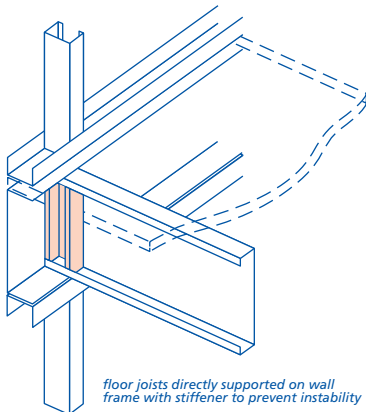

Joists should be accurately cut to length in the factory to ensure a tight fit. The correct type, size and number of fixings should be as specified at every connection.

**(e) support of trimmed and trimming joists**

Some end notching of light steel joists may be required for interconnection of trimming joists. This should be in accordance with the design. Notches elsewhere in the span are unacceptable. Welded or flame cut edges should be cleaned and treated with zinc-rich paint to prevent corrosion.

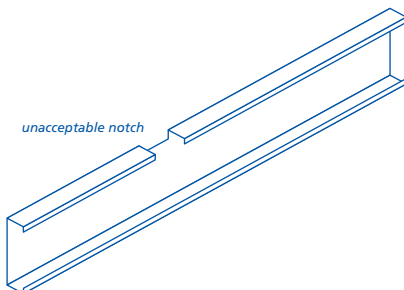

**(f) joist bearings**

Where light steel joists are supported by steel joists, cleats or web stiffeners should be used in accordance with the design.

**(g) fixing of multiple joists**

Joists may be doubled up to support partitions or to form trimmers. Fixings should be in accordance with the design and should be properly installed. Bolted connections should be tightened to the torque given in the design.

**(h) prevention of roll**

Bridging and blocking should be provided in accordance with the design to prevent roll.

Floors constructed with joists with an asymmetric web (e.g. of 'C' or Sigma profile) can cause the floor to 'roll'.

To avoid this one of the following alternatives should be provided where the

span exceeds 3.5m for 'C' joists or 4.2m for Sigma joists unless otherwise specified in the design:

- a continuous line (or lines) of proprietary steel herringbone strutting provided between the joists. The pairs of ties should have a physical gap between them so that they do not rub against each other at the cross-over point and cause noise

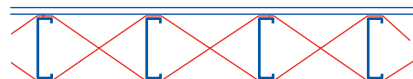

- solid blocking provided to every third pair of joists with ties between



- joists alternately reversed and tied together in pairs

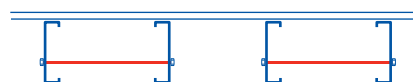

- joists alternately reversed and continuous ties (e.g. resilient bar) fixed to the joist flanges.



Where joists bear onto steelwork or are supported by cleats, blocking is not necessary adjacent to the supports.

**(i) alterations**

Joists should only be altered with the approval of the designer. Welded or flame cut edges should be cleaned and treated with a zinc-rich paint to prevent corrosion.

**6.10 - S11 Joists shall be drilled or holes punched within recognised limits**

The flanges of a light steel joist should not be notched unless in accordance with the design.

Drilling or punching through the web should only be carried out within recognised limits.

Unstiffened holes through the web should be carried out within the following limits:

- a rectangular hole or slot should not exceed 40% of the overall depth of the member. The length of the hole should not exceed three times the depth of the hole
- the diameter of circular holes should not exceed 60% of the depth of the member
- unstiffened holes should be at least the depth of the member apart and at least 1.5 times the depth from the end of the member.

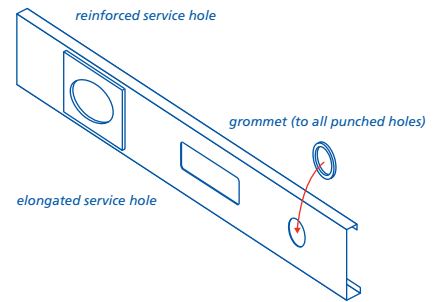

**6.10 - S12 Restraint strapping shall be provided in accordance with the design**

Where external walls, not constructed from light steel framing, are to be stabilised by a connection to the floor, straps may be required. Straps will generally be fixed to the web of the joist, to suit the masonry courses.

Where joists run parallel to the wall, straps should be supported on noggings fixed between the joists. Straps should be placed at a maximum of 2m apart and carried over three joists. Packing should be provided between the wall and the first joist.

Straps should be fixed with suitable bolts, screws or rivets and should bear on the centre of bricks or blocks, not across mortar joints.

**6.10 - S13 Overlapping joists shall be properly fixed to prevent disruption of finishes**

Where joists overlap on loadbearing intermediate walls they should be fixed together with bolts or screws to prevent the floor decking being pushed up or the ceiling being cracked when the cantilevered part of the joist moves upwards.

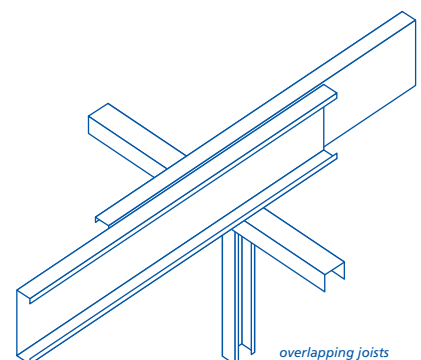

**6.10 - S14 Continuous joists shall be reinforced in accordance with the design**

Where joists are continuous over loadbearing intermediate walls, they should be reinforced as required by the design.



# 6.10 Light steel framed walls and floors

## 6.10 - S15 Floor decking and ceilings shall be adequately fixed

Items to be taken into account include:

### (a) decking

Flooring should be attached using self-drilling, self-tapping screws, ring shank nails or other approved fixings in accordance with the design at centres not more than 300mm. T&g joints should be glued.

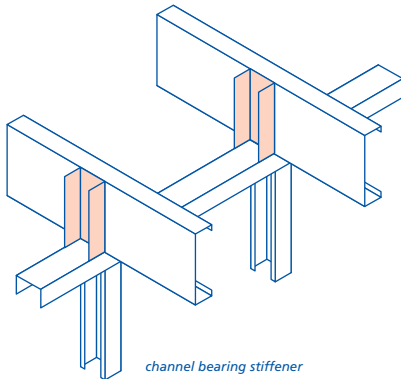

### (b) ceilings

Plasterboard should be fixed in accordance with Chapter 8.2 'Wall and ceiling finishes' (Sitework) using self-drilling, self-tapping screws.

Other ceiling boards should be fixed in accordance with the manufacturer's recommendations.

## SEPARATING FLOORS

### 6.10 - S16 Construction of separating floors shall ensure adequate sound insulation

The floating part of a floor should be completely separated from the main structure and surrounding walls by a resilient layer.

All joints should be glued where boards are laid loose over insulation without battens.

## SERVICES

### 6.10 - S17 Services shall be adequately protected from damage

Services and service outlets should be installed in accordance with the design.

Light steel studs should not be notched to accommodate services. Holing of structural light steel members should only be carried out as detailed in the Clause 6.10 - S11 unless approved by the designer. Welded or flame cut edges should be cleaned and treated with zinc-rich paint to prevent corrosion.

Cutting of service holes on site should be avoided since badly cut edges can have an adverse effect on the durability of the frame and may cause damage to pipes and cables.

Grommets should be used around the edge of service holes to protect electrical cables and reduce the risk of bimetallic corrosion between the light steel framing and copper pipes.

Swaged holes will not require grommets for the passage of electric cables and plastic piping.

In Scotland services are not permitted within a separating wall cavity.

## CONTROL OF FIRE

### 6.10 - S18 Fire spread shall be controlled as detailed in the design

Items to be taken into account include:

#### (a) walls

Walls should be constructed in accordance with the design and relevant Building Regulations to achieve the necessary fire resistance.

#### (b) floors

Floors should be constructed in accordance with the design and relevant Building Regulations to achieve the necessary fire resistance.

#### (c) cavity barriers and fire-stops

Cavity barriers and fire-stops should be installed in positions detailed by the design and relevant Building Regulations.

Service penetrations in floors between dwellings should be fire-stopped. There should be no holes or gaps for smoke to penetrate once the fire-stopping has been installed.

- A detailed description of the system
- Details of any limitations of its use
- Information for reference by the designer and steel frame project certifier.

\* The manufacturer is the company which assembles the steel frame sections to form the wall and/or floor panels.

If in doubt consult with NHBC Technical.

### Stage 2 - Project certification

NHBC requires the builder to appoint a steel frame project certifier to check the specific design of the steel framed housing on the specific site.

The steel frame project certifier will ensure that the proposals are in accordance with:

- The manufacturer's system certificate issued by SCI, and
- NHBC Standards Chapter 6.10 'Light steel framed walls and floors'.

In order to provide confirmation that both documents have been satisfied for a specific project, the steel frame project certifier will need to check supporting details and calculations.

If satisfied that the specific project details are satisfactory, the steel frame project certifier will issue a 'project certificate' to the builder.

Project certificates can only be issued by steel frame certifiers who have been approved by NHBC\*.

The project certificate should be made available on site for inspection by NHBC.

\* Applications to become a steel frame certifier should be made to NHBC Standards & Technical, Davy Avenue, Knowlhill, Milton Keynes MK5 8FP.

## APPENDIX 6.10-A

### Certification procedure

This Appendix outlines the two-stage certification process required by NHBC for light steel framed housing:

#### Stage 1 - System certification

NHBC requires manufacturers\* of steel frame systems forming loadbearing wall and floor panels to submit details in the form of a system manual, to the Steel Construction Institute (SCI), Silwood Park, Ascot, Berkshire, SL5 7QN for assessment.

The system manual must contain all of the information shown in Table 1 (overleaf). Where there are choices (e.g. types of claddings) the manufacturer will need to specify which options the SCI is to consider in its assessment.

The SCI will, upon satisfactory completion of the assessment, issue a numbered 'system certificate' and approve the manufacturer's system manual. The system certificate issued by the SCI will include the following information:

**Table 1 - Information to be contained in the system manual**

This table outlines the minimum information that should be provided in the system manual. The SCI may ask for additional information.

Topic	Description
Description of system	Key features
Application	The use(s) to which the system can be put, e.g. max number of storeys, type of cladding
Durability	Confirmation that design life is at least 60 years Grade of steel Corrosion protection Supplementary protection
Strength and stability	Structural design philosophy including Codes of Practice referenced and test reports Grade of steel (traceability) Section properties Loading Ultimate Limit State Serviceability Limit State Resistance to overturning Racking resistance Holding down Connections Structural integrity Positions and sizes of holes through members
Claddings	Which claddings are acceptable? Provision of cavity Type of wall ties
Behaviour in relation to fire	Which internal linings are necessary? Fire-stops and cavity barriers
Condensation risk	Type, thickness and location of insulation material
Sound insulation	Does specification comply with Building Regulations/Robust Details?
Balconies, terraces, and parapets	Any specific design considerations
Other	Other information of relevance to the designer and steel frame certifier

## INDEX

<b>A</b>		<b>G</b>		<b>S</b>	
Accuracy	6	Ground floors	3	Separating walls	8
Alterations	6, 8, 9	<b>H</b>		Services	4, 10
<b>B</b>		Holding down	5	Setting out	6, 8
Breather membranes	2, 5, 7	<b>I</b>		Sheathing	5
<b>C</b>		Insulation	2, 5, 7	Sound insulation	4, 10
Cavities	2, 7	<b>J</b>		Steel	1, 4, 8, 9
Cavity barriers and fire-stops	4, 5, 10	Joists	2, 8	System Certification	4, 10
Claddings	2, 6, 7	<b>L</b>		<b>T</b>	
Compatibility	1, 4	Loadbearing walls	1	Thermal insulation	5
Connections	1	<b>M</b>		<b>V</b>	
Connectors	5	Moisture control	2	Vapour control layers	5, 7
Control of fire	4, 10	<b>N</b>		Ventilation (of voids)	3
<b>D</b>		Non-loadbearing walls	1, 8	<b>W</b>	
Deflection	3	<b>P</b>		Wall ties and fixings	2, 5, 7
Design	1	Plasterboard	5		
Dpc and dpm	2, 5	Project certification	4, 10		
<b>F</b>		<b>R</b>			
Fixings	4, 5, 6, 7	Restraint strapping	9		
Floor decking	3, 5, 10	Roll	3, 9		
Floors	2, 3, 4				

---

# Part 7

## Roofs

---

7.1 Flat roofs and balconies

7.2 Pitched roofs



# Chapter 7.1

## Flat roofs and balconies

---



## CONTENTS

	Clause	Page
<b>DESIGN</b>		
Design standards	D1	1
Statutory requirements	D2	1
Loadbearing structure	D3-D4	1
Principles of design	D5	2
Structural deck	D6	2
Thermal insulation and vapour control layers	D7	2
Waterproofing and surface finishes	D8	2
Rainwater drainage	D9	2
Guarding to balconies	D10	3
Access for maintenance	D11	3
Provision of information	D12-D13	3
<b>MATERIALS</b>		
Materials standards	M1	3
Waterproofing	M2	4
Structural timber	M3	4
Profiled metal	M4	4
Green and proprietary roofs	M5	4
<b>SITWORK</b>		
Sitework standards	S1	4
In-situ reinforced concrete	S2	4
Precast concrete	S3	4
Profiled metal	S4	4
Timber	S5	5
Structural decks	S6	5
Drainage	S7	6
Thermal insulation and vapour control layers	S8	6
Waterproofing	S9	6
Guarding to balconies	S10	7
Protection of materials from weather	S11	7
<b>APPENDIX 7.1-A</b>		
Commonly used flat roofs		8
<b>APPENDIX 7.1-B</b>		
Surface treatments		13
<b>APPENDIX 7.1-C</b>		
Construction details of flat roofs and balconies		14
<b>APPENDIX 7.1-D</b>		
Balcony access, weatherproofing and drainage		16
<b>INDEX</b>		18

## SCOPE

This Chapter gives guidance on meeting the Technical Requirements and recommendations for flat roofs and balconies with a fully supported continuous weatherproofing membrane.

## DESIGN STANDARDS

### 7.1 - D1 Design shall meet the Technical Requirements

Design that follows the guidance below will be acceptable for flat roofs and balconies.

For the purposes of this Chapter:

- generally, a flat roof has a maximum slope of 10° from the horizontal; however, many flat roof systems can be used at greater pitches, in some cases up to vertical. Specifications for sloping roofs are generally the same as for flat roofs, but will require mechanical fixings to hold the materials in place
- "deck" is the structural substrate of a flat roof
- "decking" is the upper trafficked surface of a balcony (commonly a hardwood assembly laid onto the roof or substantial paving tiles bedded to the surface).

Note: Profile sheeted roofing acting as the waterproofing is outside the scope of this Chapter because it is discontinuous and not continuously supported.

## STATUTORY REQUIREMENTS

### 7.1 - D2 Design shall comply with all relevant statutory requirements

Designs should be in accordance with relevant Building Regulations and other statutory requirements.

## LOADBEARING STRUCTURE

### 7.1 - D3 Flat roofs and balconies, including associated elements such as support and guarding, shall be designed to resist the applied loading and have adequate durability

Structural design shall be undertaken in accordance with a recognised standard.

Items to be taken into account include:

#### (a) dead and imposed loads

Dead and imposed loads should be calculated in accordance with BS EN 1991-1-1, BS EN 1991-1-3 and BS EN 1991-1-4. Where a flat roof is to act as a roof terrace, roof garden or car parking area, appropriate provision should be made for the additional loadings. Intensive green roofs should only be used in conjunction with concrete decks.

#### (b) wind loads

Wind loads appropriate to the site should be calculated in accordance with BS EN 1991-1-4. The design should resist uplift from wind forces either by anchorage to the main structure or by being of sufficient weight to prevent lifting. Holding down straps, where required, should be provided

at 2.0m centres (maximum) (see Sitework clause 7.1 - S5(d)).

#### (c) durability

Technical Requirement R3 states that the structure shall, unless specifically agreed otherwise in writing with NHBC, have a life of at least 60 years.

The use of timber in balconies should be limited to secondary elements which in turn are supported by materials other than timber. Timber can be used in the following situations provided it has the appropriate durability - see Chapter 2.3 'Timber preservation (natural solid timber)':

- cantilevered solid timber joist balconies with a waterproof membrane above the joists
- open balcony constructions with timber decking. The decking may be supported on solid timber joists which in turn are supported by materials or components other than timber
- balustrading.

Timber should not be used for:

- gallow brackets supporting a balcony
- posts or columns supporting a balcony
- guard rails or their support.

### 7.1 - D4 Structural design shall be undertaken to a recognised standard to ensure that loads are transmitted to the supporting structure without undue movement

Items to be taken into account include:

#### (a) timber (where appropriate)

Structural design should be in accordance with one of the following:

- BS EN 1995-1-1
- appropriate load/span tables published by TRADA in support of Building Regulations and associated documents
- I-joists and metal web joists should be specified in accordance with the manufacturer's recommendations, but not used in situations where any part of the joist is exposed to external conditions.

Joist hangers should be the correct size for the timber joists being supported and meet with BS EN 845.

Pre-drilled vertical holding down straps should be at least one metre long, and 30mm x 2.5mm in cross section.

All mild steel straps and fixings should be protected against corrosion in accordance with Tables A.1 and A.2 of BS EN 845-1.

See clause 7.1 - D3 for guidance on the use of timber in balcony construction.

Reference should be made to Materials clause 7.1 - M1 and Chapter 2.3 'Timber preservation (natural solid timber)' (Design) for timbers requiring preservative treatment.

#### (b) in-situ reinforced concrete

In-situ reinforced concrete construction should be designed in accordance with BS EN 1992-1-1 and, where appropriate, Chapter 2.1 'Concrete and its reinforcement'. A concrete mix with low shrinkage characteristics should be specified.

#### (c) precast concrete

Precast concrete construction should be designed in accordance with BS EN 1992-1-1.

The design of concrete elements should allow for the following:

- continuity or anti-crack reinforcement
- allowance for movement at about 15m intervals and at abutments.

#### (d) profiled metal

The manufacturer's load/span tables for each profile should be consulted and should include the relevant applied safety factor. Profiled metals used for roof decks should have a profile with crowns of at least 50% of the profile width (not the sheet width) for bonded systems and 45% for mechanically fixed systems, in order to provide adequate support for the remainder of the roof build-up.

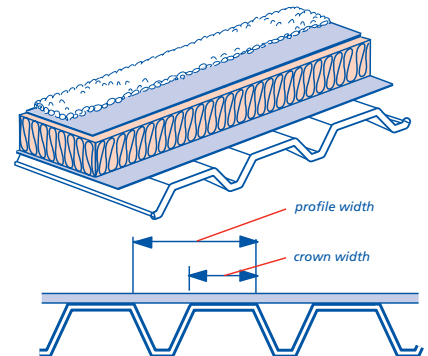

crown width to be not less than 50% of the profile width for bonded systems and 45% for mechanically fixed systems.

Construction loadings, including point loads imposed by foot traffic, storage of materials and loads imposed by following trades should be taken into account. Protection sheets, such as plywood, should be used to prevent damage if such loadings are expected.

Fixing to the structure should be in accordance with the manufacturer's instructions and BS EN 1991-1-4. Unless the manufacturer agrees otherwise, the deck should be side stitched to ensure it performs as a continuous plane layer.

The frequency of fixings should meet the manufacturer's recommendations, and be calculated to resist the wind uplift figures derived from BS EN 1991-1-4.

#### (e) structural steelwork

Structural steelwork should be designed in accordance with BS EN 1993-1-1 and

Technical Requirement R5. Supporting steelwork and purlins should be square, true and free from twists or sagging.

**(f) differential movement**

Allowance should be made for movement in larger roofs (e.g. roofs to blocks of flats), particularly where the span of the roof deck changes, e.g. in L-shaped buildings. Joints should be continuous through the vertical upstands, walls and edges of the building. Details are shown in Appendix 7.1-C.

**(g) lateral restraint**

Where walls require lateral restraint, this may be provided by joists and concrete roof elements. The bearings for concrete elements and timber joists where they are built in should be at least 90mm.

Where joists or concrete beams are parallel to walls, restraint straps at 2m centres (maximum) should be provided.

**(h) sound transmission**

Where the roof is a terrace above another dwelling, care should be taken to ensure that the design is in accordance with relevant Building Regulations.

## PRINCIPLES OF DESIGN

**7.1 - D5 Flat roofs shall be to a recognised design**

Appendix 7.1-A shows the three flat roof constructions acceptable to NHBC with variations for timber and concrete structural support.

They are:

warm roof	- concrete deck
	- timber deck
	- profiled metal deck
inverted warm roof	- inverted concrete deck
green roof	- intensive*
	- extensive*

\* A green roof should be a complete system from the membrane manufacturer and not individual components or materials.

The details for green roofs in Appendix 7.1-A are intended to be a guide and may vary depending on the individual manufacturer's system.

Cold roofs are not recommended, due to the difficulty of providing:

- an effective vapour control layer at ceiling level
- the required level of ventilation
- an unobstructed ventilation space above the insulation of 50mm
- ventilation at both ends of each joist void.

## STRUCTURAL DECK

**7.1 - D6 Flat roof decks shall be of adequate strength and moisture resistance**

Deck materials suitable for the different types of roof design are given in Appendix 7.1-A.

## THERMAL INSULATION AND VAPOUR CONTROL LAYERS

**7.1 - D7 Flat roofs (and balconies functioning as roofs) shall have adequate thermal insulation**

The BRE Report "Thermal insulation: avoiding risks" discusses aspects of insulation relevant to flat roofs and balconies. In England and Wales account should be taken of "Accredited Details".

Thermal insulation materials suitable for the different types of roof design are given in Appendix 7.1-A together with materials for vapour control layers and their position in the construction. The insulation material for inverted roofs should be suitable for external use and to withstand any anticipated traffic.

Where insulation is mechanically fixed the fixings should be of sufficient length to ensure they have adequate penetration into the supporting structure.

## WATERPROOFING AND SURFACE FINISHES

**7.1 - D8 Flat roofs (and balconies functioning as roofs) shall adequately resist the passage of moisture to the inside of the building**

The roof coverings and surface finishes suitable for different types of roof design are given in Appendices 7.1-A, 7.1-B, 7.1-C, 7.1-D.

Appendix 7.1-A includes typical details suitable for the following:

- built-up Reinforced Bitumen Membrane (RBM) roofing (formerly called "felt")
- mastic asphalt roofing
- single-ply roofing systems
- green roofs (intensive and extensive).

Appendix 7.1-B includes details of surface treatments.

Appendix 7.1-C includes typical details for flat roofs and balconies.

Appendix 7.1-D includes guidance for balcony waterproofing and drainage.

### GREEN ROOFS

Intensive and extensive green roofs are shown in Appendix 7.1-A. The details in Appendix 7.1-A are intended to be a guide and may vary depending on the individual manufacturer's system.

The manufacturer of the membrane system for a green roof should confirm that the overall roof design is compatible with the system. The complete green roof should be installed by a contractor trained and approved by the membrane manufacturer.

Once completed the waterproof membrane should be visually inspected and electronically tested for waterproofing integrity, faults rectified, and the roof re-tested before further layers, such as reservoir or filter layers and the subsoil and topsoil are placed. The tested membrane should be protected from damage until subsequent layers are applied.

The results of the test should be made available to NHBC.

The waterproofing for an intensive roof should be of reinforced bitumen membrane (RBM) or mastic asphalt and the design should include protection of the membrane from possible damage during maintenance of the garden e.g. from weeding/planting. A filter layer should be placed above the reservoir layer in accordance with the manufacturer's recommendations.

### OTHER FLAT ROOF COVERINGS

These are given in Materials clause M1 and should be used in accordance with the following:

- zinc sheet CP143-5 'Code of Practice for sheet roof and wall coverings'
- copper sheet CP143-12 'Code of Practice for sheet roof and wall coverings'
- lead sheet BS 6915 'Design and construction of fully supported lead sheet roof and wall coverings'.

## RAINWATER DRAINAGE

**7.1 - D9 Flat roofs (and balconies functioning as roofs) shall have adequate rainwater disposal to a suitable outfall**

Items to be taken into account include:

**(a) falls**

**GENERAL**

Other than the exceptions given below, all flat roofs (and balconies functioning as roofs) should be designed with a fall of not less than 1:40. A fall of 1:40 should be used for the design of flat roofs and balconies, unless a detailed analysis of the roof is carried out including overall and local deflection, to ensure the finished fall is not less than 1:80. Open slatted balcony decking should drain away from the dwelling.

Allowance for deflection should be made in the structural design where falls are achieved using screeds, particularly on large roofs.



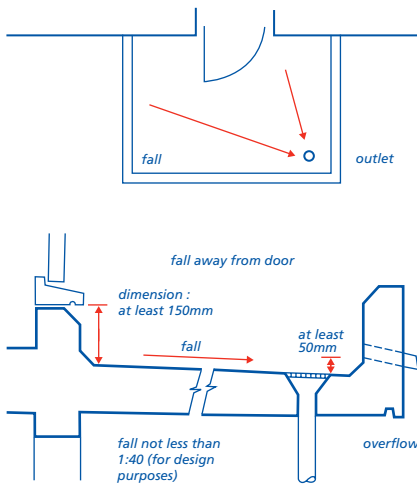

Where decking or paving to a balcony is to be installed above the waterproofing but less than 150mm below the sill, it should be of a type and design that prevents a build-up of standing water (see Appendix 7.1-D).

#### TAPERED INSULATION TO ACHIEVE FALLS

Drainage falls to warm-decked roofs using tapered insulation should be designed by the insulation manufacturer, with falls of not less than 1:60. They should be laid directly onto the vapour control layer, with the primary waterproofing above. Cross-falls should be achieved using mitred joints.

#### METAL SHEET ROOFS

Flat roofs with metal sheet roof coverings should be designed with a fall of not less than 1:30 to ensure a finished fall of not less than 1:60.

#### GREEN ROOFS

Green roofs should be designed to retain some water, to support and nurture the vegetation, and to manage the run-off, but the waterproofing should have falls of not less than 1:60 or in accordance with the system manufacturer's recommendations.

#### (b) outlets

The size and number of outlets should be designed to meet the expected rainfall intensity in accordance with BS EN 12056-3. For flat roofs bounded by parapets at least two outlets (or one outlet plus an overflow) should be provided. Outlets should have a recessed mouth to allow the free flow of water.

Rainwater drainage design is covered in Chapter 7.2 'Pitched roofs'. Reference should be made to Chapter 5.3 'Drainage below ground', where necessary. The roof design should incorporate rainwater outlets from flat roofs that are accessible for maintenance. For green roofs an accessible and visible inspection hatch should be provided at every outlet.

#### (c) prevention of flooding

Where a flat roof or balcony has an upstand on all sides, an overflow outlet should be provided through parapet walls or perimeter upstands to prevent a build-up of water in the event of other outlets becoming blocked. The position and height of the overflow should be such that any build-up of water will not enter the building. The capacity of the overflow should not be less than the size of the outlet (or the aggregated capacity of the outlets, if there are several outlets).

### GUARDING TO BALCONIES

#### 7.1 - D10 Balconies and flat roofs to which persons have regular access other than for maintenance shall be guarded adequately

Items to be taken into account include:

##### (a) provision of guarding

Guarding should be designed as follows:

- the balustrading should not be easily climbed
- any glazing in the balustrading should be toughened or laminated glass or glass blocks
- balustrading should not be fixed through the waterproofing unless special precautions are taken (see Appendix 7.1-C).

##### (b) stability of guarding

Parapet walls and balustrading should be designed to resist horizontal loading as required by the relevant Building Regulations or BS EN 1991-1-1. Particular care is needed when the design incorporates balustrading fixed to parapet walls to ensure stability and prevent overturning. End fixings or returns may be needed to ensure stability.

In balcony walls (especially long balconies) the structural stability should be checked as the dpc at the base of the wall can create a slip plane that can seriously limit the ability of the wall to resist horizontal forces. In such cases, it may be necessary to incorporate a ring beam or other support to ensure stability.

In the design of parapet walls, movement should be allowed for. Reference should be made to Chapter 6.1. 'External masonry walls' clause D3(g).

### ACCESS FOR MAINTENANCE

#### 7.1 - D11 Adequate access shall be provided to flat roofs for the purpose of maintenance

Provision should be made for safe future access to flat roofs for the purposes of maintenance.

### PROVISION OF INFORMATION

#### 7.1 - D12 Designs and specifications shall be produced in a clearly understandable format and include all relevant information

Clear and fully detailed drawings should be available on site to enable work to be carried out in accordance with the design. The drawings should include:

- the specification for intensive or extensive green roofs
- extent and direction of falls and position of outlets
- sections through the construction indicating how the falls are formed, and means of ventilation, if required
- size, specification and position of all the roof components, including the vapour control layer, insulation and waterproofing layer
- all treatment and protection of materials to achieve the necessary durability
- details of construction at critical junctions
- details of balustrading and method of fixing
- details of fixing methods and fixings for insulation and surfacing.

#### 7.1 - D13 All relevant information shall be distributed to appropriate personnel

Ensure that design and specification information is issued to site supervisors and relevant specialist subcontractors and/or suppliers.

### MATERIALS STANDARDS

#### 7.1 - M1 All materials shall:

- (a) meet the Technical Requirements
- (b) take account of the design

Materials that comply with the design and the guidance below will be acceptable for flat roofs and balconies.

Materials for flat roofs and balconies should comply with all relevant standards, including those listed below. Where no standard exists, Technical Requirement R3 applies (see Chapter 1.1 'Introduction to the Standards and Technical Requirements').

References to British Standards and Codes of Practice include those made under the Construction Products Directive (89/106/EEC) and, in particular, appropriate European Technical Specifications approved by a European Committee for Standardisation (CEN).

Appendix 7.1-A lists the materials suitable for:

- waterproofing, including flashings
- structure, deck and decking
- thermal insulation
- vapour control layer
- preservative treatment.

## WATERPROOFING

**7.1 - M2 Waterproofing materials shall be of adequate durability and resist the passage of moisture to the inside of the building**

### REINFORCED BITUMEN MEMBRANES, FORMERLY REFERRED TO AS "FELTS".

Only high performance reinforced bitumen membranes should be used, i.e. those including polyester reinforcement (e.g. Type 5U, 5B/180, 5E/250 to BS 747). Type 5 reinforced bitumen membranes are colour coded blue for identification.

### SINGLE PLY MEMBRANES (THERMOPLASTIC)

Examples of single layer materials include PVC (polyvinyl chloride) and TPO (thermoplastic polyolefine). These materials soften with increasing temperatures. Laps are welded, using either hot air or a specific solvent to melt and fuse them. These materials should be assessed in accordance with Technical Requirement R3.

### LIQUID SYSTEMS

These materials are applied as a liquid, often laid in two or more coats. Most include a reinforcement scrim to distribute the tensile stresses.

- cold-applied flexible polyurethane systems
- hot melt rubberised bitumen systems.

These are applied hot in two 3mm coats, with reinforcement between, and with a substantial reinforced bitumen membrane protection sheet. They should only be used in buried applications, such as inverted roofs, green roofs, podium areas, etc. These materials should be assessed in accordance with Technical Requirement R3.

### MASTIC ASPHALT

To BS 6925 type 988 T25, 20mm thick on the flat, laid on black sheathing felt.

For green roofs, three coats horizontally (30mm total thickness) and two coats vertically (20mm total thickness) are required.

Polymer modified asphalt waterproofing should be assessed in accordance with Technical Requirement R3.

Appendix 7.1-B gives suitable surface treatments for the waterproofing.

### SHEET METAL

Materials should be in accordance with the following:

- BS EN 501 'Specification for fully supported roofing products of zinc sheet'
- BS EN 504 'Specification for fully supported roofing products of copper sheet'
- BS EN 506 'Specification for self supporting products of copper or zinc sheet'

BS EN 12588 'Lead and lead alloys. Rolled lead sheet for building purposes'.

## STRUCTURAL TIMBER

**7.1 - M3 Structural timbers shall be of the appropriate grade and size to support the imposed loads**

Items to be taken into account include:

- appropriate load/span tables published by TRADA in support of Building Regulations and associated documents
- structural softwood for internal use should be dry graded to BS 4978 and marked 'DRY' or 'KD'.

I-joists and metal web joists should be specified in accordance with the manufacturer's recommendations. They should not be used in situations where any part of the joist is exposed to external conditions.

## PROFILED METAL

**7.1 - M4 Profiled metal roof decks shall be of the quality, type and dimensions required by the design**

Profiled metal roof decks should be:

- galvanised steel to BS EN 10147 and used in compliance with BS EN 1993-1-3, or
- aluminium to BS EN 485-2.

## GREEN AND PROPRIETARY ROOFS

**7.1 - M5 Green roofs and proprietary roofing systems shall be suitable for their intended use**

Green roofs, both intensive or extensive, should be a complete system from the membrane manufacturer and not individual components or materials.

The waterproofing for an intensive roof should be of reinforced bitumen membrane (RBM) or mastic asphalt.

The complete green roof should be installed by a contractor trained and approved by the membrane manufacturer.

Proprietary roofing systems, which do not meet with the principles given in Appendix 7.1-A, should be assessed in accordance with Technical Requirement R3.

## SITWORK STANDARDS

**7.1 - S1 All sitework shall:**

- (a) meet the Technical Requirements**
- (b) take account of the design**
- (c) follow established good practice and workmanship**

Construction that complies with the design and the guidance below will be acceptable for flat roofs and balconies.

## IN-SITU REINFORCED CONCRETE

**7.1 - S2 In-situ reinforced concrete flat roofs shall be constructed to ensure they achieve the required design, strength and durability**

Items to be taken into account include:

### (a) accuracy of formwork

The formwork should be constructed accurately.

Items to take into consideration are:

- accurate location of holes
- adequate support
- proper allowance for placing of steelwork
- cast-in features, such as drips and weatherchecks
- surface finishes.

Where a metal deck is used as permanent shuttering, drying of the concrete will take place from the top surface only. A temporary roof should be provided to allow drying to take place. The permanent waterproofing should only be installed when the deck has fully dried.

### (b) concrete grade

Reference should be made to Chapter 2.1 'Concrete and its reinforcement' for guidance on concreting. The design should have specified a concrete mix with low shrinkage characteristics.

## PRECAST CONCRETE

**7.1 - S3 Precast concrete flat roofs shall be constructed to ensure they achieve the required design, strength and durability**

The supporting structure should:

- be even and true
- have a minimum 90mm bearing for the pre-cast units unless the design shows a lesser dimension.

Precast units should be:

- installed to provide an even surface
- grouted, where required by the design.

## PROFILED METAL

**7.1 - S4 Profiled metal flat roofs shall be constructed to ensure they achieve the required design, strength and durability**

Items to be taken into account include:

### (a) material type and protection against corrosion

Sheets should be checked for conformity with the design and specification when they are delivered to site.

### (b) adequate storage

Profiled sheets should be stored to prevent:

- rusting of cut edges
- severe scratching of the galvanising
- sheets being bent or deformed.

**(c) fixings**

The number, type and location of fixings should be in accordance with the design and specification.

**(d) installation**

The supporting steelwork and purlins should be square, true and free from twists or sagging. Unless the manufacturer agrees otherwise, deck materials should be side stitched to ensure the deck performs as a continuous plane layer.

Assembly of the roof, end laps, etc. should be in accordance with the design; any variation from this should be approved by the designer.

Protection sheets, e.g. plywood, should be used in areas of the roof deck subjected to construction loadings, including point loads imposed by foot traffic and storage of materials. Loads imposed by following trades should be taken into account.

Any deformed sheets should be stripped and replaced, before the waterproofing and insulation system is installed.

**TIMBER**

**7.1 - S5 Timber flat roofs and (where appropriate) balconies shall be constructed to meet the required design, strength and durability**

Items to be taken into account include:

**(a) grades and sizes of joists**

Materials delivered to site should be checked for conformity with the design and specification.

**(b) the spacing and bearing required to achieve reasonably level support for furrings and deck**

Timber joists should be:

- level - where necessary, hard packing should be used, e.g. tiles or slates bedded in mortar. Loose or soft packing, including timber, should not be used
- spaced at the centres specified on the drawing (not more than 600mm centres).

The use of regularised timber joists will help to achieve a level deck.

**(c) strutting**

Strutting should be one of the following:

- herringbone type (timber 38mm x 38mm)
- solid blocking (38mm thick timber x ¼ depth of joist)
- proprietary steel strutting.

Strutting should be located as follows:

Joist span [m]	Rows of strutting
Up to 2.5	none needed
2.5 to 4.5	1 (at centre of span)
Over 4.5	maximum 2.5m centres, Spaced equally along the span

In cold deck roofs, the strutting should not prevent free cross ventilation.

**(d) holding down metal strapping**

If the design specifies holding down straps to prevent the roof being lifted off the supporting structure, they should be at 2.0m centres (maximum).

Where straps are fixed to masonry, hardened nails 4mm in diameter x 75mm long or No 12 wood screws x 50mm long into plugs should be used.

The number of fixings should be in accordance with design requirements and the lowest fixing should be within 150mm of the bottom of the vertical strap.

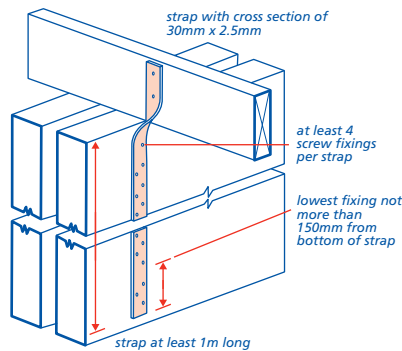

**(e) timber quality**

Timber should be rejected if it:

- is excessively bowed, twisted or cambered
- is excessively wet
- has large edge knots or shakes
- has a wane edge more than half the thickness
- has fissures
- has any sign of rot.

Where preservative treated timber has been cut after treatment the cut edges should be re-treated with a coloured preservative.

**(f) joist hangers**

The joist hanger should be the correct size for the timber joist or trimmer and nailed in accordance with the design.

The masonry course to carry the joist hangers should be level and at the correct height. The walling should not be cut into.

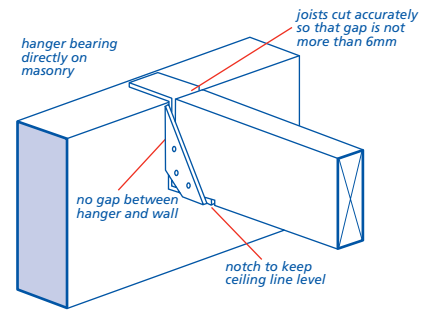

**STRUCTURAL DECKS**

**7.1 - S6 The structural deck shall be installed to form a satisfactory substrate for the waterproofing system**

Items to be taken into account include:

**(a) fixing of plywood and oriented strand board**

Tongued and grooved boards laid either with the long edge at right angles to the joists or parallel to the joists should have the short edge supported on a joist or noggings.

Oriented strand board should be laid over supports in the direction indicated on the boards. The stronger axis should be laid at right angles to the supporting joists.

Roof perimeter edges of boards which do not coincide with joists should be supported on noggings.

Unless the design specifies closer centres oriented strand board and plywood fixing centres should not exceed 100mm.

Movement gaps at abutment with rigid upstands should be not less than 10mm and gaps between square edge boards should not exceed 3mm.

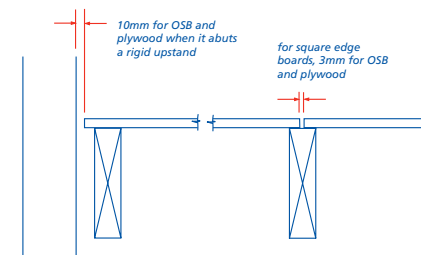

Oriented strand board should be fixed with flat headed ring shank nails, 3mm in diameter at least 2½ x board thickness long and not less than 9mm from the edge of the board.

Plywood should be fixed with ring shank nails, at least 50mm long x 3mm in diameter.

**(b) fixing of softwood boarding**

Softwood tongued and grooved boarding should be closely clamped together. Each board should be nailed with two ring shank nails to each joist or furring. Nail heads

should be punched below the timber surface. End joints should be staggered.

### (c) protection of structural deck

The deck should be installed in dry conditions and be protected from wetting until the roof is complete. The joints in sheet materials which are pre-felted or coated should be sealed immediately after fixing.

The area of deck installed in any working day should be no greater than can be quickly protected from wetting.

Damaged materials and materials that have been adversely affected by moisture should be discarded.

## DRAINAGE

### 7.1 - S7 Flat roofs shall have effective drainage

Falls and gutters should be constructed in accordance with the design. Flat roofs and balconies should have a finished fall of not less than 1:80 except flat roofs with metal sheet roof coverings and green roofs which should have a finished fall of not less than 1:60.

Appendix 7.1D provides guidance on weatherproofing and drainage of balconies

Items to be taken into account include:

#### (a) falls on concrete roofs

##### CEMENT/SAND SCREEDS

Cement sand screeds should be 1 : 4, cement : sand. Minimum screed thicknesses should be as follows:

Location of screed	Thickness [mm]
Bonded monolithically to insitu or pre-cast concrete	nominally 40mm (25mm minimum)
Unbonded (on separating layer)	nominally 70mm (50mm minimum)

Reference should be made to Chapter 8.3 'Floor finishes' for further guidance on laying screeds.

##### LIGHTWEIGHT SCREEDS

Lightweight screeds should be laid only by specialist contractors. Lightweight concrete screeds should have a topping of 1 : 6, cement : sand, 13mm thick.

##### SCREED FINISH

Screeds should be free from ridges and indentations. They should be finished with a wooden float to provide a smooth, even surface for the vapour control layer and waterproof finish.

#### (b) falls on timber roofs

Furring pieces should be used to form falls, unless the design shows sloping joists and

ceiling. Where laid across the joists, firrings should be not less than the following sizes:

Joist Centres [mm]	Minimum furring dimensions [mm]	
	width	depth
400 or 450	38	38
600	38	50

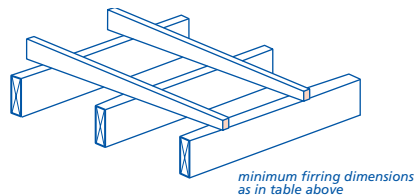

### (c) tapered insulation systems

The manufacturer's specific design and layout drawings should be followed. The sequence of installation should ensure that boards are waterproofed and the roof sealed at the end of each day, or before the arrival of inclement weather. Successive roof layers should be laid with a minimum of delay, to avoid trapping water during construction.

### (d) access to rainwater outlets

Rainwater outlets from flat roofs should be accessible. For green roofs an accessible and visible inspection hatch should be provided at every outlet.

## THERMAL INSULATION AND VAPOUR CONTROL LAYERS

### 7.1 - S8 Insulation and vapour control layers shall be installed in accordance with the design

Appendix 7.1-A gives details of suitable materials for insulation and vapour control layers for the different types of roof designs.

#### WARM ROOFS

The design should indicate that the vapour control layer is below the insulation and that it is sealed to the waterproofing at the perimeter and at all penetrations through the roof, e.g. at outlets and pipes. In single ply roofing systems the vapour control layer is generally not sealed to the waterproofing.

Insulation boards should be kept dry at all stages to prevent:

- lack of bonding
- trapping of moisture.

The area of insulation laid at any time should be that which can quickly be covered by the waterproofing or protected from wetting.

Insulation should be bonded or mechanically fixed in accordance with the manufacturer's recommendations.

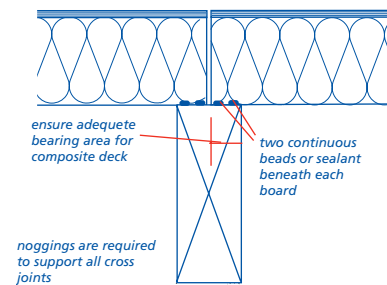

Composite decks require noggings under transverse edges. The joist width should be in accordance with the design to ensure the insulation has adequate bearing.

The foil underface of a composite deck should be sealed with two beads of sealant along all board joints to maintain the integrity of the vapour control layer.

#### INVERTED ROOFS

The insulation material for inverted roofs should be in accordance with the design, be suitable for external use and withstand any anticipated traffic.

#### GREEN ROOFS

Where the vapour control layer has been used as a temporary waterproofing layer any damage should be repaired using a full width section of membrane.

#### COLD ROOFS

Ventilation should be provided at both ends of each joist void, and should not be blocked by the thickness of the insulation.

A minimum of 50mm clear air space above the insulation should be maintained.

## WATERPROOFING

### 7.1 - S9 Waterproofing shall prevent water entering the building

Items to be taken into account include:

#### (a) preparation of surfaces

The structure and the surface to receive the waterproofing should be checked and approved by the waterproofing contractor. All nails should be well punched below the surface, which should be even and dry.

The manufacturer's recommendations on priming upstands, roof outlets, etc. should be followed to achieve a satisfactory bond with the waterproofing.

#### (b) construction sequence

Waterproofing systems should be laid in accordance with the design and specification following the recommendations of the manufacturer. Some proprietary systems should be laid only by specialist roofing contractors

approved by the manufacturer. See clause S9(d) for green roofs.

It is preferable for one contractor to lay the vapour control layer, the insulation, the waterproofing and the surface finish. The contractor should ensure that the deck and the insulation boards are waterproofed and the roof sealed at the end of each day, or before the arrival of inclement weather.

Successive roof layers should be laid so as not to trap water during construction.

Membrane laps near outlets should not impede drainage.

#### (c) weather conditions

The manufacturers' recommendations for conditioning, (unrolling in advance of laying, etc) should be followed.

Generally, sheet membranes should not be laid or handled when the air temperature is 5°C or below unless the manufacturer agrees otherwise. Some self-adhesive reinforced bitumen membranes should not be laid below 10°C. For such systems, the manufacturer's specific instructions should be followed.

Membranes should not be laid on damp or frosted surfaces or when any rain, sleet or snow is falling.

#### (d) green roofs

Green roofs should be laid in accordance with the design and the membrane manufacturer's recommendations, taking into account:

- root barriers
- height of upstand in relation to soil height and flashings
- integrity of waterproofing prior to burying
- protection, reservoir and filter layers
- moisture control of the soil.

Green roof systems should be installed by operatives who:

- are competent
- are familiar with the system being installed
- hold a certificate confirming they have been trained by the system membrane manufacturer or distributor.

#### (e) correct detailing

Appendix 7.1-C gives, for the different roof types, typical details of:

- abutments
- parapets
- edge details
- fixing of guarding
- projections through the waterproofing
- roof lights.

#### (f) balconies

Appendix 7.1D provides guidance on weatherproofing and drainage of balconies

## GUARDING TO BALCONIES

**7.1 - S10 Guarding to balconies shall be of adequate strength and height to minimise the risk of people falling, of adequate durability and fixed securely**

Items to be taken into account include:

#### (a) strength and movement of masonry balcony walls

Masonry balcony walls should be built in accordance with Chapter 6.1 'External masonry walls'. In particular:

- walls should incorporate strengthening as required by the design
- movement joints should be provided in accordance with the design
- copings should be firmly bedded.

#### (b) fixing of balustrading and guard rails

Balustrading and guard rails should be fixed in accordance with the design details. Reference should also be made to Appendix 7.1-C.

## PROTECTION OF MATERIALS FROM WEATHER

**7.1 - S11 Moisture sensitive material shall be protected from wetting**

Timber-based roof decking and insulation materials should be stored under cover to prevent wetting.

Timber-based roof decks that have been fixed in position should be temporarily covered to prevent wetting, unless the waterproofing is to be laid immediately.

Zinc coils and sheets should be stored in dry conditions before being installed.



### APPENDIX 7.1-A

#### Commonly used flat roofs

Three types of flat roof are shown here to illustrate the principles of their design:

WARM ROOF (insulation on top of deck)		
concrete deck	timber deck	profiled metal deck
<ul style="list-style-type: none"> <li>surface treatment*</li> <li>waterproofing</li> <li>insulation</li> <li>vapour control layer</li> <li>screed</li> <li>deck</li> </ul>	<ul style="list-style-type: none"> <li>surface treatment*</li> <li>waterproofing</li> <li>insulation</li> <li>vapour control layer</li> <li>deck</li> </ul>	<ul style="list-style-type: none"> <li>surface treatment*</li> <li>waterproofing</li> <li>insulation</li> <li>vapour control layer</li> <li>metal deck</li> </ul>
* mineral surfaced or solar reflective treatment where required		

INVERTED WARM ROOF (insulation on top of waterproofing)
concrete deck
<ul style="list-style-type: none"> <li>ballast</li> <li>filter layer</li> <li>insulation</li> <li>waterproofing</li> <li>screed</li> <li>deck</li> </ul>

GREEN ROOF	
intensive (requires regular maintenance. Plants contained within soil)	extensive (requires periodic maintenance. Plants generally contained in the sedum blanket)
<ul style="list-style-type: none"> <li>soil and vegetation (up to 1m deep)</li> <li>filter layer</li> <li>drainage/reservoir layer</li> <li>protection layer</li> <li>root barrier</li> <li>waterproofing</li> <li>insulation</li> <li>vapour control layer</li> <li>screed</li> <li>concrete deck</li> </ul>	<ul style="list-style-type: none"> <li>sedum blanket</li> <li>filter layer</li> <li>root barrier</li> <li>waterproofing</li> <li>insulation</li> <li>vapour control layer</li> <li>screed</li> <li>concrete deck (profiled metal decks may be an alternative depending on loadings)</li> </ul>

**WARM ROOF (concrete deck)**

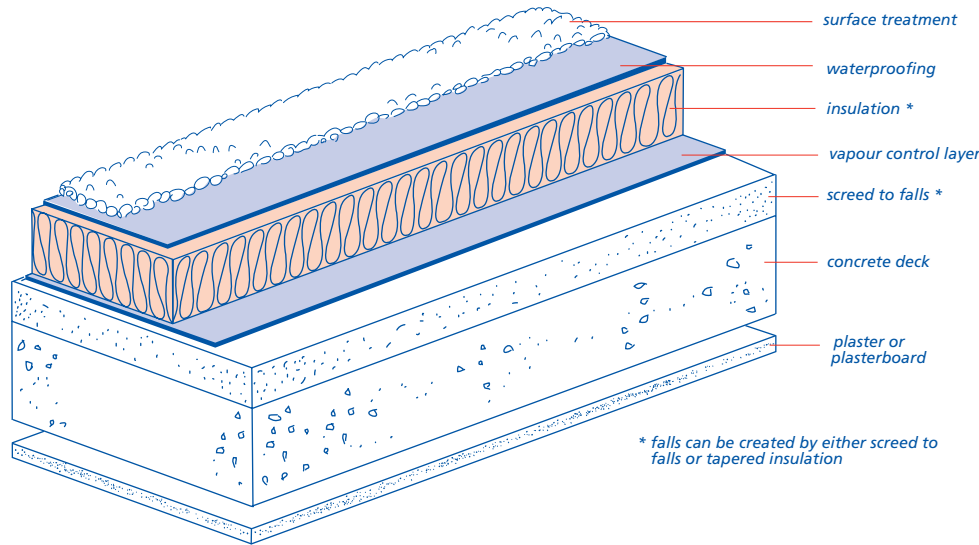

**Surface treatment**  
See Appendix 7.1-B

**Waterproofing and insulation**

Waterproofing should be one of the following:

- reinforced bitumen membrane (RBM) to BS 8747 from the following table:

Type of Reinforced Bitumen Membrane (RBM)			Insulation material	Method of fixing first layer
First/preparatory layer	Second layer/underlay	Final layer/cap sheet		
Type 3G perforated layer	S2P3	S5P5 with either integral mineral finish or separate solar protection	Rigid Urethane Foam (RUF) boards (polyurethane (PU) and polyisocyanurate (PIR))	Loose laid and lapped, to produce partial bonding.
Type 3G perforated layer	Elastomeric underlay achieving S2P3	Elastomeric capsheet achieving S5P5		
S2P3 fully bonded	S2P3	S5P5 with either integral mineral finish or separate solar protection	Compressed cork, rock fibre or glass fibre boards, cellular glass slabs, perlite boards, or composite products	Full bitumen bonding, per BS 8217
S2P3 fully bonded	Elastomeric underlay achieving S2P3	Elastomeric capsheet achieving S5P5		

Note: torching onto insulation boards, except rock/glass fibre or perlite is not acceptable.  
Note: Elastomeric (i.e. SBS polymer-modified) bitumen membranes, with greater extensibility and flexibility, especially at low temperatures, are likely to provide longer service life.

- mastic asphalt, 20mm thick on the flat, laid in two layers, all to BS 8218 onto black sheathing felt
- a thermoplastic single ply membrane, assessed in accordance with Technical Requirement R3, either bonded to the insulation, mechanically fixed to the deck through the insulation, or loose-laid, sealed and ballasted. Refer to the manufacturer's instructions for details.

**Vapour control layer**

The vapour control layer should consist of at least one layer of bitumen roofing membrane (S2P3) fully bonded to the structural deck and all laps sealed with bitumen.

**Concrete deck and screed**

Concrete roof deck, suitably primed, with sand/cement screed topping to achieve the falls. The screed should be in accordance with Clause 7.1-S7(a).

**Detailing**

Typical details are shown in Appendix 7.1-C.



### WARM ROOF (timber deck)

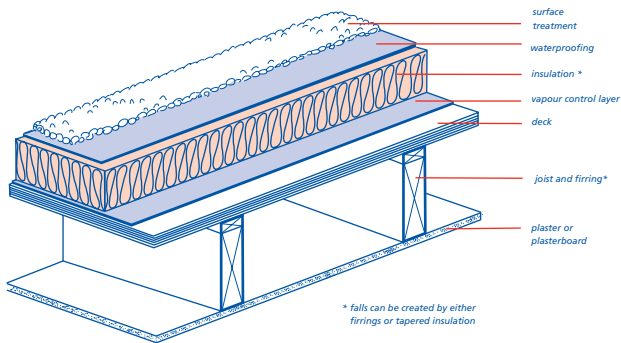

### WARM ROOF (profiled metal deck)

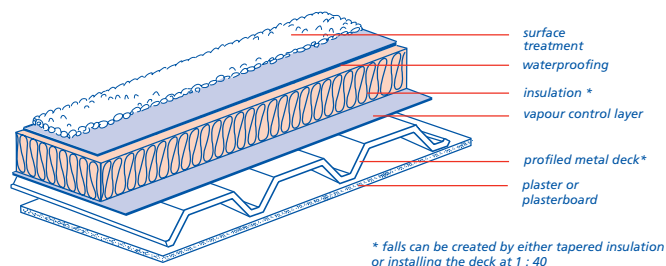

#### Surface treatment

See Appendix 7.1-B

#### Waterproofing and insulation

Waterproofing should be one of the following:

- reinforced bitumen membranes (roofing felt) to BS 8747 from the following table:

Type of Reinforced Bitumen Membrane (RBM)			Insulation material	Method of fixing first layer
First/preparatory layer	Second layer/underlay	Final layer/cap sheet		
Type 3G perforated layer	S2P3	S5P5 with either integral mineral finish or separate solar protection	Rigid Urethane Foam (RUF) boards (polyurethane (PU) and polyisocyanurate (PIR))	Loose laid and lapped, to produce partial bonding
Type 3G perforated layer	Elastomeric underlay achieving S2P3	Elastomeric capsheet achieving S2P3		
S2P3 fully bonded	S2P3	S5P5 with either integral mineral finish or separate solar protection	Compressed cork, rock fibre or glass fibre boards, cellular glass slabs, perlite boards, or composite products	Full bitumen bonding, per BS 8217
S2P3 fully bonded	Elastomeric underlay achieving S2P3	Elastomeric capsheet achieving S2P3		

Note: torching onto insulation boards, except rock/glass fibre or perlite is not acceptable.  
 Note: Elastomeric (i.e. SBS polymer-modified) bitumen membranes, with greater extensibility and flexibility, especially at low temperatures, are likely to provide longer service life.

- mastic asphalt, 20mm thick on the flat, laid in two layers, all to BS 8218 onto black sheathing felt
- a thermoplastic single ply membrane, assessed in accordance with Technical Requirement R3, either bonded to the insulation, mechanically fixed to the deck through the insulation, or loose-laid, sealed and ballasted. Refer to the manufacturer's instructions for details.

#### Vapour control layer

In bonded systems the vapour control layer should consist of at least one layer of bitumen roofing membrane (S2P3) fully bonded or nailed to the structural deck and all laps sealed with bitumen. In mechanically fixed systems the vapour control layer should consist of suitable polyethylene sheet sealed at all laps.

#### Preservative treatment

All roof timbers, joists, wall plates, blocking, strutting, battens, firrings, noggings to be preservative treated, unless naturally durable. Chapter 2.3 'Timber preservation (natural solid timber)' gives details of preservative treatments.

#### Deck

Timber or timber-based decks should be one of the following:

Material	Thickness of deck (mm)	
	Joist centres (mm)	
	450mm	600mm
Pre-treated plywood, WBP grade	15	18
Marine plywood, WBP grade	15	18
Oriented Strand board Type OSB3	15	18
Pre-treated timber planking - tongue and grooved ('close boarded timber') Max. board width 100mm.	19	19

Reference should be made to Sitework clause 7.1 - S6 for fixing of the deck to joists.

#### Joists

For sizes and spacing, reference should be made to appropriate load/span tables published by TRADA in support of Building Regulations and associated documents.

#### Detailing

Typical details are shown in Appendix 7.1-C

**INVERTED WARM ROOF (concrete deck)**

(NOT suitable for slopes greater than 10°)

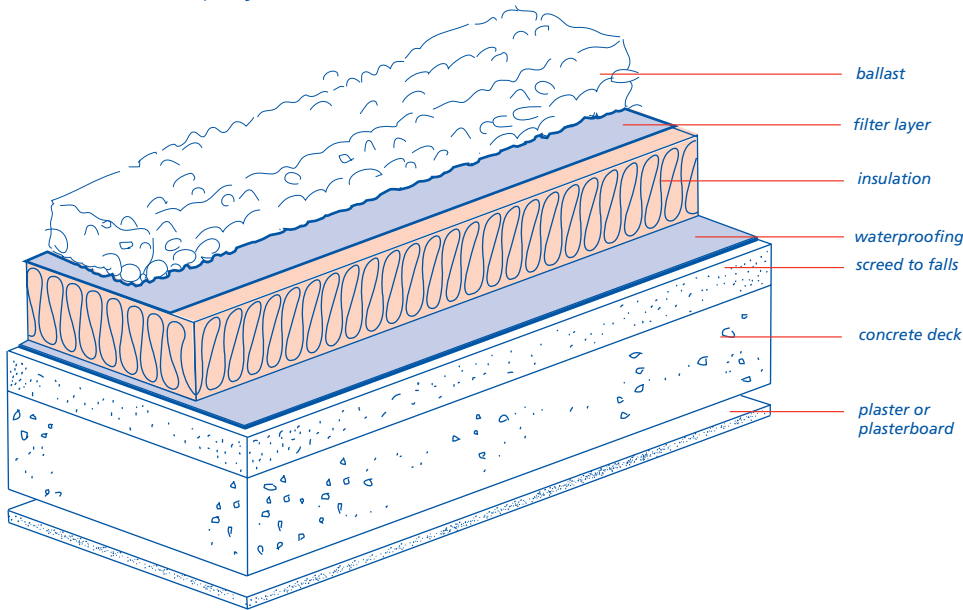

**Ballast**

Ballast should consist of paving slabs, or of rounded pebbles of minimum diameter 19mm to the depth specified in the design.

**Filter layer**

Geo-textile layer, laid over insulation boards to prevent fines from reaching the membrane surface.

**Insulation**

Insulation should be of a type unaffected by exposure to the weather and capable of supporting the weight of the ballast. Only the following materials are suitable:

- extruded polystyrene (XPS)
- extruded polystyrene, with cementitious surface.

**Waterproofing**

Waterproofing should be one of the following:

- reinforced bitumen membranes (roofing felt) to BS 8747 from the following table:

Type of Reinforced Bitumen Membrane (RBM)			Deck material	Method of fixing first layer
First/preparatory layer	Second layer/underlay	Final layer/cap sheet		
Type 3G perforated layer	S2P3	S5P5 with either integral mineral finish or separate solar protection	Concrete, or concrete with sand/cement screed	Loose laid and lapped, to produce partial bonding
Type 3G perforated layer	Elastomeric underlay achieving S2P3	Elastomeric capsheet achieving S2P3 Mineral surfaced on exposed upstands, etc.		

Note: Concrete or screeded substrates should be adequately dry to receive waterproofing system  
 Note: Elastomeric (i.e. SBS polymer-modified) bitumen membranes, with greater extensibility and flexibility, especially at low temperatures, are likely to provide longer service life

- mastic asphalt, 20mm thick on the flat, laid in two layers, all to BS 8218 onto black sheathing felt.
- a thermoplastic single ply membrane, assessed in accordance with Technical Requirement R3, either bonded or mechanically fixed to the deck, or loose-laid, sealed and ballasted. Refer to manufacturer's instructions for details.

**Concrete deck and screed**

Concrete roof deck, suitably primed, with sand/cement screed topping to achieve the falls. The screed should be in accordance with Clause 7.1-S7(a).

**Detailing**

Typical details are shown in Appendix 7.1-C.

Note:

Inverted roofs should only be used with timber (solid or I-joint) or metal profiled decks if they have been designed to support the loads, particularly from the depth of ballast needed to retain the insulation material.

### GREEN ROOF

A green roof, either intensive or extensive, should be a complete system from the membrane manufacturer and not individual components or materials. The details given below are intended to be a guide and may vary depending on the individual manufacturer's system. The following identifies the two types of green roof:

#### INTENSIVE

#### EXTENSIVE

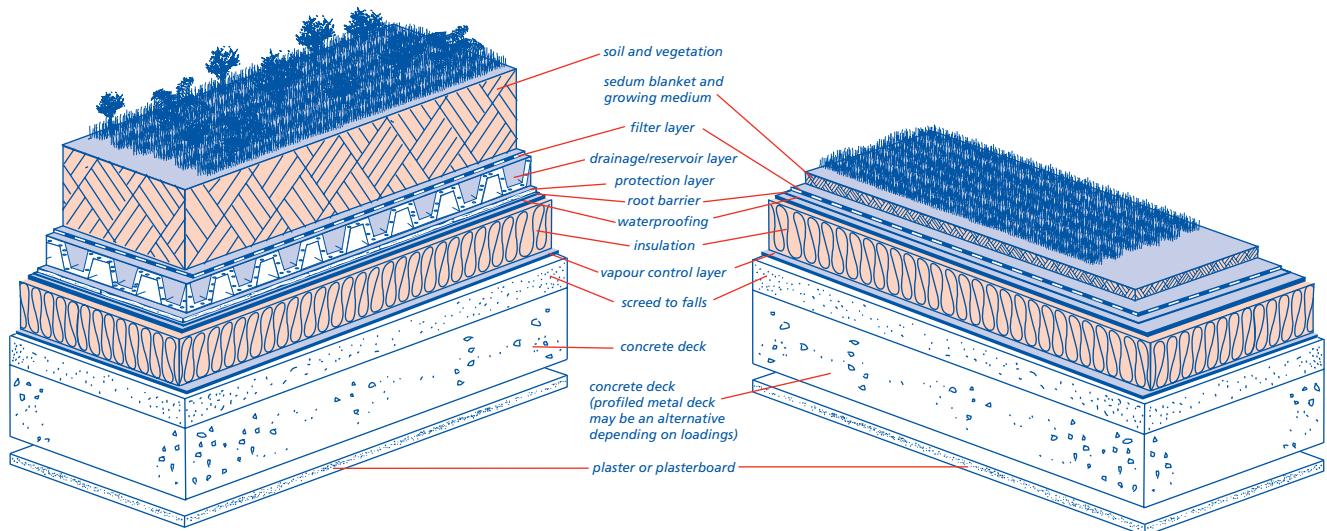

Summary	Intensive	Extensive
<b>Feature</b>	requires regular "intensive" maintenance e.g. similar to a normal garden provides a normal garden environment uses natural topsoil at least 150mm deep and normal plants	requires minimal maintenance e.g. annual attention a sedum blanket contains the plants
<b>Structure</b>	roof design to allow for full weight of wet soil 20° maximum roof pitch	roof loadings less than Intensive roof
<b>Falls and moisture control</b>	drainage falls 1:60min irrigation system may be required to support plants in dry spells	45° maximum roof pitch drainage falls 1:60min irrigation system may be required to support plants in drought conditions
<b>Vapour control layer</b>	Fully bonded polyester-reinforced RBM (S2P3)	Fully bonded polyester-reinforced RBM (S2P3)
<b>Insulation</b>	Insulation material to have adequate compressive strength to withstand likely applied loads Where the insulation is above the weatherproofing, only extruded polystyrene (XPS) should be used	Insulation material to have adequate compressive strength to withstand likely applied loads Where the insulation is above the weatherproofing, only extruded polystyrene (XPS) should be used
<b>Waterproofing</b>	See separate table. A root resistant element such as a copper foil or "Preventol" treatment is required above the waterproofing membrane	See separate table. A root resistant element such as a copper foil or "Preventol" treatment is required above the waterproofing membrane
<b>Protection and filter layers</b>	A filter layer and protection layer (or board), above the waterproofing membrane, is required to prevent damage. These to be in accordance with the manufacturer's recommendations	A filter layer and protection layer (or board), above the waterproofing membrane, is required to prevent damage. These to be in accordance with the manufacturer's recommendations

Type of Reinforced Bitumen Membrane (RBM)			Insulation Material	Method of fixing firstlayer
First/preparatory layer	Second layer/underlay	Final layer/cap sheet		
Type 3G perforated layer	S2P3	S5P5 with either integral mineral finish or separate solar protection	Rigid Urethane Foam (RUF) boards (polyurethane (PU) and polyisocyanurate (PIR))	Loose laid and lapped, to produce partial bonding.
Type 3G perforated layer	Elastomeric underlay achieving S2P3	Elastomeric capsheet achieving S2P3 Mineral surfaced on exposed upstands, etc.		
S2P3 fully bonded	S2P3	S5P5 with either integral mineral finish or separate solar protection	Compressed cork, rock fibre or glass fibre boards, cellular glass slabs, perlite boards, or composite products	Full bitumen bonding, per BS 8217
S2P3 fully bonded	Elastomeric underlay achieving S2P3	Elastomeric capsheet achieving S2P3 Mineral surfaced on exposed upstands, etc.		
Note: torching onto insulation boards, except rockwool or perlite is not acceptable. Note: Elastomeric (i.e. SBS polymer-modified) bitumen membranes, with greater extensibility and flexibility, especially at low temperatures, are likely to provide longer service life.				
Mastic Asphalt Mastic asphalt to BS 8218. Three coat horizontally (30mm total thickness), two coat vertically (20mm total thickness).				

APPENDIX 7.1-B

Surface treatments

	Maintenance only for roofs up to 10°	Access roof, walkway or terrace deck	Further information may be obtained from
<b>Reinforced Bitumen Membranes (RBM)</b>	<ul style="list-style-type: none"> <li>mineral surfaced capsheets (e.g. Type S5P5) or reflective stone chippings, bedded in a dressing compound, or</li> <li>a suitable thickness of washed, rounded 20 - 40mm shingle ballast laid loose</li> </ul>	<ul style="list-style-type: none"> <li>pre-cast semi porous concrete tiles bedded in bitumen or other approved adhesive, or</li> <li>pre-cast concrete proprietary paving slabs on supports or sand/cement blinding<sup>2</sup>, or</li> <li>proprietary timber decking systems 3</li> </ul>	Flat Roofing Alliance <a href="http://www.fra.org.uk/">www.fra.org.uk/</a>
<b>Mastic Asphalt</b>	<ul style="list-style-type: none"> <li>reflective stone chippings 1, bedded in a bitumen based compound, or</li> <li>a solar reflective paint, as approved by the Mastic Asphalt Council</li> </ul>	<ul style="list-style-type: none"> <li>pre-cast semi porous concrete tiles bedded in bitumen or other approved adhesive, or</li> <li>pre-cast concrete proprietary paving slabs on supports or sand/cement blinding<sup>2</sup></li> </ul>	Mastic Asphalt Council <a href="http://www.masticasphaltcouncil.co.uk/">www.masticasphaltcouncil.co.uk/</a>
<b>Thermoplastic Single Ply Membranes</b>	<ul style="list-style-type: none"> <li>products do not require supplementary solar reflective coatings or other finishes</li> <li>where laid loose, membranes can be ballasted with suitable thickness of washed, rounded 20-40mm shingle ballast laid on a non-woven polymeric protection layer</li> </ul>	<ul style="list-style-type: none"> <li>proprietary flexible, non-slip walkway sheets or tiles, compatible with the membrane product</li> <li>pre-cast concrete proprietary paving slabs on adjustable supports or suitable non-woven polymeric protection layer</li> <li>proprietary timber decking systems with bearers set on additional membrane or suitable non-woven polymeric protection layer</li> </ul>	Single Ply Roofing Association <a href="http://www.spra.co.uk/">www.spra.co.uk/</a>

Notes

- Loose surface finishes should be prevented from being removed by weather and discharged into gutters and drain pipes. Chippings should be not less than 12.5mm limestone or white spar, not pea gravel.
- Cement/sand blinding should be laid on two layers of waterproof building paper or two layers of 1000 gauge polyethylene separating membrane. The slabs should be kept back 75mm at perimeters and a 25mm movement gap incorporated for every 9m<sup>2</sup> of paving laid.
- Timber decking systems should only use compatible preservative treatments. The undersides of the bearers should have large, smooth contact areas, with no sharp edges or corners.

### APPENDIX 7.1-C

#### Construction details for flat roofs and balconies

This Appendix contains common details for flat roofs and balconies. The following sketches show examples of typical common construction details and illustrate general principles. Further information on specific waterproofing systems may be obtained from BS 8217 'Reinforced bitumen membranes for roofing - Code of Practice', the Flat Roofing Association, Mastic Asphalt Council or Single Ply Roofing Association.

#### CONCRETE DECK

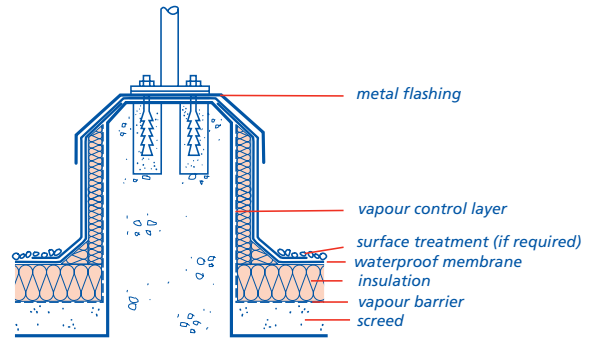
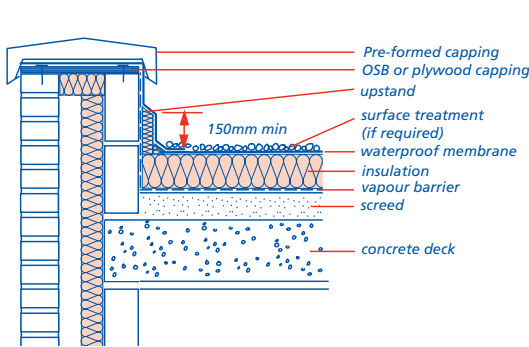

#### Upstand

- upstand may be fixed to wall
- upstand to be at least 150mm high
- similar details apply to inverted roofs with concrete decks

#### Handrail fixing

- upstand should be formed in concrete roofs

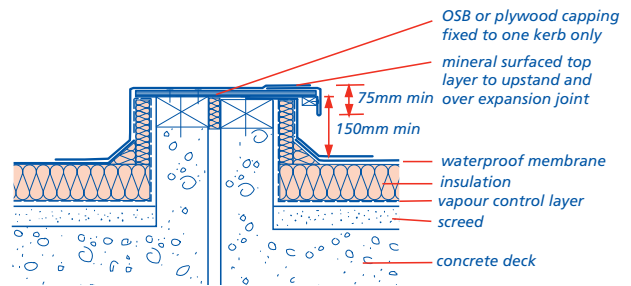
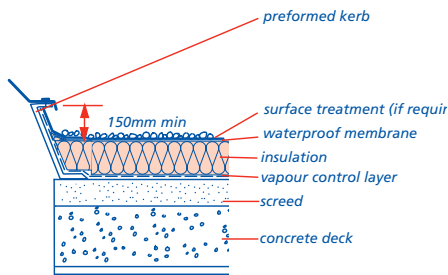

#### Skirting to rooflight or ventilator kerb

- similar details apply to inverted roofs. Allow for thickness of ballast to achieve upstand dimension.

#### Twin-kerb expansion joint

- expansion joint is similar for both warm and inverted concrete roofs.

#### TIMBER DECK

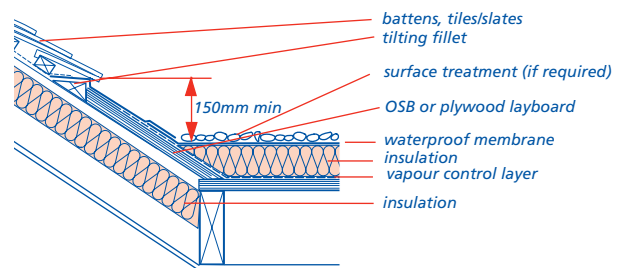
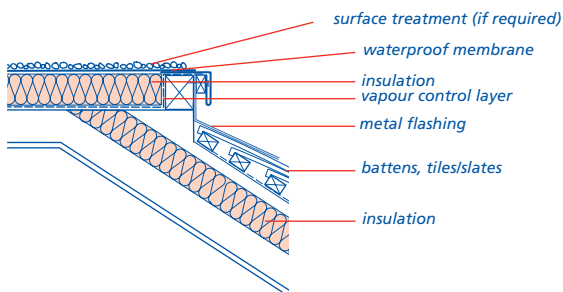

#### Mansard edge

- All elements should be firmly fixed to prevent peelback in high winds

#### Pitched roof abutment

**TIMBER DECK (Continued)**

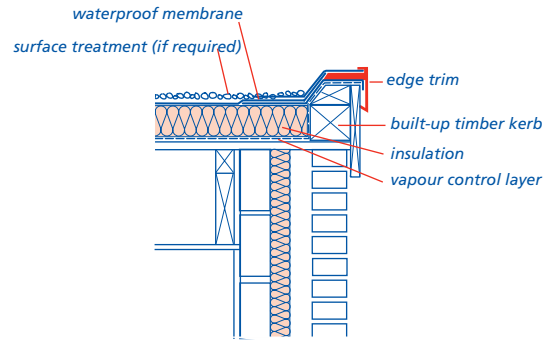
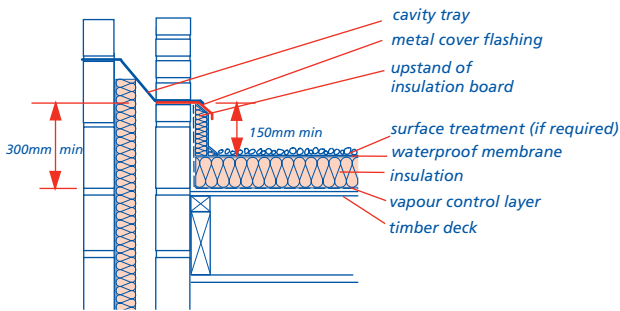

**Independent skirting detail**

- upstands should be kept separate from wall - allow for movement
- upstand should be at least 150mm high
- similar details apply to cold deck timber roofs

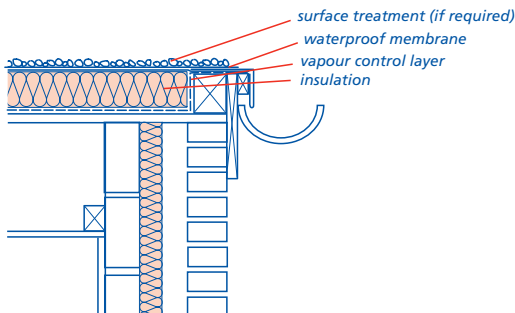

**Verge detail**

- similar details apply to inverted deck

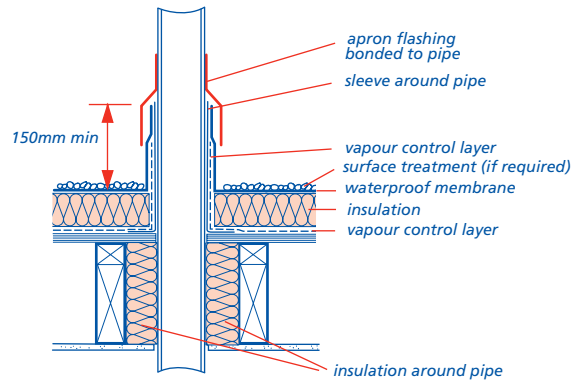

**Weltd drip to external gutter**

- similar details apply to cold deck timber roofs
- inverted timber decks need special consideration to avoid insulation being lifted by wind suction. An alternative detail should be used.

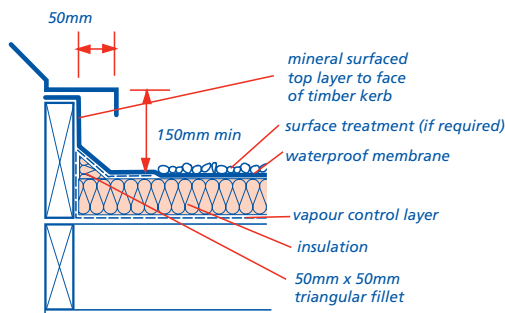

**Pipe passing through roof**

- vapour control layer should be bonded to waterproofing
- detailing of upstand and flashing is similar for all roofs

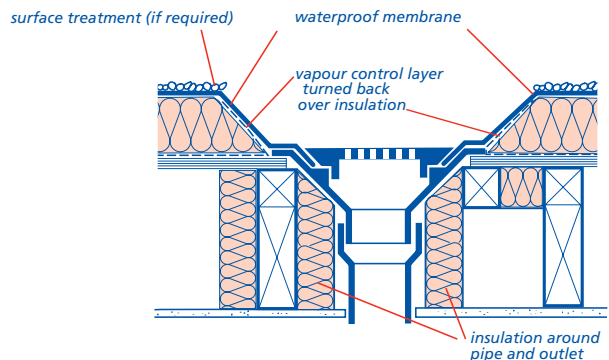

**Upstand to ventilator or rooflight kerb**

- similar details apply to cold and inverted roofs. The thickness of ballast in inverted roofs, to achieve upstand dimensions, should be allowed for.

**Rainwater outlet**

- the opening should be properly trimmed
- the outlet should be at the lowest point in roof
- similar details apply to concrete roof
- ensure outlet is fixed securely to decking to prevent displacement by thermal expansion of rainwater pipe.



## APPENDIX 7.1-D

**Balcony access, weatherproofing and drainage**

This Appendix contains guidance on the principles to adopt for the weatherproofing and drainage of balconies which may then have an accessible threshold. Depending on the design, specific fire, thermal and acoustic issues may also need to be taken into account.

The design and construction of accessible balcony thresholds should incorporate all of the following:

- **a door threshold with an upstand of not more than 15mm**

The 15mm threshold upstand is measured at the door position. Additional sloping transition elements, such as a small internal ramp and external sill, may be provided either side of the upstand. The maximum slope on ramps and sills should be 15 degrees.

- **a door threshold with a minimum 45mm projecting sill and drip.**

The sill should have a minimum 45mm overhang and drip to shed rainwater away from the interface between the waterproofing layer and the sill and to avoid reliance on exposed joint sealants and their limited design life.

- **a balcony upstand of minimum 75mm below the underside of the threshold.**

The balcony upstand is measured from the balcony drainage layer to the underside of the projecting sill. Note: the drainage layer may not be the waterproofing layer. For example, with an inverted roof the drainage layer would be the top of the insulation and not the waterproofing layer below. This is because drainage between the insulation and waterproofing layer could become silted resulting in the majority of rainwater flowing over the top of the insulation.

- **a waterproofing layer designed to prevent ponding and associated stagnant water.**

Finished falls should be a minimum 1:80 away from the building to the rainwater outlet(s). Where balconies are designed with falls toward or parallel to the building care must be taken to ensure any blockage of the outlet(s) cannot cause flooding into the building. Waterproofing layers at zero falls will only be accepted if the waterproofing membrane has a third party assessment specifically for that use. The membrane should also be fully protected from direct trafficking, for example by provision of paving slabs or decking, and be UV resistant unless fully protected from daylight. The membrane should be capable of withstanding any point loads from supports to decking or paving.

- **an effective drainage system and suitable overflow**

The drainage arrangement should ensure that if an outlet or downpipe becomes blocked it will not lead to flooding into the

building. This can be achieved by using one outlet and an overflow (not less than the capacity of the outlet) or two outlets connected to independent downpipes. Alternatively, the balcony kerb can be set a minimum 25mm below the level of the door threshold to allow safe spillage in the event of water build up. An outlet chute through perimeter construction into external hoppers can also act as the overflow if it is of an appropriate size to serve both the discharge and overflow capacities.

- **drainage gaps between any decking or paving and at balcony perimeters**

Drainage gaps between individual lengths of decking or between each paving slab should be a minimum of 10mm. A similar continuous drainage gap should be provided between decking or paving and the threshold sill, perimeter walls and kerbs. Spacers and supports to raised decking or paving should not obstruct the flow of rainwater to outlet(s). The position of drainage outlets beneath decking or paving should be clearly identifiable and accessible for maintenance.

- **a minimum 150mm high splash zone above the decking or paving**

The design of the wall for minimum 150mm above decking or paving should ensure that any splashing off the decking or paving does not reach any part of the wall that could be adversely affected by the presence of moisture. This may be achieved by the use of an impervious wall finish/cladding or an extension of the balcony waterproofing layer to form an upstand with cover flashings and cavity trays if required.

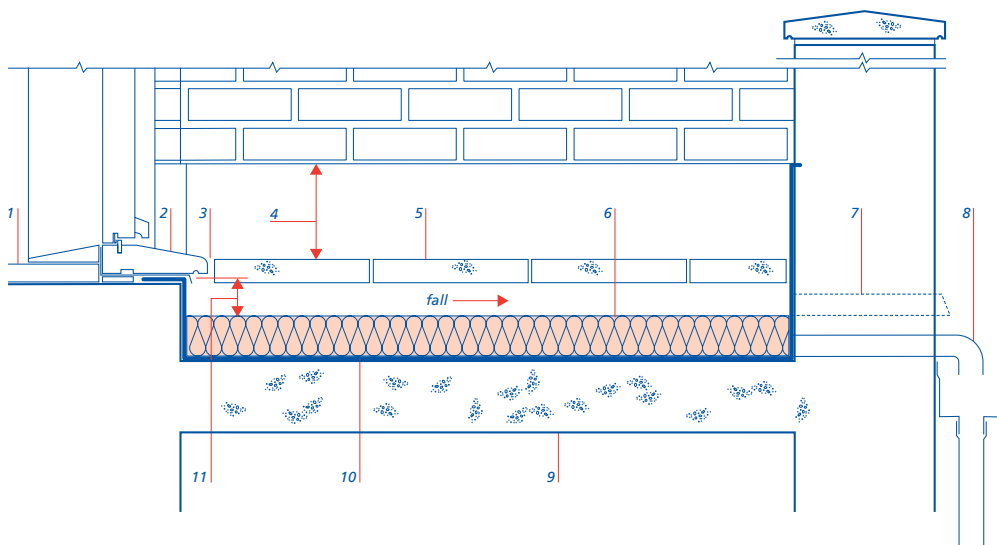
**INVERTED BALCONY**

## Key

- 1 finished floor level
- 2 projecting sill and drip - minimum 45mm overhang
- 3 minimum 10mm gap
- 4 minimum 150mm splash zone (where applicable)
- 5 raised and drained decking or paving on drained supports
- 6 drainage layer is top of insulation
- 7 overflow/warning pipe outlet to be a minimum 25mm below the underside of the door sill
- 8 rainwater outlet and hopper - discharge should avoid passing through accommodation below
- 9 supporting slab
- 10 waterproofing layer with falls to outlet
- 11 minimum 75mm upstand



WARM DECK BALCONY

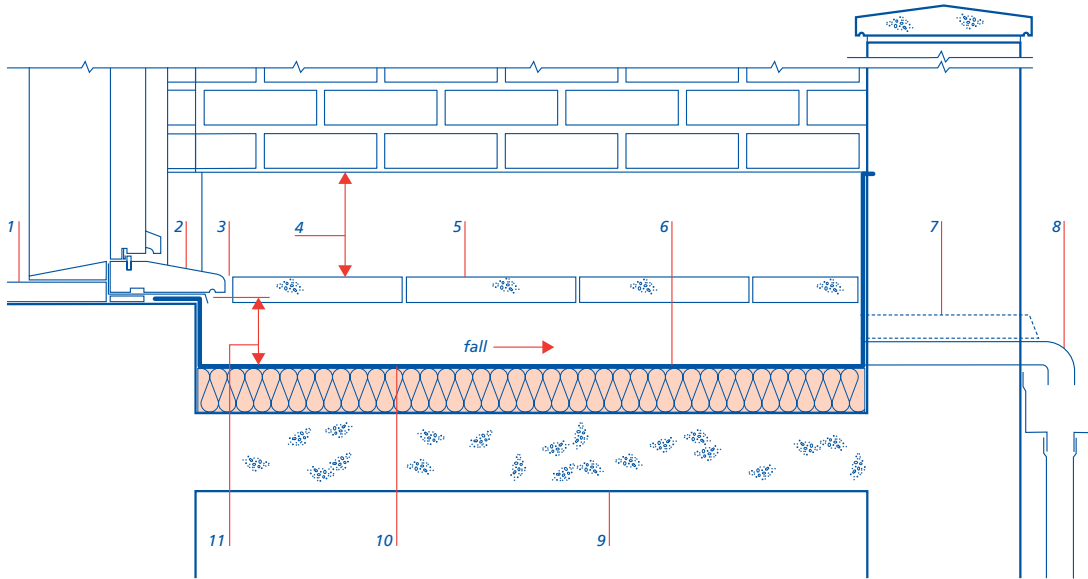

Key

- 1 finished floor level
- 2 projecting sill and drip - minimum 45mm overhang
- 3 minimum 10mm gap
- 4 minimum 150mm splash zone (where applicable)
- 5 raised and drained decking or paving on drained supports
- 6 drainage layer is waterproofing layer
- 7 overflow/warning pipe outlet to be a minimum 25mm below the underside of the door sill
- 8 rainwater outlet and hopper - discharge should avoid passing through accommodation below
- 9 supporting slab
- 10 waterproofing layer with falls to outlet
- 11 minimum 75mm upstand

CANTILEVERED BALCONY

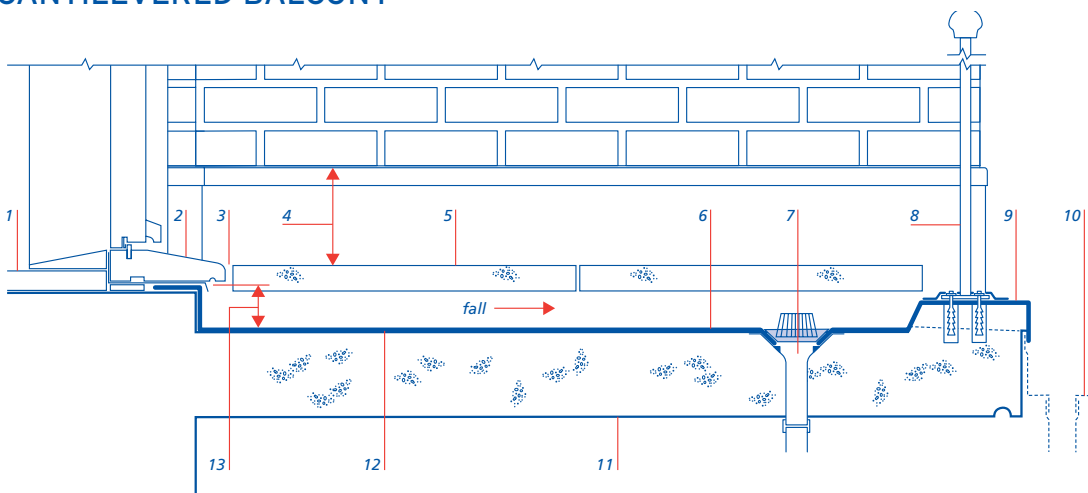

Key

- 1 finished floor level
- 2 projecting sill and drip - minimum 45mm overhang
- 3 minimum 10mm gap
- 4 minimum 150mm splash zone (where applicable)
- 5 raised and drained decking or paving on drained supports
- 6 drainage layer is waterproofing layer
- 7 rainwater outlet
- 8 balustrading
- 9 low kerb - minimum 25mm below the underside of the door sill to act as overflow
- 10 alternative hopper discharge
- 11 supporting slab
- 12 waterproofing layer with falls to outlet
- 13 minimum 75mm upstand

## INDEX

<b>A</b>		<b>I</b>		<b>S</b>	
Access	3, 7	Insulation	2, 3, 6, 7, 9, 11, 12, 13, 14	Screeds	6, 9, 12
Accuracy	4	Inverted roofs	2, 6, 8, 11	Sheet metal decks	4
<b>B</b>		<b>J</b>		Single ply membranes	4, 9, 11, 12, 13
Balconies	1, 2, 3, 4, 5, 7, 17	Joist hangers	1, 5	Sound transmission	2
Balustrading	1, 3, 7	Joists	1, 3, 5, 6, 10	Straps	1, 2, 5
Boarding	5	<b>L</b>		Structural steelwork	1
<b>C</b>		Lateral restraint	2	Strutting	5, 11
Car parking	1	Lead sheet	2, 4	Surface treatments	2, 4, 13
Cold decks	2, 6	Liquid systems	4	<b>T</b>	
Concrete deck	1, 4, 8, 9, 11, 12, 14	Loads	1, 4	Thermal insulation	2, 6
Concrete grade	4	<b>M</b>		Timber	1, 2, 4, 5, 6, 7, 8, 10, 14, 15
<b>D</b>		Mastic asphalt	2, 4, 9, 12, 13, 14	Timber deck	8, 14, 15
Deck	1, 2, 3, 4, 5, 6, 10, 14,	Movement	1, 2, 7	<b>V</b>	
Decking	1, 2, 3, 4, 14	<b>O</b>		Vapour control layers	2, 3, 6, 9, 10, 12, 14, 15
Design	1, 2	Outlets	3, 6	Ventilation	2, 3, 5, 6
Drainage	2, 3, 6	<b>P</b>		<b>W</b>	
Durability	1, 3, 4, 5, 7	Precast concrete construction	1, 4	Warm roofs	2, 8, 9, 10
<b>F</b>		Preservative treatment	1, 3, 11, 13	Waterproofing	2, 4, 5, 6, 9, 10, 11, 17
Falls	2, 3, 6, 12	Profiled metal	1, 2, 4, 8, 10, 12		
Flood prevention	3	Proprietary roofs	4		
Formwork	4	Protection	4, 5, 6, 7, 12		
<b>G</b>		<b>R</b>			
Green roofs	2, 3, 4, 6, 7, 8	Rainwater drainage	2, 3		
Guarding	1, 3, 7	Reinforced bitumen membranes	4, 7, 9, 10, 11, 13, 14		
		Reinforced concrete construction	1		
		Roof gardens	1		

# Chapter 7.2

## Pitched roofs

---



## CONTENTS

	Clause	Page
<b>DESIGN</b>		
Design standards	D1	1
Statutory requirements	D2	1
Loadbearing structure	D3-D4	1
Trussed rafter roofs	D5	1
Traditional cut roofs	D6	2
Timber treatment	D7	3
Weathertightness	D8-D9	3 - 4
Insulation and control of condensation	D10-D11	4
Fire spread	D12-D13	5
Access	D14	5
Roof drainage	D15	6
Provision of information	D16-D17	6
<b>MATERIALS</b>		
Materials standards	M1	6
Structural timber	M2-M3	6
Restraint straps and holding down straps	M4	6
Roofing materials	M5	6
Reclaimed materials	M6	7
<b>SITWORK</b>		
Sitework standards	S1	7
Wall plates	S2	7
Strapping	S3	8
Trussed rafters	S4-S6	8
Traditional cut roofs	S7-S8	9
Water tank supports	S9	10
Fascias, bargeboards and soffits	S10	10
Roofing materials	S11	10
Flashings and weatherings	S12	12
Fire-stopping	S13	14
Thermal insulation	S14	14
Roof drainage	S15	14
<b>APPENDIX 7.2-A</b>		
Roof tile fixings		15
<b>APPENDIX 7.2-B</b>		
Bracing requirements for trussed rafter roofs		16
<b>APPENDIX 7.2-C</b>		
Tank support details		18
<b>APPENDIX 7.2-D</b>		
Sizes and spacing of tile battens		19
<b>APPENDIX 7.2-E</b>		
Strutting for attic trusses and cut roofs that have a floor		19
<b>APPENDIX 7.2-F</b>		
Durability classification of natural slates		19
<b>INDEX</b>		20

## SCOPE

This Chapter gives guidance on meeting the Technical Requirements and recommendations for pitched roofs, including trussed rafter and traditional cut roofs, vertical tiling, weatherproofing and insulation.

## DESIGN STANDARDS

### 7.2 - D1 Design shall meet the Technical Requirements

Design that follows the guidance below will be acceptable for pitched roofs.

## STATUTORY REQUIREMENTS

### 7.2 - D2 Design shall comply with all relevant statutory requirements

Designs should be in accordance with relevant Building Regulations and other statutory requirements.

## LOADBEARING STRUCTURE

### 7.2 - D3 All pitched roof structures shall be designed to support applied loads and self weight without undue movement

Items to be taken into account include:

#### (a) dead and imposed loads

Dead and imposed loads should be calculated in accordance with BS EN 1991-1-1, BS EN 1991-1-3 and BS EN 1991-1-4. Dead loads include the self weight of the roof structure and the roof covering. Imposed loads include snow loadings and the weight of water tanks, insulation, etc.

Structural timber should be specified according to the strength classes in BS EN 338. Timber specifications when using BS 4978 grading rules (eg GS) should be in accordance with BS EN 1912 or strength class specified and also include the timber species.

#### (b) wind loads

Wind loads appropriate to the site location should be calculated in accordance with BS EN 1991-1-4. The roof should be designed to resist wind uplift. This resistance is often provided by the weight of the roof itself but holding down straps should be provided where the self weight of the roof is insufficient.

#### (c) holding down straps

Holding down straps may be required in certain geographical locations and with certain types of roof construction. Some roof covering manufacturers provide detailed guidance.

Where holding down straps are necessary, they should have a minimum cross section of 30mm x 2.5mm and be fixed at maximum 2m centres. Steel straps with a galvanized finish are normally acceptable. The design should detail how straps are to be fixed and what materials are to be used. The durability of fixings should be compatible with the straps.

#### (d) sizing and spacing of members

Sizing and spacing of rafters and ceiling joists should be as:

- clause D5 for trussed rafter roofs
- clause D6 for traditional cut roofs.

Generally, the spacing of rafters and ceiling joists should be not more than 600mm. The spacing of ceiling joists should suit the thickness and size of the plasterboard sheets or other ceiling finish. Plasterboard sheets may be fixed at the following joist centres:

- 9.5mm sheets - up to 450mm spacing
- 12.5mm and 15mm sheets - up to 600mm spacing

Proprietary roof systems should be designed by an Engineer in accordance with Technical Requirement R5.

#### (e) size and spacing of tile battens

The size and spacing of tile battens should be in accordance with the roof covering manufacturer's recommendations, but not less than shown in the table in Appendix 7.2-D.

Nails for fixing battens should be 3.35mm (10 gauge) x 65mm long. Galvanized smooth round nails are acceptable, except where the maximum basic wind speed is over 26m/s (from National Annex Figure NA.1 of BS EN 1991-1-4), where ring shank nails should be specified.

### 7.2 - D4 All pitched roof structures shall be designed so as to transmit loads and give restraint to the supporting structure without undue movement

Items to be taken into account include:

#### (a) wall plates

Normally, trussed rafter roofs and traditional cut roofs should be supported on timber wall plates.

Wall plates should be as detailed in Clause D6(b) with regard to the table concerning minimum sizes. Fixings to connect the roof structure to the wall plate should be specified having regard to the roof construction and the exposure conditions of the site.

For trussed rafter roofs not subject to uplift, the minimum fixing should be two 4.5mm x 100mm long galvanized round wire nails, skew nailed, one from each side of the trussed rafter. Alternatively, truss clips can be used, fixed in accordance with manufacturers' instructions.

In Scotland, nails should be appropriate to wall plate dimensions.

#### (b) holding down straps

In situations where the roof is required to resist uplift, skew nailing is unlikely to provide sufficient strength. Appropriate metal straps should be used.

#### (c) lateral restraint straps

For dwellings of masonry construction, restraint should be provided at rafter level for gable walls. Larger gable or separating walls may also require restraint at ceiling level. See sitework clause S3.

Guidance in assessing when ceiling restraint is needed can be found in Building Regulations.

Lateral restraint straps should have a minimum cross section of 30mm x 5mm and a minimum anchorage downturn of 100mm. The level of galvanizing for straps and their fixings should be in accordance with Tables A.1 and A.2 of BS EN 845-1 (reference should be made to Appendix 6.1-F). Sheradizing is not acceptable in Northern Ireland and the Isle of Man. Straps should be of sufficient length to be fixed to three trusses and should be fixed with solid blocking.

In framed roofs, as an alternative, purlins and pole plates can also provide restraint if the timber abuts a gable construction. Where purlins are used to provide restraint they should not be spaced at more than 2m centres, unless the design shows they are adequate at greater spacing.

In trussed rafter roofs, an alternative is to provide restraint through gable ladder detailing.

#### (d) timber frame construction

For dwellings of timber frame construction, the designer should ensure stability in accordance with BS EN 1995-1-1.

## TRUSSED RAFTER ROOFS

### 7.2 - D5 Trussed rafters shall be designed to support applied loads and self weight without undue movement

Items to be taken into account include:

#### (a) recognised design standards

Trussed rafters should be designed in accordance with BS 5268-3 (or PD 6693-2 when published). Truss manufacturers may have their own computer programs for calculating truss designs in accordance with the British Standard.

#### (b) design information

To ensure that trussed rafters are correctly designed and fabricated, and are suitable for their intended purpose, an accurate specification is necessary.

BS 5268-3 (or PD 6693-2 when published) gives a list of information to be supplied to the truss manufacturer, including the:

- height and location of building with reference to unusual wind conditions
- profile of the trussed rafter, including camber, if required
- span of the trussed rafter
- pitch or pitches of the roof

# 7.2 Pitched roofs

- method of support and position of supports
- type and weights of roof tiles or covering, including sarking, insulation and ceiling materials
- size and approximate position of any water tanks or other equipment to be supported on the trussed rafters
- overhang of rafters at eaves and other eaves details
- positions and dimensions of hatches, chimneys and other openings
- use of the building with reference to any
- unusual environmental conditions
- type of preservative treatment, where required
- spacing of trussed rafters and special timber sizes, where these are required to match existing construction.

The building designer should ensure that the design of the roof as a whole is satisfactory in achieving the overall stability of the complete structure. This includes its connection to, and compatibility with, the supporting structure and adjacent elements of the building.

### (c) bracing

The building designer should specify all bracing. Trussed rafter roofs should be braced in accordance with Table 1 in Appendix 7.2-B, unless the roof is designed and braced in accordance with BS 5268-3 (or PD 6693-2 when published).

All timber bracing to trussed rafters should be at least 100mm x 25mm in section and twice nailed to each trussed rafter and to the wallplate. Nailing should be 3.35mm (10 gauge) x 65mm long galvanized round wire nails.

### (d) spacing

Trussed rafters should not be spaced at centres greater than 600mm. Where this cannot be achieved, eg to accommodate hatch openings or chimneys, the spacing of trussed rafters may be increased as shown below provided that the spacing between centres of trimming trussed rafters does not exceed 2 times the design spacing of trussed rafters and that **b** is smaller than or equal to **2a - c**, where:

**a** = design spacing of trussed rafters

**b** = distance between centres of trimming trussed rafter and adjacent trussed rafter

**c** = nominal width of required opening.

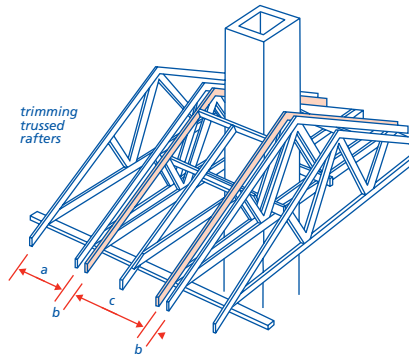

### (e) mono-pitch trusses and girder trusses

Hipped roofs constructed with trussed rafters will generally require a series of diminishing mono-pitched trusses supported by a girder truss.

The bearing of mono-pitched trusses into shoes should be as follows:

Span	Minimum bearing length	Minimum thickness of truss member
Less than 4m	50mm	35mm
4m or more	75mm	35mm

Alternative bearings should be designed by an Engineer in accordance with Technical Requirement R5.

### (f) water tank support

Where water tanks are supported by roof trusses, their load should be transferred to the node points of the trussed rafter and spread over at least three trussed rafters in accordance with BS 5268-3 (or PD 6693-2 when published).

A correct method of water tank support is shown in Appendix 7.2-C.

Proprietary tank support systems should be assessed in accordance with Technical Requirement R3.

### (g) multiple trussed rafters

All multiple and reinforcing timbers to simple or multiple trussed rafters should be designed to be permanently fastened together. The timber members should be either fixed together during manufacture or, alternatively, fully detailed drawings and specifications showing the fixing method should be supplied to the site to enable the components to be assembled correctly.

### (h) roofs incorporating valleys or other special features

Roofs with hips, valleys or other special features should be designed by an Engineer in accordance with Technical Requirement R5. Standard designs supplied by manufacturers which incorporate these features will usually be acceptable.

### (i) combined trussed rafter and cut roofs

Particular care is needed where trussed rafters and a cut roof are combined in a roof design. The designer should provide details of the complete roof. Trussed rafters supporting traditional cut roof members should be designed by an Engineer in accordance with Technical Requirement R5.

### (j) strutting to attic trusses

The part of an attic truss which forms a floor should have strutting in accordance with Appendix 7.2-E.

## TRADITIONAL CUT ROOFS

### 7.2 - D6 Cut roofs shall be designed to support applied loads and self weight without undue movement

Items to be taken into account include:

#### (a) recognised design standards

Sizes of certain roof members for basic pitched roofs are given in TRADA Eurocode 5 span tables (3rd edition) and BS 8103.

Where spans, sizes, spacing or strength classes of timber are outside the scope of authoritative tables or where the form of roof is other than a basic pitched roof, the roof should be designed by an Engineer in accordance with Technical Requirement R5. Calculations should be based on BS EN 1995-1-1 and BS 5268-3 (or PD 6693-2 when published).

#### (b) member sizes

Unless the roof is designed by an Engineer in accordance with Technical Requirement R5, traditionally, nominal sizes of members would be as follows:

Member	Minimum size (mm)
Struts and braces	100 x 50
Wall plates (Scotland)	100 x 25
Wall plates (Northern Ireland & the Isle of Man)	100 x 38
Wall plates (other)	75 x 50
Hips	rafter cut + 25
Valleys	32 thick
Ridges	rafter cut + 25

#### (c) triangulation

In the design of a cut roof, timber members should be triangulated or otherwise arranged to form a coherent structure. All forces inherent in the design should be resolved. The method of fixing or jointing members should be specified.

Particular care should be taken to ensure adequate triangulation when designs incorporate hips and valleys, and when cut roofs are used in conjunction with trussed rafters.

Details of all structural members should be provided.

**(d) strutting to cut roofs**

Any part of a cut roof which forms a floor should have strutting in accordance with Appendix 7.2-E.

**TIMBER TREATMENT**

**7.2 - D7 Measures shall be taken to ensure durability of timber**

Items to be taken into account include:

**(a) treatment against House Longhorn Beetle**

In some areas of the UK, treatment against House Longhorn Beetle is required. Reference should be made to relevant Building Regulations. Reference should also be made to Chapter 2.3 'Timber preservation (natural solid timber)' (Design).

**(b) timber requiring treatment**

The following timber members should be either naturally durable or suitably treated:

- fascias
- bargeboards
- soffits
- tiling battens
- other trim.

These timber members should, where appropriate, also be painted or stained in accordance with the recommendations in Chapter 8.5 'Painting and decorating' (each section).

In pitched roofs with a fully supported weatherproofing membrane, the following timber members should be either naturally durable or suitably treated:

- rafters
- purlins
- ceiling joists
- bracing
- sarking
- wall plates
- battens for fixing vertical cladding
- porch posts.

The level of durability of all the above members can be achieved by natural durability or treatment with preservative. Reference should be made to Chapter 2.3 'Timber preservation (natural solid timber)' (each section) for guidance.

**WEATHERTIGHTNESS**

**7.2 - D8 Roofs shall be designed to satisfactorily resist the passage of rain and snow to the inside of the building**

Items to be taken into account include:

**(a) weathertightness of roof coverings**

Roofs with a tile or slate covering should be designed in accordance with BS 5534 : Parts 1 and 2.

**(b) tiles**

For tiled roofs, the pitch, gauge and lap should be within the limits given in Table 1

of Appendix 7.2-A, unless the manufacturer specifies otherwise.

Fixings for single and double lap tiles should be designed in accordance with BS 5534 and BS EN 1991-1-4. Where tile manufacturers have computer programs based on these British Standards, their recommendations should be followed.

Tables 2 and 3 of Appendix 7.2-A contain minimum fixings for tiles. The tile manufacturer will be able to advise on any additional nails or clips required for a particular location. A fixing schedule produced by the tile manufacturer, based on The Zonal Method, is acceptable.

To avoid the use of small sections of cut tiles, which are difficult to fix, double tiles, tile-and-a-half or half tiles should be used where available from the manufacturer.

**(c) slates**

Natural slates should be fixed in accordance with BS 5534 and BS EN 1991-1-4. Each slate should be nailed twice when centre nailed.

**(d) roof coverings other than tiles or slates**

Lead sheet roofing should be in accordance with BS 6915.

Other types of sheet roofing should be in accordance with the relevant parts of CP 143.

Roofs with the following traditional coverings should be designed in accordance with satisfactory custom and practice:

- natural stone
- shingles
- thatch.

Thatching should be as recommended by the Thatch Advisory Service or other appropriate authority in accordance with Technical Requirement R3.

Proprietary roof coverings including roof lights should be assessed in accordance with Technical Requirement R3.

**(e) roof underlays**

An underlay should be provided for all tiled roofs.

The underlay may be felt to BS EN 13707 or a proprietary sarking membrane complying with Technical Requirement R3. Where the underlay is exposed at eaves level it should be UV resistant or type 5U felt. Alternatively, proprietary eaves guards may be used. A type 1F felt may be used for the remainder of the roof.

To prevent the underlay sagging at the eaves and forming a water trap behind the fascia, the underlay should be supported by a continuous fillet or proprietary eaves support tray.

**(f) rigid sarking**

In areas of severe exposure, a rigid sarking with underlay is recommended and is normal practice in Scotland.

The choice of rigid sarking should take account of the type and fixing of the roof covering. The following materials are acceptable:

- tongued and grooved or square edged boarding to BS 1297
- bitumen impregnated insulating board to BS 1142 : Part 3 (sarking and sheathing grade)
- exterior grade plywood to BS EN 636, service class 3
- type P5 chipboard to BS EN 312
- oriented strand board type OSB3 to BS EN 300
- proprietary products which have been assessed in accordance with Technical Requirement R3.

To avoid damage from condensation, proprietary insulation boards should be used strictly in accordance with the recommendations given in the independent assessment.

**(g) flashings and other weathering details where a pitched roof abuts a vertical surface**

Where a roof abuts a vertical surface, cover flashings, stepped cover flashings, soakers, secret gutters and back or parapet gutters should be provided as necessary. Where the roof is over an enclosed area the wall construction should include cavity trays linked to the flashings. Reference should be made to Sitework clause 7.2 - S12(f) for details.

Cover flashings should be tucked 25mm into a brick joint or chase not less than 75mm above the intersection with the roof.

Flashings and soakers should be of non-ferrous metal and of the same material to avoid electrolytic action.

Where lead is used, soakers should be at least Code 3 and flashings, gutters, saddles, etc should be Code 4 or better.

In the case of gutters behind parapet walls, provision should be made for an overflow in case the outlet becomes blocked.

**(h) weathering details where a pitched roof intersects with a continuous waterproof membrane**

For information on intersections with flat roofs, gutters or valleys, reference should be made to Sitework clause 7.2 - S12(e).

**(i) pipes**

Where soil pipes, vent pipes or other pipes penetrate roof tiling, a lead slate flashing, or a purpose-made accessory supplied by the roof covering manufacturer to form a weathertight joint, should be used.



# 7.2 Pitched roofs

If lead slates are used, they should be supported (e.g. using exterior grade plywood) to prevent the lead sagging.

## (j) chimneys

Flashings should connect with the chimney dpcs. The normal flashing components are shown in Sitework clause 7.2 - S12(g). Components will vary depending on whether the chimney intersects the roof at eaves or ridge level and the type of roof covering. Reference should be made to roof covering manufacturers' information sheets.

For more detailed information on the construction and weatherproofing of chimneys, reference should be made to Chapter 6.8 'Fireplaces, chimneys and flues'.

## (k) ridges and hips

All ridge and hip tiles should be mechanically fixed with self sealing non-ferrous fixings into timber battens. Where proprietary systems are used they should be fixed in accordance with manufacturer's recommendations.

Where ridge and hip tiles are bedded on mortar to rolled tiles, concealed or decorative dentil tiles should be fully bedded into all joints in excess of 25mm thick.

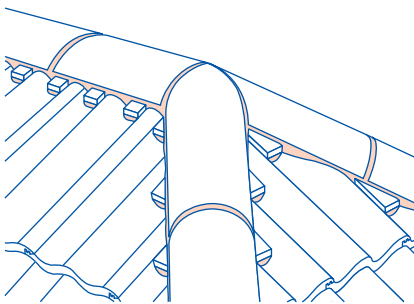

Proprietary dry fixed systems should be assessed in accordance with Technical Requirement R3.

## (l) valleys

Valleys should be formed with purpose-made valley tiles or as an open valley lined with glass reinforced plastic (GRP), lead or other material acceptable under Technical Requirement R3.

Where slates or plain tiles are used, a laced valley, swept valley or mitred tiles with soakers may also be used. Valley tiles should be fixed in accordance with the manufacturer's recommendations and small cut tiles should be avoided.

GRP or other materials should be lapped in accordance with manufacturer's recommendations. Minimum Code 4 lead or other suitable saddle flashing is required at the head of all valleys.

## (m) verges

Where slates or plain tiles are used, the verge should project 38mm to 50mm beyond the gable wall or bargeboard. Interlocking tiles can project 30mm to 60mm.

Unless a proprietary dry verge system or cloaked verge is used, tiles should be bedded into a minimum 100mm wide bed of mortar on an undercloak of cement based board, plain tile or slate which in turn should be bedded onto the gable wall with mortar or suitable bedding sealant. Plain tiles should not be used as an undercloak below 30°pitch or on a bargeboard.

Where verge clips are specified, these should be twice nailed to battens and sized to ensure that they are in direct contact with the top surface of the verge tile.

At verges:

- cut plain tiles are not acceptable and purpose made plain tile and a half should be used
- small sections (less than a half tile width) of cut single-lapped interlocking tiles should not be used
- natural slate verges should be formed with full slates and either slate-and-a-half or half slates that are a minimum 150mm wide
- all tiles and slates should be mechanically fixed at the verge in accordance with Appendix 7.2-A.

## (n) Proprietary roof coverings

Proprietary roof coverings should comply with Technical Requirement R3.

## 7.2 - D9 Vertical tiling and slating shall adequately resist the passage of rain and snow to the inside of the building

Items to be taken into account include:

### (a) moisture barrier

A moisture barrier should be provided behind all vertical tiling and slating.

Moisture barriers should be:

- underfelt or equivalent where the wall structure is brickwork or blockwork. See Design clause 6.1- D14(c)
- a breather membrane where the supporting structure is of timber construction.

For detailed information on the use of moisture barriers in association with timber frame construction, reference should be made to Chapter 6.2 'External timber framed walls'.

### (b) batten size

Batten sizes should comply with Clause D3(e).

## (c) fixing

Every tile or slate should be nailed twice and comply with the general requirements of BS 5534.

## (d) weathering details

Bottom edges should be finished with an under-course tile. At dormer cheeks, the tiles or slates should be specified to be cut close to the slope of the roof, over a flashing fixed to the side of the dormer.

At internal or external angles, purpose made corner tiles or soakers should be used to form a weathertight joint.

Where pitched roofs abut masonry walls, a stepped flashing should be specified, turned behind the tiles. Details are shown in Sitework clause 7.2 - S12.

For information regarding vertical tiling or slating on walls, reference should be made to Chapter 6.1 'External masonry walls' (Design and Sitework) or Chapter 6.2 'External timber framed walls'.

## INSULATION AND CONTROL OF CONDENSATION

### 7.2 - D10 Roofs directly above habitable rooms shall be adequately insulated

The BRE Report 'Thermal insulation: avoiding risks' discusses aspects of insulation relevant to pitched roofs. In England and Wales account should be taken of Accredited Construction Details.

Insulation should be of sufficient thickness to meet the requirements of Building Regulations.

To reduce the risk of freezing, and condensation on pipework, the guidance in Sitework clause 7.2 - S14 should be followed.

### 7.2 - D11 Measures shall be taken to control condensation

Items to be taken into account include:

#### (a) ventilation of main roof spaces

Pitched roofs with insulation at ceiling level should always be ventilated to the outside air to minimise the risk of condensation.

For roofs that incorporate a high water vapour resistance (type HR) underlay (e.g. types 1F/5U felts):

- eaves ventilation should be provided on opposite sides of the roof to permit cross ventilation. Reference should be made to Sitework clause 7.2 -S11(a) for illustrations showing where ventilation should be provided
- where the roof pitch is 15°or more, cross ventilation should be provided to the roof void equivalent to a 10mm slot running the full length of the eaves

- where the ceiling follows the slope of a 'cold roof' regardless of pitch or where a cold roof has a pitch less than 15°, cross ventilation should be provided to the roof void equivalent to a 25mm slot running the full length of the eaves. A nominal 50mm clearance should be maintained between the insulation and the roof underlay
- where the roof pitch exceeds 35° or when the span exceeds 10m, high level ventilation, equivalent to a continuous 5mm opening, should be used in addition to eaves ventilation
- the means of providing cross ventilation to mono-pitched roofs should be in accordance with BS 5250 which indicates eaves ventilation together with the equivalent of a continuous 5mm slot at high level

For unventilated cold roofs that incorporate a low water vapour resistance (type LR) underlay (e.g. a vapour permeable underlay):

- ridge or high level ventilation equivalent to a continuous opening of 5mm should be provided in accordance with BS 5250.

Where vapour permeable underlays are used on sloping roofs, with areas over covered by non-permeable materials (eg flat roofed areas of mansard roofs), ventilation equivalent to a continuous opening of 5mm should be provided at the highest point of each roof slope.

#### (b) position of vapour checks

Vapour control layers should be used in roof constructions where the ceiling board is fixed to the rafters.

In normal pitched roofs where insulation is placed at ceiling level and the void above is ventilated, a vapour control layer is not recommended. Moisture from the dwelling will be diffused through the ceiling and removed by roof space ventilation.

Vapour control layers, where required, should be placed on the warm side of insulation.

#### (c) ventilation of dormers

Pitched dormers should be ventilated from eaves to eaves or, where necessary, from eaves to ridge.

Flat roofed dormers of cold deck construction should be ventilated. The ventilation path should not be blocked by the timber structure, strutting, etc (reference should be made to Chapter 7.1 'Flat roofs and balconies' (Design and Sitework)).

#### (d) methods of ensuring unobstructed ventilation

Ventilation openings where the least dimension exceeds 10mm should be protected to prevent the entry of birds, etc.

Acceptable protection of openings can be provided by using materials complying with Materials clause 7.2 - M5(j).

A spacer in the eaves should be used so that ceiling insulation can be installed over and beyond the wall plate. This minimises the cold bridge without blocking the ventilation. The spacer should be of sufficient length to maintain the ventilation above the insulation.

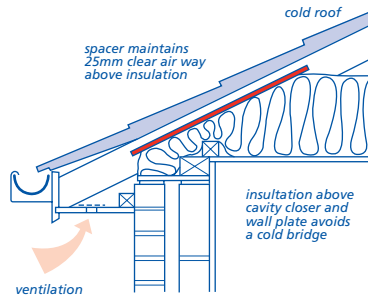

#### (e) other methods of reducing condensation

Methods of reducing condensation, such as draughtstripping loft hatches and sealing holes for services, are given in Sitework clause 7.2 - S14.

## FIRE SPREAD

### 7.2 - D12 Roofs shall adequately resist fire spread

Items to be taken into account include:

#### (a) roof coverings

Slates and concrete or clay tiles are designated AA when tested to BS 476 : Part 3 and therefore can be used without limitation on any pitched roof. The use of some other materials is restricted by statutory requirements, particularly in relation to their distance from site boundaries (reference should be made to Building Regulations). These include:

- bitumen felt slates
- wood shingles
- thatch.

#### (b) chimneys and flue pipes

Combustible material, such as roof timbers and sarking felt, should be kept away from heat sources as described in Chapter 6.8 'Fireplaces, chimneys and flues' (Design).

### 7.2 - D13 Junctions between roofs and compartment or separating walls shall adequately resist fire spread

The junction between a separating or compartment wall and a roof should be firestopped. If there are gaps, fire, smoke and flame can spread from one compartment to the next across the wall.

Mineral wool fire-stopping should be used to allow for movement in the roof timber, and avoid 'hogging' of the roof which is often associated with mortar fire-stopping.

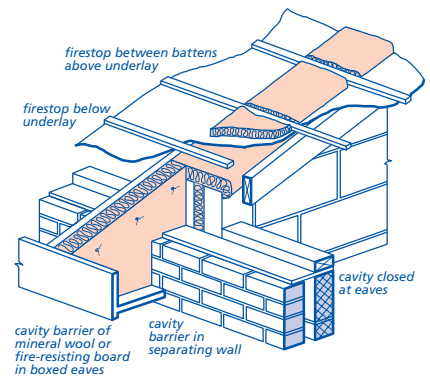

Where a wall separates an integral garage from the rest of a dwelling, other arrangements are possible provided the principle of half-hour fire separation is maintained.

## ACCESS

### 7.2 - D14 Roof voids shall be provided with suitable access

Access should be provided to:

- the main roof space, and
- roof voids that contain cisterns, tanks and the like.

Access is not required to other roof voids containing only water pipes.

#### SIZE OF OPENINGS

Access openings should be not less than 520mm in any direction.

Where equipment (e.g. heating and ventilation equipment) is located in a roof space the size of the opening should permit its removal.

Access openings should not be located directly over stairs or in other hazardous locations.

#### PROVISION OF WALKWAYS

Boarded walkways should be provided:

- between the access opening and any cistern or other permanent equipment located in the roof space, and
- at each cistern or other permanent equipment suitably located for maintenance purposes and at least 1m<sup>2</sup> in area.

Boarding should be securely fixed without compressing the loft insulation.

## ROOF DRAINAGE

**7.2 - D15 Roof drainage shall adequately carry rainwater to an outfall**

Items to be taken into account include:

**(a) provision of gutters and downpipes**

Roofs greater than 6m<sup>2</sup> in area should be provided with rainwater gutters and downpipes. Consideration should also be given to the provision of rainwater drainage to roof areas less than 6m<sup>2</sup>, for example dormer and porch roofs.

Rainwater pipes passing through dwellings should be insulated in accordance with Sitework clause 8.1 - S8(c).

**(b) sizes**

Gutters and downpipes should be of sufficient size to accommodate normal rainfall.

Care is needed in sizing gutters where dormer roofs interrupt the run-off from a pitched roof. The gutter should be sized to cope with the concentrated flows.

**(c) discharge from one roof to another**

Where water from a large roof surface discharges onto another surface, precautions should be taken to prevent erosion of the lower surface.

**(d) discharge into drainage system**

Unless designed otherwise, shoes should be provided to rainwater downpipes.

## PROVISION OF INFORMATION

**7.2 - D16 Designs and specifications shall be produced in a clearly understandable format and include all relevant information**

Full details of trussed rafter roofs should be available on site, including the following:

- layout drawing of trusses and associated items
- bracing requirements
- trimming around chimneys, access hatches, etc
- mono-pitch and lean-to roofs
- girder trusses, multiple trusses and diminishing trusses and how they are fixed together and supported on truss shoes, layboards or similar
- roof intersections (ie hips and valleys).

Assembly drawings are also important where there are complicated roof shapes or where trussed rafter and framed roofs are used in combination.

The drawings should show:

- the number and type of fixings for roof coverings
- means of providing eaves ventilation
- fire-stopping at separating wall and boxed eaves
- flashing details at abutments, chimneys, etc

- supports for water cisterns in the roof space
- restraint strapping
- position, thickness and limits of insulation.

**7.2 - D17 All relevant information shall be distributed to appropriate personnel**

Ensure that design and specification information is issued to site supervisors and relevant specialist subcontractors and/or suppliers.

## MATERIALS STANDARDS

**7.2 - M1 All materials shall:**

**(a) meet the Technical Requirements**

**(b) take account of the design**

Materials that comply with the design and the guidance below will be acceptable for pitched roofs.

Materials for pitched roofs shall comply with all relevant standards, including those listed below. Where no standard exists, Technical Requirement R3 applies (see Chapter 1.1 'Introduction to the Standards and Technical Requirements').

References to British Standards and Codes of Practice include those made under the Construction Products Directive (89/106/EEC) and, in particular, appropriate European Technical Specifications approved by a European Committee for Standardisation (CEN).

## STRUCTURAL TIMBER

**7.2 - M2 Structural timber shall be of the appropriate grades and sizes to support the imposed loads**

Structural timber should be specified according to the strength classes in BS EN 338. Roof members are usually C16, C24 or TR26.

Timber specifications when using the BS 4978 grading rules should be accordance with BS EN 1912 or strength class specified and also include the timber species.

**7.2 - M3 Structural timber shall be of suitable durability**

Structural timber should be pre-treated with preservative where specified by the designer. Chapter 2.3 'Timber preservation (natural solid timber)' (each section) recommends methods of preservative treatment.

Use of reclaimed materials is covered in Clause M6.

## RESTRAINT STRAPS AND HOLDING DOWN STRAPS

**7.2 - M4 Strapping shall be of adequate strength and durability**

Lateral restraint straps should have minimum cross section dimensions of 30mm x 5mm. Vertical holding down straps should have minimum cross section dimensions of 30mm x 2.5mm.

Mild steel straps and fixings should be protected against corrosion in accordance with Tables A.1 and A.2 of BS EN 845-1 (see Appendix 6.1-F). Fixings and straps should be compatible. Sheradizing is not acceptable in Northern Ireland and the Isle of Man.

Straps should be ordered to the correct length and with the correct number of bends and/or twists required by the design.

## ROOFING MATERIALS

**7.2 - M5 Roofing materials shall be of the quality, type and dimensions required by the design**

Items to be taken into account include:

**(a) roof coverings**

The following roof coverings are acceptable:

- clay tiles and fittings to BS EN 1304
- concrete tiles and fittings to BS EN 490 and BS EN 491
- fibre cement slates and fittings to BS EN 492
- natural slates to BS EN 12326 (see Appendix 7.2 - F).
- shingles should be of Western Red Cedar, suitably treated and be Grade 1 to the Canadian Standards Association.

Natural stone should be used in accordance with established custom and practice.

Thatch should be as recommended by the Thatch Advisory Service or other appropriate authority in accordance with Technical Requirement R3.

Use of reclaimed materials is covered in Clause M6.

Proprietary coverings should be assessed in accordance with Technical Requirement R3.

**(b) fixings**

Clout or slate nails for fixing slates and tiles should be one of the following and at least 38mm long:

- aluminium to BS 1202 : Part 3
- copper to BS 1202 : Part 2
- silicon bronze.

Galvanized steel nails are not suitable for fixing slates and tiles because of the risk of damaging the galvanizing but may be used to fix battens and underlay. Nails for fixing battens should be at least 30mm longer

than the batten thickness. Ring shank nails should be used when specified by the designer.

Tile clips should be of aluminium or stainless steel.

#### (c) flashings

The following are acceptable:

- milled lead sheet to BS 1178. Flashings, gutter linings, etc should be at least Code 4, soakers may be Code 3
- aluminium and aluminium alloys to BS 1470 (0.6mm to 0.9mm thick) and protected from contact with mortar by a coating of bituminous paint
- zinc alloy to BS 6561 and 0.6mm thick
- copper to BS 2870, 0.7mm thick is suitable for gutters, 0.55mm thick fully annealed is suitable for flashing, soakers and saddles.

To prevent electrolytic action where metal items may be in contact, eg flashings and soakers, these should not be of different metals.

Proprietary flashings should be assessed in accordance with Technical Requirement R3.

#### (d) underlays

Underlay may be felt to BS EN 13707. Proprietary underlays should be assessed in accordance with Technical Requirement R3. Manufacturers' recommendations should be followed.

Where the underlay is exposed at eaves level it should be UV resistant or type 5U felt. Alternatively, proprietary eaves guards can be used. A type 1F felt may be used for the remainder of the roof.

To minimise the risk of condensation in the case of a fully supported underlay above rigid sarking, underlays should have a low vapour resistance, preferably less than 0.25MNs/g. Underlays with a higher vapour resistance may need increased ventilation to the roof space and between the underlay and sarking. Manufacturers' recommendations should be followed.

#### (e) rigid sarking

The following materials are acceptable:

- tongued and grooved or square edged boarding to BS 1297
- bitumen impregnated insulating board to BS 1142 : Part 3 (sarking and sheathing grade)
- exterior grade plywood to BS EN 636 service class 3
- type P5 chipboard to BS EN 312
- oriented strand board type OSB3 to BS EN 300
- proprietary products which have been assessed in accordance with Technical Requirement R3.

#### (f) battens and counter battens

Battens and counter battens should be to the sizes specified in the design. Timber

used for battens and counter battens should be as listed in BS 5534 and be marked accordingly, (see Appendix 7.2-D).

Battens should be preservative treated unless the timber is naturally durable. Reference should be made to Chapter 2.3 'Timber preservation (natural solid timber)' (Materials) for guidance on the timber types and classes requiring treatment. Cut ends of battens that are in contact with mortar should be treated with a liberal brush coating of preservative.

#### (g) insulation

Thermal insulation should be to the design specification.

The following materials are acceptable:

• mineral fibre mats	to BS EN 13162
• blown mineral fibre	to BS 5803 : Part 2
• blown cellulose fibre	to BS 5803 : Part 3
• proprietary materials assessed in accordance with Technical Requirement R3.	

Insulation of water pipes should be in accordance with Chapter 8.1 'Internal services' (Materials).

#### (h) fascias, bargeboards and soffits

Timber used for fascias, bargeboards, soffits, etc should be pre-treated with preservative. Reference should be made to Chapter 2.3 'Timber preservation (natural solid timber)' (Materials) for guidance on preservative treatments.

The following materials are also acceptable:

- exterior grade plywood to BS EN 636 service class 3
- high density fibre reinforced calcium silicate board that meets the performance requirements of BS 3536
- glass fibre reinforced cement (GRC) board that meets the performance requirements of BS 3536
- proprietary products which have been assessed in accordance with Technical Requirement R3.

#### (i) fire-stopping and cavity barriers

Cavity barriers in boxed eaves should be wire reinforced mineral wool blanket, at least 50mm thick. Ordinary mineral wool quilt is acceptable as fire-stopping above separating walls.

#### (j) protection to ventilation openings

Ventilation openings where the least dimension exceeds 10mm should be protected to prevent the entry of birds, etc.

Acceptable protection of openings can be provided by:

- rigid fabrications with width of opening greater than 3mm and less than 10mm (no restriction on length)

- rigid fabrications with round holes greater than 3mm and less than 10mm in diameter
- square or rectangular mesh where the clear opening size is greater than 3mm and less than 10mm.

#### (k) roof mortar

Roofing mortar should be 1:3 cement:sand with plasticiser. The mix should be based on sharp sand with soft sand added to achieve workability. The proportion of sharp sand should not be less than  $\square$  of the total sand content.

Alternatively, proprietary mortar mixes may be accepted by NHBC if they are shown to have similar strength, durability and workability.

## RECLAIMED MATERIALS

### 7.2 - M6 Reclaimed materials shall be:

#### (a) of the type, size and quality required in the design

#### (b) suitable for re-use

Materials recovered from older buildings, such as timber, slate or tile, may be re-used only with the prior agreement of the NHBC. Independent certification of suitability may be required.

## SITWORK STANDARDS

### 7.2 - S1 All sitework shall:

#### (a) meet the Technical Requirements

#### (b) take account of the design

#### (c) follow established good practice and workmanship

Sitework that complies with the design and the guidance below will be acceptable for pitched roofs.

## WALL PLATES

### 7.2 - S2 Wall plates shall be bedded to distribute roof loads and fixed to prevent wind uplift

Roof construction details should be available on site, particularly for combination and specialist roofs.

Wall plates should be bedded to line and level using nails or straps to hold them down in accordance with the design requirements.

Wall plates should generally be in lengths of not less than 3m but shorter lengths should extend over at least 3 joists/rafters or trusses. Wall plates should be joined using half-lapped joints at corners and in running lengths. In Scotland, where 100mm x 25mm wall plates are used, they should be in long lengths and butt jointed.

Where required, holding down straps should be fixed to the wall plate at maximum 2m centres. If the strap is not turned into a bed joint, it should be fixed to the wall with at least four screw fixings.



# 7.2 Pitched roofs

## STRAPPING

**7.2 - S3 Straps shall be used, where necessary, to restrain gable and separating walls and hold down the roof against wind uplift**

### RESTRAINT STRAPS

Restraint straps, or a restraining form of gable ladder, are required to provide stability to walls. They should be installed as shown in the design and at not more than 2m centres for buildings up to three storeys (two storeys in Scotland). Higher buildings straps should be spaced at not more than 1.25m centres.

Restraint straps should be fixed to solid noggings with a minimum of four fixings of which one should be in the third rafter. The fixings should be four steel screws or four 75mm x 4mm (8 SWG) round nails.

Rafters should not be notched to make the straps flush with the rafter. Straps should go under rafters and over ceiling joists. The turn-down should be on a substantial piece of blockwork, preferably the centre of an uncut block.

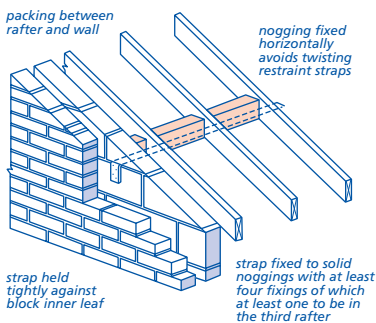

### HOLDING DOWN STRAPS

If the design specifies holding down straps to prevent the roof being lifted off the supporting structure, they should be at 2m centres (maximum).

Where straps are fixed to masonry, hardened nails 4mm in diameter x 75mm long or No 12 wood screws x 50mm long into plugs should be used.

The number of fixings should be in accordance with design requirements and the lowest fixing should be within 150mm of the bottom of the vertical strap.

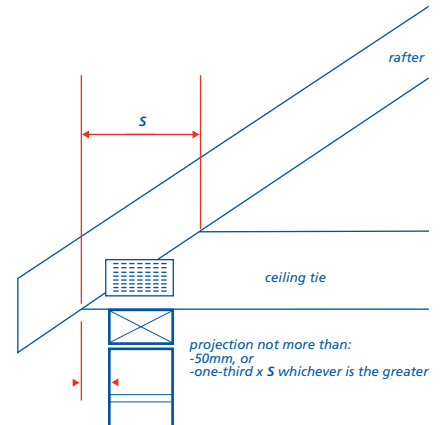
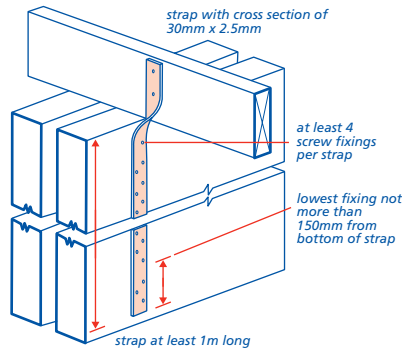

## TRUSSED RAFTERS

**7.2 - S4 Trussed rafters shall be protected from damage before and during construction**

Items to be taken into account include:

### (a) storage

To avoid distortion and prevent damage, trussed rafters should be stored clear of the ground, either flat on level bearers placed under joints (for short term storage) or vertically and propped (for long term storage).

Trusses should be protected against weather to prevent corrosion of truss plates and deterioration of the timber. Ventilation should be provided.

Any damaged trussed rafters or trussed rafters with loose plates should be rejected, not repaired.

### (b) handling

To prevent distortion during construction, trussed rafters should be carried upright (if carried flat, bending can loosen the fasteners).

**7.2 - S5 Trussed rafters shall be erected in accordance with fabricators' instructions**

Detailed guidance on the use and handling of trussed rafters is given in the International Truss Plate Association Technical Handbook available from trussed rafter suppliers.

Detailed drawings should be available on site to show the layout of the trussed rafters, especially at hips, valleys and trimmings to chimneys, etc.

Trussed rafters should be supported only at the junction between the ceiling tie and rafter, unless specifically designed otherwise, e.g. as a cantilever.

Trussed rafters should be evenly spaced and vertical. Temporary bracing should be provided to control the spacing and keep trusses vertical.

Trussed rafters should be fixed to the wall plates either:

- in accordance with the design, or
- using double skew nailing or truss clips.

Avoid damaging the metal truss plates, trussed rafters or wall plates.

The spacing or structure of trusses should not be altered without the designer's approval.

Where the width of gable ladders exceeds that of the trussed rafter centres, noggings should be provided to reduce the span of the roofing tile battens.

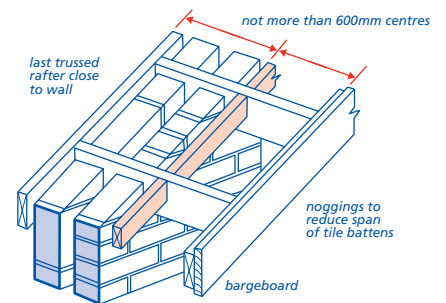

The gable ladder can be used to provide restraint to the external wall if:

- there is blocking between the last trussed rafter and the inner leaf (at a maximum of 2m spacing), and
- the soffit board is cut carefully and then fixed securely so as to restrain the outer leaf.

**7.2 - S6 Trussed rafters shall be braced to prevent distortion**

The roof should be braced using at least 100mm x 25mm timber. All bracing should be twice nailed with 3.35mm (10 gauge) x 65mm long galvanized round wire nails to every trussed rafter it crosses and to the wallplate.

The minimum bracing requirements are shown in Appendix 7.2-B. Additional bracing may be needed in exposed areas. Check the design drawings for special requirements.

All bracing should be completed before starting to lay the roof covering.

Longitudinal binders should butt solidly against the wall at each end. This is most easily achieved by fixing the binder in two lap-jointed lengths.

Braces and binders, where not continuous, should have lapped joints and be nailed to at least two trusses.

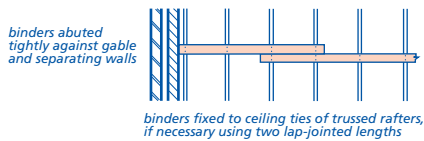

The part of an attic truss which forms a floor should have strutting in accordance with Appendix 7.2-E.

## TRADITIONAL CUT ROOFS

### 7.2 - S7 Roof timbers shall be of the grades and sizes shown on the drawings

Structural timber should be marked to show its strength class (normally C16 or C24). Alternatively, evidence of species and grade should be available to determine the equivalent strength class.

The correct size of timber should be used for each member, as shown on the design drawings.

### 7.2 - S8 Construction of traditional cut roofs shall ensure adequate structural stability

Items to be taken into account include:

#### (a) location of members

All members should be accurately located. Purlins and binders should be built in, where necessary. In a typical traditional roof, the basic timber members are:

- **RAFTER:** carries the weight of the roof finish, eg tiles, tile battens and underfelt
- **CEILING JOIST or TIE:** triangulates the rafters, stopping the walls and roof spreading outwards; supports the ceiling finish and any walkways, etc
- **RIDGE:** provides fixing and spacing for the tops of rafters
- **PURLIN:** supports long span rafters to prevent deflection and increase stiffness
- **STRUTS:** give support to purlins to prevent deflection and transmit roof loading to loadbearing structure below.

The following are extra members which may be used on large roofs:

- **COLLAR:** ties the roof together at purlin level

- **CEILING BINDERS and HANGERS:** support long span ceiling joists
- **POLE PLATES:** similar to purlins but used where ceiling joists are above wall plate level.

Positions of standard structural members are shown in the diagrammatic representation below:

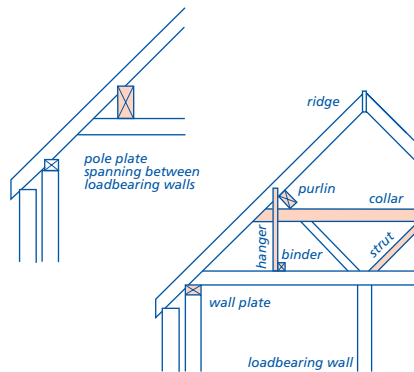

#### (b) prevention of distortion and overloading

The design details for sizes of timber members should be followed.

All framing should be completed before roof coverings are laid.

If a roof is not a simple triangle, all members should be fully supported and tied together. If necessary, temporary support to long span members should be used until the framing is complete.

#### (c) valley and hip construction

Particular care is needed in the construction of valleys and hips:

- **valley rafters** carry load from both sections of the roof. Valley rafters will need to be larger than ordinary rafters to take the extra load and to provide full bearing for the splay cut of jack rafters. (Long valley rafters may need intermediate support.)
- **hip rafters** provide spacing and fixing for jack rafters. They need to be a deeper section than other rafters to take the top cut of the jack rafters. Purlins should be mitred at hips, and lip cut to accept the bottom of the hip rafter.

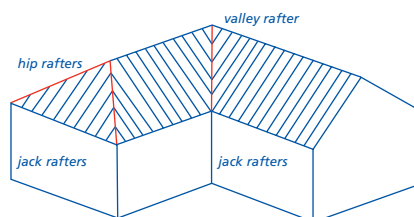

#### (d) dormer construction

On most dormers, the dormer cheek studs should be supported either by a double rafter or by a double floor joist.

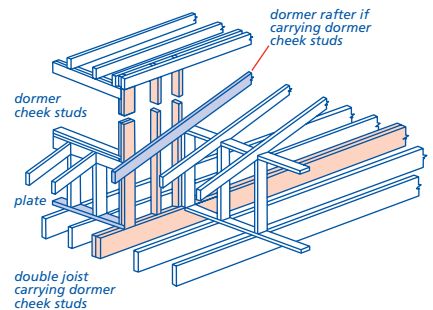

Where cheek framing does not extend to floor level, a double rafter will give necessary support to the cheek. The two rafters must be fixed together.

Trimming members around dormers should be large enough to take the extra load from the cut main roof members and dormer framing and cladding, as detailed in the design.

Dormers should be framed up so they are independent of the window frame, using a suitable lintel over the opening.

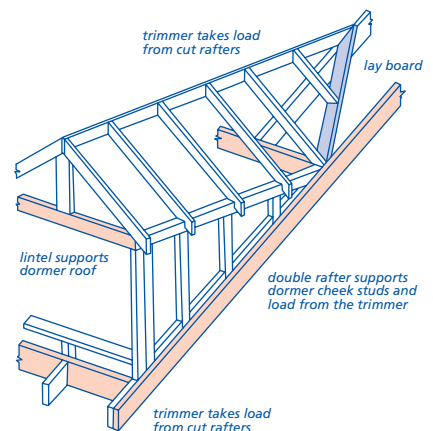

#### (e) jointing of members

All joints should be cut accurately to fit tightly. When they are nailed, care should be taken not to split members.

The following should be used at main connections:

- **RAFTERS** to ceiling joists: nailed lapped joint. The rafter should be birdsmouthed over and skew nailed to the wall plate

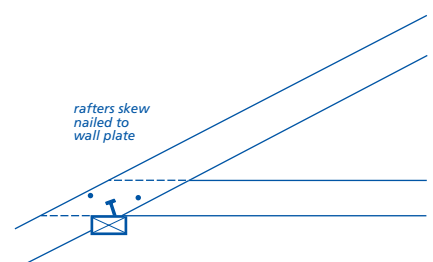

# 7.2 Pitched roofs

- **RAFTERS** to purlin: a birdsmouth joint should be used if the purlin is fixed vertically

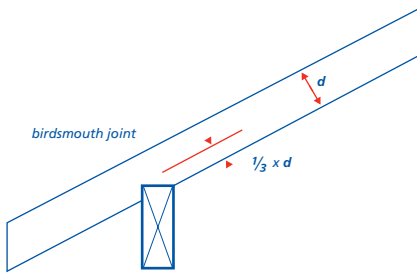

- **PURLIN** connections: support should be provided directly under joint or use a scarf joint. Any scarf joint should be made near a strut so that the joint supports the longer span.

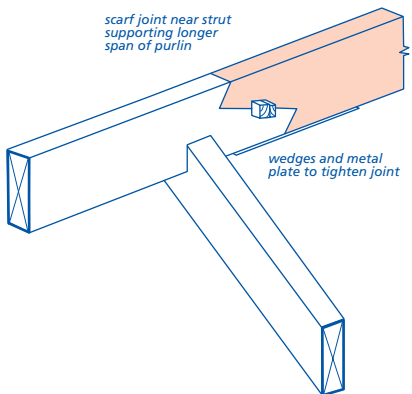
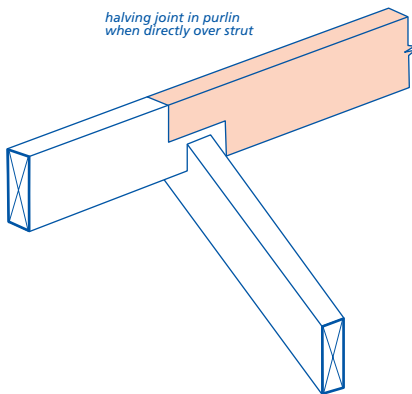

Angle ties should be used on hipped roof corners to prevent the wall plates spreading. For heavily loaded hip rafters, eg where they are carrying purlins, dragon ties or similar bracing should be used to prevent hip rafter spread.

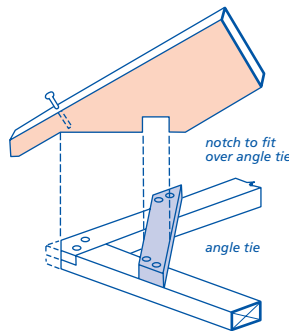
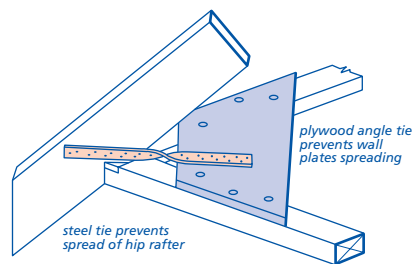
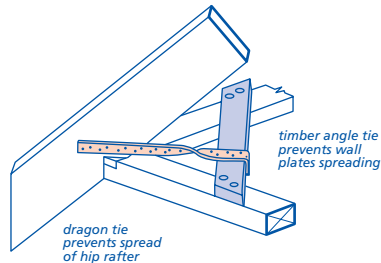

## (f) strutting to cut roofs

Any part of a cut roof which forms a floor should have strutting in accordance with Appendix 7.2-E.

## WATER TANK SUPPORTS

**7.2 - S9 Loads from water cisterns shall be transferred to:**

### (a) the node points of trussed rafters

In trussed rafter roofs, tank stands should be supported at the node points of the trussed rafters and the load spread over at least three trusses.

Correct supports are illustrated in Appendix 7.2-C.

### (b) suitable bearers in traditional cut roofs

In traditional cut roofs, tank stands should be supported as shown in the design.

## FASCIAS, BARGEBOARDS AND SOFFITS

**7.2 - S10 Fascias, bargeboards and soffits shall be selected, fixed and treated against decay in accordance with the design**

Items to be taken into account include:

### (a) timber quality

Timber for external feature work should be free from wane edges, large knots and resinous pockets, splits and other unsightly defects.

### (b) fixing

All joints should be cut and fixed neatly. Mitred angles and splay joints should be used to prevent exposure of end-grain. Butt joints to fascias should be splayed. Fascia boards should have two fixings into each rafter and be fixed at a height that maintains the correct pitch in accordance with the tile manufacturer's recommendations.

### (c) treatment against decay

Where preservative treated timber is cut or planed, a liberal brush coating of preservative should be applied.

All untreated timber that is to be painted should be knotted and primed all round before fixing. When timber requires a stained finish, one coat of stain should be applied before fixing.

## ROOFING MATERIALS

**7.2 - S11 Roofing materials shall be installed in accordance with the design**

Items to be taken into account include:

### (a) ventilation

All roof voids should be ventilated to prevent condensation problems.

Ventilation openings where the least dimension exceeds 10mm should be protected with mesh to prevent entry of birds, etc.

Where proprietary eaves ventilators are used, they should be fixed in accordance with the manufacturer's instructions.

For roofs that incorporate a high water vapour resistance (type HR) underlay ventilation should be provided on opposite sides of the roof space, equivalent to a continuous gap of the width shown in the following drawings:

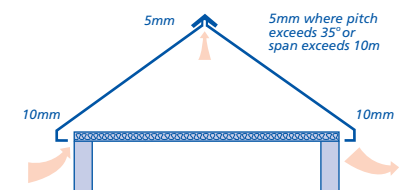

ROOF PITCH OVER 15°



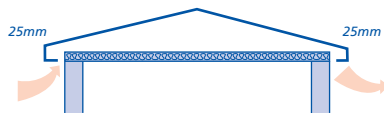

ROOF PITCH BELOW 15°

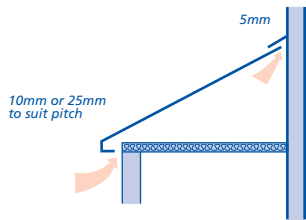

MONO-PITCHED ROOF

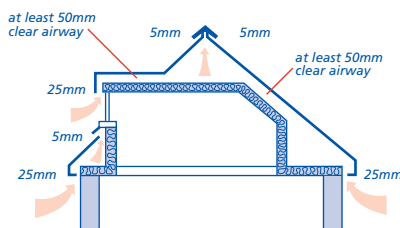

ROOM-IN-ROOF (flat roof dormer)

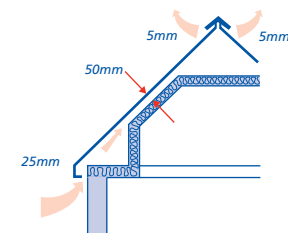

ROOM-IN-ROOF (partially sloping ceiling)

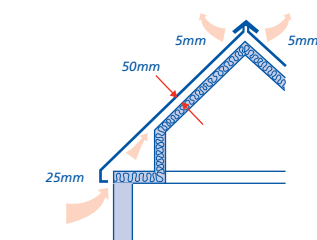

ROOM-IN-ROOF (completely sloping ceiling)

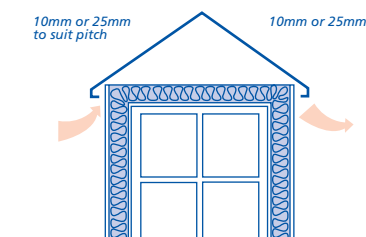

PITCHED ROOF DORMER

For unventilated cold roofs that incorporate a low water vapour resistance (type LR) underlay, (e.g. a vapour permeable underlay) and insulation over a horizontal ceiling, ridge or high level ventilation equivalent to a continuous opening of 5mm should be provided in accordance with the design.

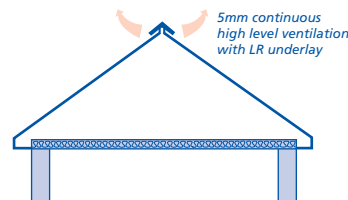

### (b) underlays

Horizontal laps should be as follows:

Pitch	Minimum horizontal lap (underlay not fully supported)
Less than 15°	225mm
15° to 34°	150mm
35° and above	100mm

Vertical laps in the underlay should occur only over rafters and be securely fixed. Horizontal laps should be securely fixed by regular roof battens.

Underlay should be supported at eaves level by a tilting fillet or proprietary eaves support tray. Where the underlay is exposed at eaves level it should be UV resistant or type 5U felt. Alternatively, proprietary eaves guards can be used. A type 1F felt may be used for the remainder of the roof.

Underlay or eaves guards should be dressed into the gutter.

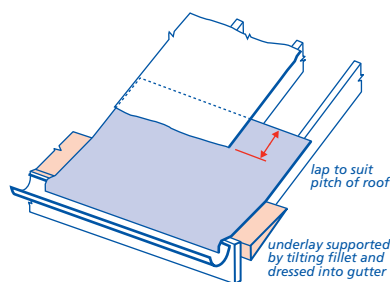

Where traditional mortar pointing is used to bed ridge tiles, the underlay should extend over the ridge. Underlay should continue over hips to form a 150mm minimum lap parallel with the hip rafter.

At valleys, a strip of underlay should be laid under the main roof underlay and held down by the valley battens, where used. The main roof underlay should be cut to the valley batten line.

The underlay should be supported and turned up at least 100mm at all abutments to prevent rain and snow being blown into the roof space.

Particular care is needed where pipes project through the underlay. Torn underlay around pipes can lead to the ceiling becoming wet and stained. To avoid water penetration the underlay should be cut neatly to fit tightly around service penetrations.

### (c) battens and counter battens

Battens should be set out in straight lines, parallel to the ridge and to the gauge required by the tile or slate. The lap should not be decreased because this would reduce weathertightness. The lowest batten should be fixed so that the tile projects not less than 50mm over the gutter.

Battens should be:

- at least 1.2m long
- supported by at least three rafters
- butt jointed on a rafter, and
- nailed to every rafter.

Batten ends should be cut square and nails skew driven on each side of the joint. Where battens are spaced at more than 200mm, not more than one batten in any group of four should be joined over any one truss or rafter. Not more than three joints should be made together in twelve consecutive battens when the gauge is 200mm or less.

Battens on rigid sarking boards should be supported on counter battens to allow free drainage of any water that may reach the underlay. Counter battens should be fixed through to the rafters and not to the sarking boards alone. Battens should be fixed through counter battens to rafters.

Battens should be fixed with cut or wire nails. The nail shank can be smooth, annular ringed or helically threaded. Nails can be steel or aluminium. In coastal areas, steel nails should be hot dip galvanized.

### (d) slates and tiles

Slates should be fully nailed over the whole roof.

The design should specify the number of fixings for clay and concrete tiles. Tables 2 and 3 of Appendix 7.2-A contain minimum fixings for tiles. Additional nails and clips may be necessary in accordance with the design. A fixing schedule produced by the tile manufacturer, based on BS 5534 or The Zonal Method, is acceptable.

Careful setting out will improve the finished appearance of the roof and helps to avoid problems such as unequal overhangs at verges and often makes it possible to avoid excessive tile cutting at abutments, chimneys and similar obstructions. Small sections of cut tiles are

# 7.2 Pitched roofs

difficult to fix and should be avoided. This can be achieved by incorporating tile sizes such as double size tiles, tile and a half or half tiles where these are available.

Single lap interlocking tiles have a tolerance of approximately 3mm in the joint. For double lapped plain tiles and slates, joints should be slightly open. This allows some flexibility in setting out and should avoid tile cutting.

Bottom edges of double lapped slate and plain tile roofs should be finished with an under-eaves course.

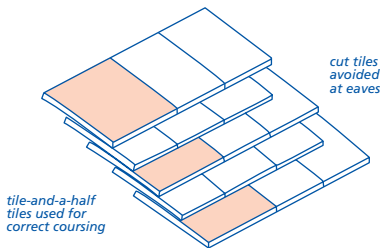

Where verge clips are specified by the manufacturer, these should be twice nailed to the tile batten and be in full contact with the upper tile surface to prevent tile lift.

Tiles to be bedded on mortar should be wetted first on their contact surface. Surface water should be allowed to drain before fixing. Substantial thicknesses of mortar bedding may be needed, eg beneath rolled tiles. To prevent shrinkage of large mortar joints, concealed or decorative dentil tiles should be fully bedded into all joints in excess of 25mm thick.

Proprietary dry fixed systems should be assessed in accordance with Technical Requirement R3.

## (e) roof mortar

Roofing mortar should be 1:3 cement:sand with plasticiser. The mix should be based on sharp sand with soft sand added to achieve workability. The proportion of sharp sand should not be less than  $\frac{1}{3}$  of the total sand content.

Alternatively, proprietary mortar mixes may be accepted by NHBC if they are shown to have similar strength, durability and workability.

Mortar bedding and jointing should be completed in one operation.

## (f) other roof coverings

When using the following materials, the detailing and workmanship should follow the design and recognised good building practice:

- sheet metal roofing including lead, copper and zinc
- thatch
- cedar shingles.

Thatching should be as recommended by the Thatch Advisory Service or other appropriate authority in accordance with Technical Requirement R3.

## FLASHINGS AND WEATHERINGS

### 7.2 - S12 Flashings and weatherings shall be constructed to prevent damp entering the dwelling

Items to be taken into account include:

#### (a) eaves

Tiles should project not less than 50mm across the gutter. For slates or plain tiles, an under-eaves course should be used. Fascia boards should be fixed at a height that maintains the correct pitch in accordance with the tile manufacturer's recommendations.

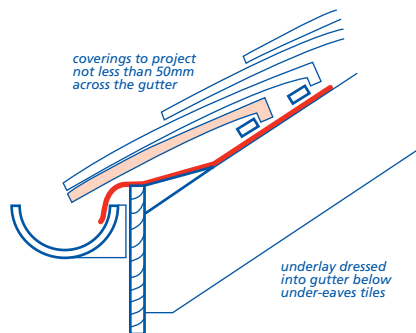

To prevent the underlay sagging at the eaves and forming a water trap behind the fascia, the underlay should be supported by a continuous fillet or proprietary eaves support tray.

#### (b) verges

All verge tiles and slates should be bedded on an undercloak. Alternatively, proprietary dry verge systems should be fixed in accordance with manufacturers' recommendations.

The undercloak should be installed to a true line and bedded on roofing mortar struck off flush with the external surface of the wall. Alternatively, a suitable exterior grade bedding sealant could be used in accordance with manufacturer's recommendations. Where a bargeboard is used, the undercloak should be securely nailed to a true line.

The undercloak should be installed at the correct level to ensure that the line of the tiling is maintained where it passes over the wall.

Where slates or plain tiles are used the verge should project 38mm to 50mm beyond the gable wall or bargeboard. Interlocking tiles can project 30mm to 60mm.

Tile battens should finish 25mm to 50mm from the face of the protecting undercloak.

Cut ends of tile battens that are in contact with mortar should be treated with a liberal brush coating of preservative.

At verges:

- cut plain tiles are not acceptable and purpose made plain tile and a half should be used
- small sections (less than a half tile width) of cut single-lapped interlocking tiles should not be used
- natural slate verges should be formed with full slates and either slate-and-a-half or half slates that are a minimum 150mm wide
- all tiles and slates should be mechanically fixed at the verge in accordance with Appendix 7.2-A.

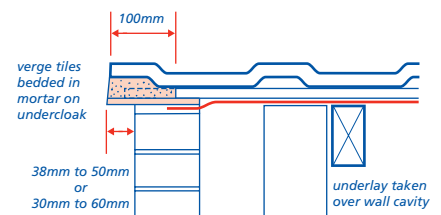

The undercloak should lap the roof underlay but not tilt inwards. Wet bedded verge tiles or slates should be fully bedded on roofing mortar having a minimum width of 100mm. Verge slates or tiles should be bedded on the undercloak and completed in one operation.

Where required by the design interlocking single lap tiles should be secured with clips and twice nailed in position at the tile lap, as well as bedded in mortar. Verge clips should be in full contact with the tile to resist uplift.

#### (c) ridges and hips

Where ridge and hip tiles are bedded on mortar they should be mechanically fixed with self sealing non-ferrous fixings into timber battens. Where proprietary systems are used they should be fixed in accordance with manufacturer's recommendations.

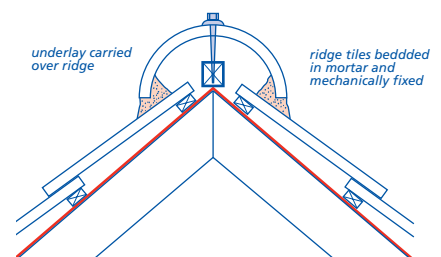

Mortar bedding and pointing should be completed in one operation and achieve a nominal joint thickness of 10mm. To prevent shrinkage of large mortar joints, concealed or decorative dentil tiles should be fully bedded into all joints in excess of 25mm thick. See Design clause D8(k).

Where wet bedded tiles are used at hips, they should be supported at the base of the hip by a galvanized hip iron and project to the centre line of the gutter.

### (d) valleys and hidden gutters

Construction should be adequate in relation to:

- depth
- width
- undercloaking
- pointing
- adequate support
- pitch.

Valleys should be formed using one of the following:

- pre-formed GRP
- valley coursing tiles (plain tiles)
- valley trough tiles (interlocking tiles)
- non-ferrous metal
- a proprietary system.

Where roof coverings are of plain tiles or slates, laced and swept valleys may be used or, alternatively, a mitred valley with soakers. The true pitch of the valley should not be less than the minimum allowed pitch and GRP or other materials should be lapped in accordance with manufacturer's recommendations. Minimum Code 4 lead or other suitable saddle flashing is required at the head of all valleys.

### PROPRIETARY SYSTEMS

Proprietary gutter or valley systems should be securely fixed on to suitable supports and in accordance with the manufacturer's recommendations. Where ply is used for support it should be exterior grade.

Non-ferrous metal saddle flashings or other approved proprietary flashings should be used at intersections and abutments. Lead flashings should be at least Code 4 (colour coded blue).

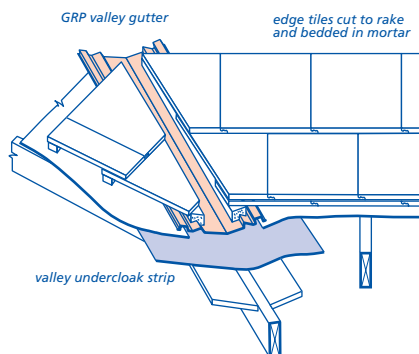

### VALLEY USING VALLEY TILES

In roofs with plain tiles, purpose-made valley coursing tiles should be used. Adjacent roof tiles should be cut neatly to form a smooth junction, preferably cutting from tile-and-a-half tiles.

A laced valley, swept valley or mitred tiles with soakers may also be used. All valley tiles should be fixed in accordance with

the manufacturer's recommendations and small cut tiles should be avoided.

For single lap interlocking tiles, purpose-made valley trough tiles should be supported by gutter boards. Roof tiles should be cut to the correct rake. Mechanical cutting gives a neater appearance than hand cutting. The tiles should be bedded in mortar, leaving a minimum 100mm wide channel (125mm minimum for pitches below 30°).

### LEAD-LINED VALLEY

Lead-lined valleys should be Code 4 (colour coded blue) or Code 5 (colour coded red) and supported on gutter boards of 19mm thick exterior grade ply or as specified. Lead in valleys should be laid in lengths not exceeding 1.5m and be lapped 150mm at each length. Tiles should be cut and bedded as for valley trough tiles except that the mortar should be bedded on an undercloak (for example slate) to prevent direct contact between the lead and the mortar. Mortar should not bridge the welt detail.

### (e) flat roof intersection

Where a flat roof adjoins a pitched roof, or where valleys or gutters occur, the waterproof membrane should be carried up under the tiling to a height of 150mm above the flat roof, valley or gutter and lapped by the roofing underlay.

The lowest course of tiles/slates should not touch the roof membrane.

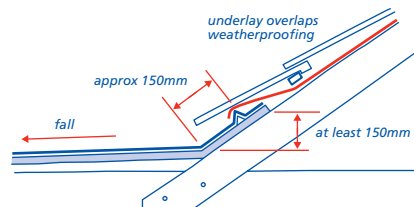

### Note

Where the flat roof is over a dormer, it is recommended that the flat roof should be designed and constructed with a fall to the front or sides.

Flat roofs should comply with Chapter 7.1 'Flat roofs and balconies' (Sitework).

### (f) abutments

All abutments should be weatherproofed using non-ferrous metal flashings. Lead flashings should be at least Code 4 (colour coded blue), while soakers are normally Code 3 (colour coded green). Normally, lead flashings should not exceed 1.5m in length, with laps of not less than 100mm.

Flashing should be tucked into a mortar joint or chase 25mm deep and at least 75mm above the tiling level and lead wedged in place. The joint should then be pointed in cement mortar or using suitable

exterior grade sealant in accordance with the manufacturers recommendations.

Cavity trays should be linked to the flashing to prevent water penetrating into an enclosed area where a:

- flat or pitched roof over an enclosed area abuts a wall
- balcony abuts a wall.

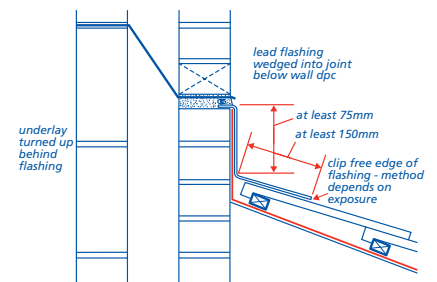

Where a pitched roof abuts the wall at an angle, a stepped cavity tray linked to a stepped flashing should be used. Stepped flashings should be cut from a strip at least 150mm wide. Soakers or a secret gutter should be installed at abutments where slates, flat interlocking tiles or plain tiles are used.

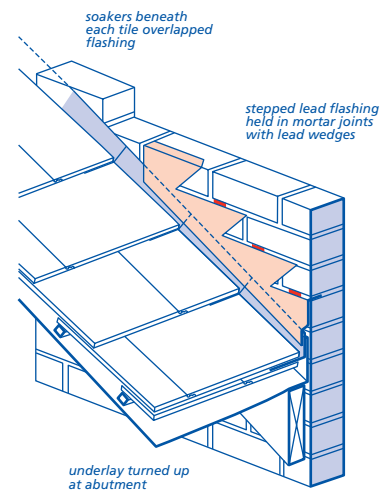

### (g) projections through the roof

A purpose-made one-piece flashing and upstand should be used around pipes projecting through the tiling.

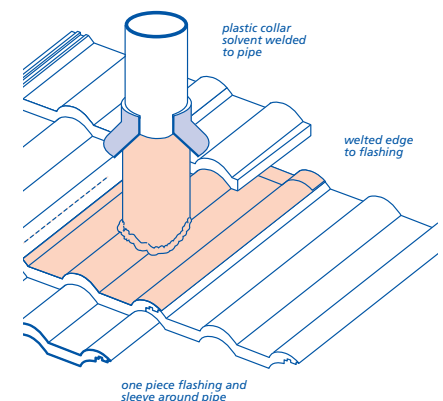

# 7.2 Pitched roofs

Chimney flashings should link with the chimney dpc trays. An example is shown below.

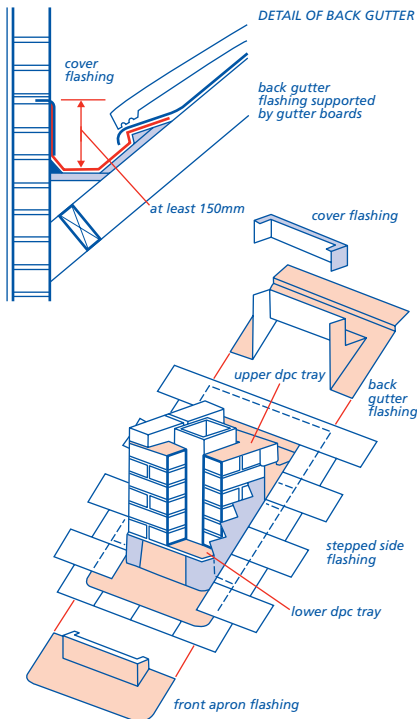

### (h) changes in roof slope

Flashings or soakers should be used where there is a change in roof slope of 5° or more, eg at mansards and sprockets.

A saddle flashing should be used where a ridge meets the main roof.

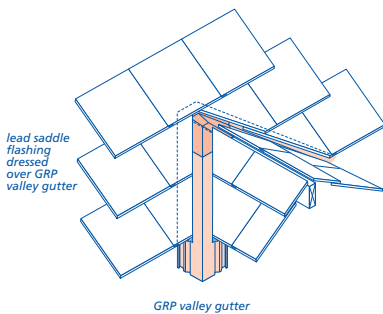

## FIRESTOPPING

### 7.2 - S13 Pitched roofs shall be constructed to offer adequate resistance to the spread of fire

Firestopping and cavity barriers should be provided:

- at junctions between cavities
- above separating walls
- within boxed eaves of separating walls.

The separating wall should stop about 25mm below the top of adjacent roof trusses.

A soft fire-resistant packing, such as mineral wool, should be used to allow for movement in roof timbers and prevent 'hogging' of the tiles.

A cavity barrier should be provided within boxed eaves. The cavity barrier should be wire reinforced mineral wool blanket, at least 50mm thick, nailed to the rafter and carefully cut to shape to fully seal the boxed eaves.

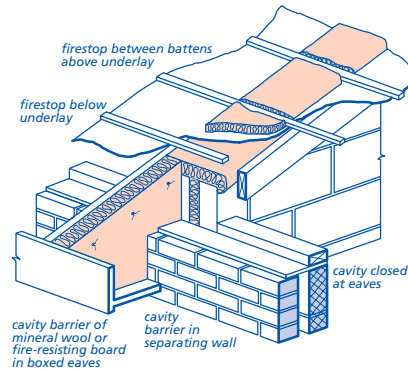

## THERMAL INSULATION

### 7.2 - S14 Thermal insulation and ventilation of roofs shall prevent the adverse effects of condensation

To avoid condensation forming in the roof space ensure that:

- ventilation of the roof is provided in accordance with the design
- insulation does not block any ventilation paths
- insulation is laid over the whole loft area, including the wall plate
- there are no gaps in the insulation.

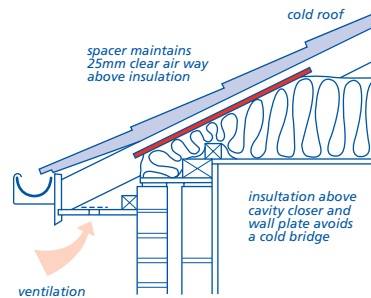

The amount of moist air entering the loft space from the dwelling should be controlled by:

- draughtstripping the loft hatch or using a proprietary loft hatch
- ensuring that the hatch is heavy enough (or suitably fixed) to compress the draught seal
- the use of appropriate downlighters that limit air leakage
- sealing gaps where services pass through the ceiling.

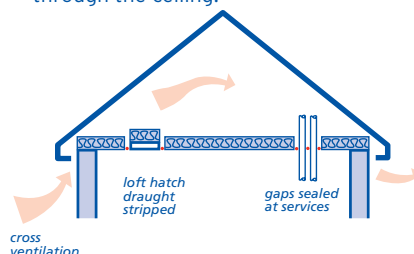

The guidance above will assist in reducing the risk of condensation occurring but is not acceptable as an alternative to cross ventilation of the roof space.

To reduce the risk of freezing and condensation on pipework, the following precautions should be taken:

- place roof insulation above and around water tanks but not below them
- locate water pipes below the main roof insulation whenever possible
- insulate all water services above the main roof insulation, including cisterns and vent pipes.

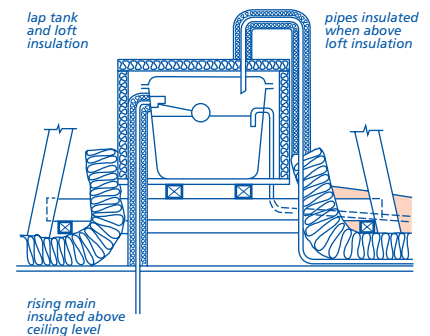

It is recommended that the cold rising main be insulated above ceiling level even if it is below the main roof insulation (condensation that forms on uninsulated cold water pipes located below the main roof insulation can result in damage to ceilings and decorations).

## ROOF DRAINAGE

### 7.2 - S15 Roof drainage shall adequately carry rainwater to an outfall

Items to be taken into account include:

#### (a) fixing and jointing gutters and downpipes

Rainwater gutters and downpipes should be fixed in the positions indicated by the design using the correct type of fittings for internal and external angles, outlets, etc to ensure efficient drainage of the roof. Gutters and downpipes should be supported and jointed in accordance with the manufacturer's recommendations.

Rainwater pipes passing through dwellings should be insulated in accordance with Sitework clause 8.1 - S8(c).

#### (b) falls

Gutters should be laid with sufficient fall towards the outlet, unless designed to be flat, and be provided with stop ends.

#### (c) satisfactory outfall

If a downpipe discharges above ground level or above a drainage gully, a shoe should be fixed to the end of the pipe to prevent walls becoming saturated.

**APPENDIX 7.2-A**

**Roof tile fixings**

**Table 1 - Recommended limits of pitch, gauge and lap for roof tiles**

Type of tile	Gauge	Minimum head-lap (mm)	Minimum permissible pitch(°)
Plain (double-lap)	not more than □ length-lap	65 normally for clay tiles 75 in severe exposure conditions	35 (clay) 35 (plain concrete)
Concrete (single-lap interlocking)	determined by design to comply with manufacturers' recommendations	75 or to manufacturer's specific recommendations	30 (Note: For pitches below 30, evidence shall be provided as to suitable performance)
Slates (double-lap)	not more than □ length-lap	54 <sup>2</sup> minimum, increase with lower pitch and severe exposure conditions	20 subject to head lap

**Notes**

- 1 Clay tiles that do not meet the dimensional and geometric requirements given in BS EN 1304 should be laid at pitches not less than 40°
- 2 For pitches greater than 45° in sheltered and moderate exposure zones only. See BS 5534 table 5 for other pitches and exposures.

**Table 2 - Minimum fixings for single lap interlocking clay and concrete tiles**

Location	Fixings
Verges, abutments and each side of valleys and hips	The end tile in each course should be fixed (nail and/or clip)
Eaves and top edges	Each tile in the first course at the eaves and last course at the ridge/top edge should be fixed (nail and/or clip)
General roof area	For rafter pitches below 45° - tiles should be fixed in accordance with manufacturer's recommendations. For rafter pitches between 45° and 55° - all tiles should be nailed or nailed andclipped. For rafters pitches of 55° and above - all tiles should be nailed and the tail of each tile should be mechanically fixed.

**Notes**

- 1 Additional nails or clips may be required depending on pitch and degree of exposure. Follow the manufacturer's recommendations. A fixing schedule produced by the tile manufacturer, based on The Zonal Method, is acceptable. Evidence of calculations in compliance with Technical Requirements R3 and R5 may be required.
- 2 Nails should be in accordance with BS 5534 and be not less than 3.35mm diameter and should penetrate at least 15mm into battens.

**Table 3 - Minimum fixings for double lap clay and concrete plain tiles**

Location	Fixings
Verges, butments and each side of valleys and hips	The end tile in each course should be twice nailed
Eaves and top edges	Each tile in the first two courses at the eaves and last two courses at the ridge should be twice nailed or otherwise mechanically fixed.
General roof area	<b>Nibbed tiles</b> For rafter pitches below 60° - each tile in every fifth course should be twice nailed. For rafter pitches 60° and above - all tiles should be twice nailed. <b>Nibless tiles</b> All tiles should be twice nailed.

**Notes**



- 1 Additional nails or clips may be required depending on pitch and degree of exposure. Follow the manufacturer's recommendations. A fixing schedule produced by the tile manufacturer, based on The Zonal Method, is acceptable. Evidence of calculations in compliance with Technical Requirements R3 and R5 may be required.
- 2 Nails should be in accordance with BS 5534 and be not less than 2.65mm diameter and should penetrate at least 15mm into battens.



# 7.2 Pitched roofs

## APPENDIX 7.2-B

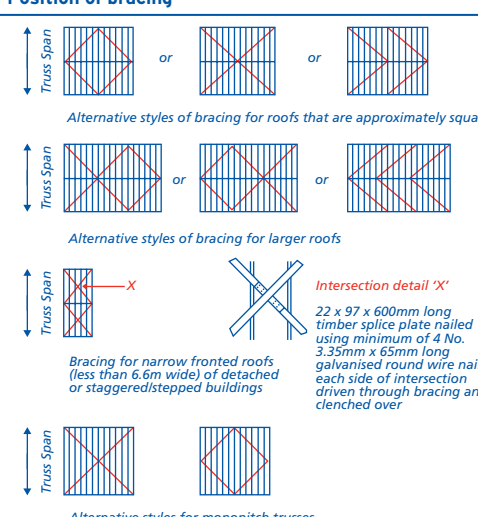
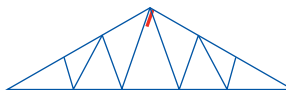
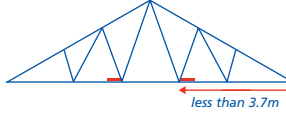
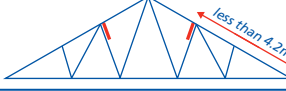
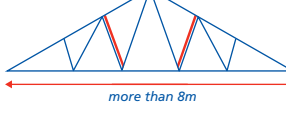
### BRACING REQUIREMENT FOR TRUSSED RAFTER ROOFS

Type of bracing	Position of bracing	Where applicable
A Diagonal rafter bracing (at approx. 45° on plan)	 <p>Alternative styles of bracing for roofs that are approximately square</p> <p>Alternative styles of bracing for larger roofs</p> <p>Bracing for narrow fronted roofs (less than 6.6m wide) of detached or staggered/stepped buildings</p> <p>Intersection detail 'X'</p> <p>22 x 97 x 600mm long timber splice plate nailed using minimum of 4 No. 3.35mm x 65mm long galvanised round wire nails each side of intersection driven through bracing and clenched over</p> <p>Alternative styles for monopitch trusses</p>	All trussed rafter roofs unless rigid sarking such as timber boarding or plywood is used.
B Longitudinal bracing member at ridge node point		All trussed rafter roofs unless rigid sarking such as OSB, timber boarding or plywood is used
C Longitudinal binders at ceiling node points	 <p>less than 3.7m</p>	All ceiling node points, but may be omitted where spacing between braced nodes does not exceed 3.7m
D Longitudinal bracing member at rafter node point	 <p>less than 4.2m</p>	All rafter node points, but may be omitted where spacing between braced nodes does not exceed 4.2m or unless rigid sarking such as OSB, timber boarding or plywood is used
E Chevron bracing between webs	 <p>more than 8m</p>	Where the span exceeds 8m. For monopitch roofs of any span and duopitch roofs over 11m span, bracing should be designed by an Engineer in accordance with Technical Requirement R5.
F Diagonal bracing to end vertical of monopitch trusses		Where not restrained by masonry wall, or cladding in plywood or similar rigid sheet material

### CONDITIONS AND LIMITATIONS ON THE USE OF STANDARD TRUSSED RAFTER BRACING

1 The use of standard bracing does not apply to buildings erected on long stretches of open, level or near level country with no shelter. Examples include flat coastal fringes, fens, airfields and moorland.

The height and location of the building, roof pitch and span are also important. Appendix A of BS : 5268 : Part 3 (AMD.5931) gives full details but as a general guide standard bracing is acceptable for the following situations:

Roof type	Max pitch (°)	No of storeys	Maximum span (m)				
			England & Wales	Scotland		N Ireland & the Isle of Man	
Duo-pitch	35	1	10.6	9.8	(8.6)	9.8	(8.6)
		2	9.1	7.7	(7.2)	7.7	(7.2)
		3	8.5	7.2	(6.0)	7.2	(6.0)
	30	1	12.0	11.6	(10.6)	11.6	(10.6)
		2	11.5	10.0	(8.7)	10.0	(8.7)
		3	10.2	8.8	(7.5)	8.8	(7.5)
Mono-pitch	35	1	5.6	4.9	(4.3)	4.9	(4.3)
		2	4.5	4.2	(3.6)	4.2	(3.6)
		3	4.3	3.6	(3.0)	3.6	(3.0)
	30	1	6.6	5.8	(5.1)	5.8	(5.1)
		2	5.8	5.0	(4.4)	5.0	(4.4)
		3	5.1	4.4	(3.7)	4.4	(3.7)
	25	1	8.1	7.3	(6.5)	7.3	(6.5)
		2	7.2	6.4	(5.6)	6.4	(5.6)
		3	6.4	5.6	(4.5)	5.6	(4.5)

Figures in brackets apply to areas of Scotland either north or west of Ullapool and to areas of Northern Ireland north east of Londonderry.

- 2 The maximum span of the trussed rafters is 12m, the maximum height of the building is 8.4m to the underside of ceiling tie and the maximum rafter spacing is 600mm.
- 3 The maximum length of unsupported masonry between buttressing walls, piers or chimneys is 9m.
- 4 The bracing is for either duo-pitched or mono-pitched roofs.
- 5 The minimum size for bracing members is nominal 25mm x 100mm (3mm tolerance).
- 6 All bracing members to be nailed with 2 No 3.35mm diameter x 65mm long galvanized round nails to every trussed rafter they cross.
- 7 The trusses are supported only at their ends.
- 8 The roof (including hip ends) is rectangular in shape.
- 9 Longitudinal bracing members may be lap-jointed provided the overlap is nailed to at least two trussed rafters. They should extend the full length of the roof and tightly abut gable and party walls. Longitudinal bracing members should permit diagonal bracing to pass.
- 10 At least four diagonal rafter braces are required in every roof. In narrow fronted roofs and mono-pitched roofs, where braces cross, use the intersection detail 'x' above.
- 11 Diagonal rafter bracing should be at approximately 45° to the rafters on plan. Chevron bracing should be at approximately 45° to the web members. Diagonal bracing and chevron bracing should be across all trussed rafters, but small gaps (2 trussed rafters between sets of bracing and 1 trussed rafter adjacent to gable or separating walls) are permitted in the middle of an otherwise fully braced roof.
- 12 Rafter diagonal bracing and longitudinal bracing at rafter level may be omitted where rigid sarking boards are used. Rigid sarking boards (e.g. chipboard, plywood, osb) should be fixed with 3.0mm diameter x 50mm long galvanised round wire nails at 200mm centres to every trussed rafter.
- 13 All trusses should have a ceiling of plasterboard or other suitable material. (For trussed rafters at 600mm centres, 12.5mm plasterboard is required.) Where there is no plasterboard, such as in garages, longitudinal binder bracing (Type C above) is to be used at all ceiling node points and additional diagonal ceiling bracing is required.
- 14 Bracing to satisfy particular conditions shall be in addition to that detailed in the above table.
- 15 The ITPA Technical Handbook gives further details and advice on construction.

7.2



# 7.2 Pitched roofs

## APPENDIX 7.2-C

### Tank support details

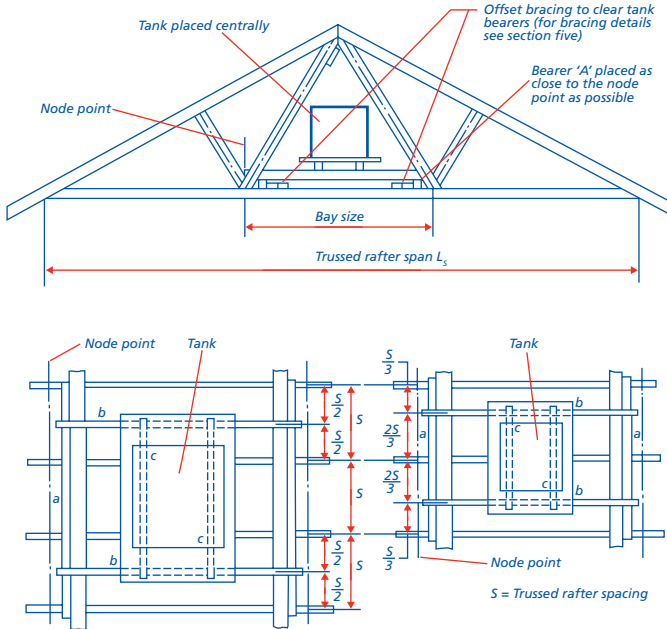

#### Sizes for support members

Total tank capacity to marked waterline	Min. member sizes		Max. trussed rafter span for Fink configuration	Max. bay size for other configurations
	a and c	b		
	mm		m	m
<i>Detail A</i> Not more than 300 L supported on four trussed rafters	47 x 72	2/35 x 97 or		
		1/47 x 120	6.50	2.20
	47 x 72	2/35 x 120 or		
		1/47 x 145	9.00	2.80
<i>Detail B</i> Not more than 230 L supported on three trussed rafters	47 x 72	1/47 x 97	6.50	2.20
	47 x 72	2/35 x 97 or		
		1/47 x 120	9.00	2.80
	47 x 72	2/35 x 120 or		
	1/47 x 145	12.00	3.80	

NOTE: Support members may be of any species with a permissible bending stress not less than that of European redwood/whitewood of GS stress grade (see 14.1).

Reproduced from BS 5268-3 that will be included in PD 6693-2 when published by permission of BSI.

7.2

**APPENDIX 7.2-D**

**Sizes and spacing of tile battens**

The sizes and spacing of tile battens should be specified from the table below.

Batten lengths should be sufficient to span over not less than three consecutive supports.

The actual batten thickness (smaller dimension) should not be less than that given in the table nor more than 3mm oversize. Actual batten width should be within  $\pm 3$ mm of the basic size.

BS 5534 requires delivery notes to accompany the battens and the batten to be marked with the following information - supplier, origin, "graded BS 5534", and size.

	<b>450mm span</b> mm	<b>600mm span</b> mm
<b>Slates</b> (double lap)		
Natural: sized or random	25 x 50	25 x 50
Fibre cement or concrete	25 x 38	25 x 50
<b>Clay and concrete tiles</b>		
Double lap	25 x 38	25 x 38
Single lap	25 x 38	25 x 50

**APPENDIX 7.2-E**

**Strutting for attic trusses and cut roofs that have a floor**

If the distance D exceeds 2.5m between

- the node points which form the width of the floor of the attic truss or
- the supports to a floor within a cut roof,

then additional strutting should be provided as follows;

<b>Distance D</b>	<b>Rows of strutting</b>
Under 2.5	none needed
2.5 to 4.5	1 (at centre of span)
Over 4.5	2 (at equal spacing)

Either herringbone strutting (38mm x 38mm timber) or solid strutting not less than three-quarters the depth of the floor and at least 38mm thick should be used.

**APPENDIX 7.2-F**

**Durability classification of natural slates**

Natural slates should have the characteristics given in the table below:

<b>Characteristics</b>	<b>Code/grade from BS EN 12326</b>
Water Absorption (not more than 0.6%)	A1
Thermal Cycle	T1
Carbonate Content (not more than 20%)	S1

## INDEX

<b>A</b>		<b>H</b>		<b>U</b>	
Abutments	13	Hips	9, 12	Underlay	3, 7, 11
Access	5	Holding down straps	1, 6, 8	<b>V</b>	
<b>B</b>		House Longhorn beetle	3	Valleys	4, 9, 13
Bargeboards	7, 10	<b>I</b>		Vapour checks	5
Battens	1, 4, 7, 11, 19	Imposed loads	1	Ventilation	5, 7, 10
Bracing	2, 8, 16, 19	Insulation	7, 14	Verges	4, 12
<b>C</b>		<b>J</b>		<b>W</b>	
Cavity barriers	7	Jointing	9	Wall plates	1, 7
Chimneys	4, 14	<b>L</b>			
Condensation	4	Lateral restraint straps	1, 6, 8		
Cut roofs	2, 9	<b>M</b>			
<b>D</b>		Moisture barrier	4		
Design	1	<b>P</b>			
Dormers	9	Proprietary roof coverings	4, 13		
Drainage	6, 14	<b>R</b>			
Durability of natural slate	19	Ridges	4, 12		
<b>F</b>		Roof coverings	3, 5, 6		
Fascias	7, 10	Roof mortar	7, 12		
Fire-stopping	5, 7, 14	Roof spaces	4		
Fixing(s)	4, 6, 10, 15	<b>S</b>			
Flashings	3, 7, 12, 13	Sarking, rigid	3, 7		
Flue pipes	5	Slates	3, 11		
<b>G</b>		Soffits	7, 10		
Girder trusses	2	<b>T</b>			
		Tank supports	2, 10, 18		
		Tiles	3, 11, 15		
		Timber	2, 6, 10		
		Trussed rafters	1, 8, 16		

---

# Part 8

## Services and internal finishing

---

- 8.1 Internal services
- 8.2 Wall and ceiling finishes
- 8.3 Floor finishes
- 8.4 Finishings and fitments
- 8.5 Painting and decorating





# Chapter 8.1

## Internal services

---

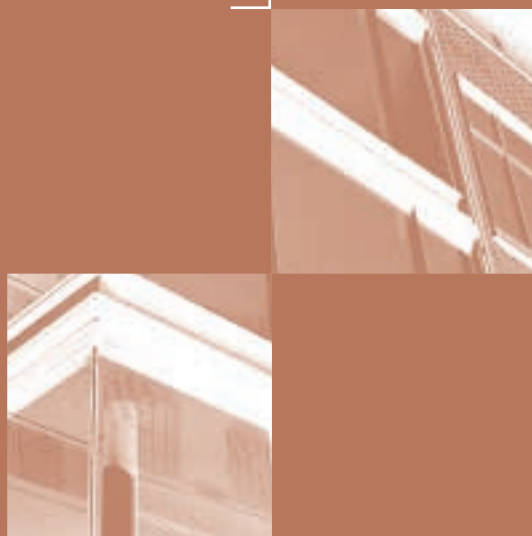

# 8.1 Internal services

## CONTENTS

	Clause	Page
<b>DESIGN</b>		
Design standards	D1	1
Statutory requirements	D2	1
Structural stability	D3	1
Precautions against ground hazards	D4	1
Precautions against chemical attack	D5	1
Water Supply	D6	1
Cold water service	D7	1
Hot water service	D8-D9	1
Electrical service	D10-D11	2
Gas service	D12-D13	3
Space heating	D14-D15	3
Soil and waste systems	D16-D17	3
Provision of information	D18-D19	4
<b>MATERIALS</b>		
Materials standards	M1	4
Precautions against corrosion	M2	4
Materials and appliances	M3	4
<b>SITWORK</b>		
Sitework standards	S1	5
Installation: general	S2	5
Hot and cold water services	S3	6
Electrical service	S4	6
Gas service	S5	7
Meters	S6	7
Space heating	S7	7
Soil and waste systems	S8	7
Testing and commissioning	S9	8
<b>APPENDIX 8.1-A</b>		
Thermal insulation of waterpipes to delay freezing		8
<b>INDEX</b>		8

## SCOPE

This Chapter gives guidance on meeting the Technical Requirements and recommendations for internal services, including plumbing, hot and cold water supply, and gas, electric and solid fuel heating installations.



## DESIGN STANDARDS

### 8.1 - D1 Design shall meet the Technical Requirements

Design that follows the guidance below will be acceptable for internal services.

## STATUTORY REQUIREMENTS

### 8.1 - D2 Design shall comply with all relevant statutory requirements

Designs should be in accordance with relevant Building Regulations and other statutory requirements.

## STRUCTURAL STABILITY

### 8.1 - D3 The design of internal services shall not adversely affect the stability of the dwelling

Notching, drilling and chasing to accommodate service pipes and cables should either:

- comply with Sitework clauses 8.1 - S2(d) and (e), or
- be designed by an Engineer.

## PRECAUTIONS AGAINST GROUND HAZARDS

### 8.1 - D4 Design of service entries shall take account of ground hazards

In certain parts of the country, special precautions are necessary to reduce the entry of radon gas. Areas in England and Wales where special precautions are necessary are detailed in BRE Report 211 'Radon: guidance on protective measures for new dwellings'.

Where landfill and other gases are present precautions are necessary to prevent entry. Details are shown in BRE Report 212 'Construction of new buildings on gas-contaminated land'.

## PRECAUTIONS AGAINST CHEMICAL ATTACK

### 8.1 - D5 Adequate precautions shall be taken to ensure services are not subject to chemical attack

#### WATER SERVICES

Pipes and fittings for water services should be of materials which are resistant to corrosion. The recommendations of the water supplier should be followed as to the compatibility of the water supply with materials and fittings.

#### ELECTRICAL SERVICES

PVC covered cables should not be in contact with polystyrene insulation.

## WATER SUPPLY

### 8.1 - D6 Water service design shall be in accordance with statutory requirements and based on the pressures and flow rates supplied from the incoming main

Water services should be in accordance with relevant Building Regulations and other statutory requirements.

The design of the water service should be based on a minimum dynamic pressure of 1.5 bar at the stopvalve inside the home.

The design should ensure that a minimum flow rate of 20L/min is available at the stopvalve inside the home.

The design should take account of:

- pressure and flow rate reductions where there are long distances between the water main and the stopvalve inside the building. This may involve increasing the diameter of the supply pipe
- pressure fluctuations, or surges, which may occur within the system and the potential damage they may have on fittings. Surge arresters may need to be installed at suitable points within the system.

## COLD WATER SERVICE

### 8.1 - D7 Adequate cold water services shall be provided

Items to be taken into account include:

#### (a) drinking water

Drinking water should be provided at the kitchen sink. The supply should come direct from the supply pipe or, where this is impracticable, from a storage cistern containing an adequate supply of wholesome water. Further information is given in Water Regulations and guides.

#### (b) cold water storage

Cold water storage should be provided:

- to supply an open vented hot water storage system
- where required by the water supplier
- to supply those cold water outlets not connected to the supply pipe.

The cold water storage capacity should take account of the guidance in BS 6700, which recommends:

"In small houses it is usual for storage cisterns supplying only cold water fittings to have a capacity of 100L to 150L, and double this capacity if supplying all water outlets, hot and cold.

In larger houses a total storage capacity of 100L per bedroom is recommended".

Primary feed cisterns for indirect water heating systems should be of adequate capacity.

Cold water storage cisterns should be accessible for inspection and maintenance.

Storage cisterns should have rigid close fitting covers (which are not airtight) and which exclude light and insects.

#### (c) warning and overflow pipes

Warning and overflow pipes should be of adequate size and be provided from all cold water cisterns to a suitable discharge outside of the building. Where permitted by water regulations, the discharge may be internal provided it is conspicuous.

#### (d) reducing the risk of freezing

Pipes and cisterns should be located in the warm envelope of the home to reduce the risk of freezing.

Where pipes and cisterns are placed in unheated spaces, they should be adequately insulated to reduce the risk of freezing (see BS 6700 and Appendix 8.1-A).

## HOT WATER SERVICE

### 8.1 - D8 An adequate hot water service shall be provided in accordance with statutory requirements

Hot water services should be in accordance with relevant Building Regulations and other statutory requirements.

### 8.1 - D9 The hot water services shall be adequate for the likely demand and consumption

Items to be taken into account include:

#### (a) types of system

- instantaneous systems (combination boiler)
 

These systems produce hot water on demand, but generally at significantly lower flow rates than storage systems. They should only be used where the simultaneous demand for hot water is limited e.g. in homes with only one bathroom or shower room, unless the boiler manufacturer can show that the boiler is capable of producing hot water simultaneously to outlets in accordance with clause D9(c).

For storage combination boilers, whose characteristics are similar to storage systems, the storage capacity should meet with the guidance in (b) below.
- storage systems (vented cylinder, unvented hot water storage system, primary store)
 

These systems provide higher flow rates than instantaneous systems but require a suitable space for the siting of the storage vessel.

#### (b) hot water storage

Hot water storage for notional draw-off requirements should be not less than shown in the following table. Where appliances are to be installed requiring greater amounts of hot water, the storage capacity should be increased accordingly:

# 8.1 Internal services

Home with			
Shower only	Bath only	Bath and shower(s*)	Two baths
60L	120L	145L	180L

\*max. 2 showers (excludes instantaneous electric showers)

For systems heated by off-peak electricity, the storage capacity should be in accordance with the recommendations of the electricity supplier.

Where boiler outputs are controlled and can prioritise hot water then storage capacities can be less than the figures in the table. Some storage combination boilers and combined primary storage units (CPSU) have this facility. The manufacturer should be consulted on the appropriate storage capacity for the likely hot water demand.

For homes with a single bathroom/shower room, it is assumed that immediately after filling a bath, some hot water may be required for kitchen or wash basin use, but a second bath will not be required for another 20 or 30 minutes.

For homes with two or more bathrooms, it is assumed that all the installed baths will be filled in succession and that some hot water may be required for kitchen or wash basin use immediately after.

The quantities of hot water stored are based on a water draw off temperature of 60°C.

### (c) flow rates and temperature

The system should be designed and installed so that the following flow rates and temperatures are available:

Outlet	Flow Rate L/s		Supply temperature
	Design Rate (see note 1)	Minimum Rate (see note 2)	
Bath (from storage)	0.3	0.2	60°C
Bath (from combi)	0.2	0.15	40°C
Shower (see note 3)	0.2	0.1	40°C
Wash Basin	0.15	0.1	40°C
Sink	0.2	0.1	60°C

### Notes

- The design flow rate should be available at each outlet when the total demand does not exceed 0.3L/s. When simultaneous discharge occurs, the flow rate at an individual outlet should not be less than the minimum rate.

- The minimum flow rate should normally be available, based on clause D6, but may be less if the pressure and flow rate of the incoming supply falls below 1.5 bar.
- Excludes instantaneous electric showers.
- Further information on flow rates and temperatures can be found in BS 6700.

### (d) unvented hot water storage systems

Unvented hot water storage systems should be assessed in accordance with Technical Requirement R3 or meet the requirements of BS 7206, and be the subject of a third party certification scheme (e.g. Kitemarking).

### (e) safety in showers

Where a shower is installed, adequate provision should be made to ensure that the outlet temperature of the water is not seriously affected by the use of other hot or cold outlets in the dwelling. This may be achieved by the provision of a thermostatic shower mixing valve, appropriate design of pipe sizes or dedicated supplies.

## ELECTRICAL SERVICE

### 8.1 - D10 The electrical installation shall be provided in accordance with relevant regulations

All electrical installations should comply with BS 7671.

Cables which are covered or surrounded by thermal insulation may need to be de-rated. Guidance is available in the BRE report 'Thermal insulation: avoiding risks'.

### 8.1 - D11 An adequate electrical service shall be provided

Items to take into account include:

#### (a) cooking

In all dwellings, a minimum 30A electricity supply, suitably switched and terminated, should be provided to the cooker space.

If a cooker panel is provided it should be located to the side of the cooker space. Where a gas supply is provided to the dwelling, a 13A socket outlet should be positioned at the cooker space.

#### (b) socket outlets

Rooms should be provided with not less than the following 13A outlets. Dual outlets count as two.

Room	Outlets	Notes
Kitchen/utility	8	Where homes have separate areas, the kitchen should have a minimum of 4 outlets, and the utility room 4. Where appliances are provided, at least 3 outlets should be free for general use
Dining room	4	
Living or family room	8	At least 2 outlets should be near the TV aerial outlet
Bedrooms	6 (4)	6 for main bedroom 4 for other bedrooms
Landing	2	
Hall	2	

### (c) lighting

Every room should have at least one fixed lighting outlet.

Lighting outlets should be provided to halls, landings and staircases. At each floor level two-way switching should be provided to staircases.

In common areas to dwellings, artificial lighting should be provided, controlled by either manual switching by persons using the area or automatic light sensitive controls.

### (d) fixed appliances

#### EXTRACT FAN SYSTEMS

Extract fan systems should be designed in accordance with the manufacturer's recommendations. Ducts passing through unheated spaces, such as a roof void, to the outside air should be insulated to prevent condensation affecting the operation of the fan. Alternatively, the ducting should have a means of collecting the condensate and draining it to the outside. Where ducting is part of a mechanical ventilation and heat recovery system it should be insulated in accordance with the manufacturer's recommendations.

#### ELECTRICAL SUPPLY TO GAS APPLIANCES

Where a gas appliance requires an electrical supply, a suitable fixed spur or socket outlet should be provided.

### (e) television

A concealed co-axial cable should be provided from the roof void to a terminal outlet in the main living room. Where the co-axial cable is not provided, a conduit and draw wire or an alternative should be provided. The provision of an aerial is not required.

## GAS SERVICE

### 8.1 - D12 Where provided, gas services shall be adequate and in accordance with relevant standards and codes

All gas services must comply with the Gas Safety (installation and use) Regulations.

British Standards relevant to the design of gas installations include BS 6891 and for Butane and Propane gas, BS 5482. Other authoritative publications such as those prepared by the Institution of Gas Engineers and Managers and Gas Safe Register (GSR) can be used.

Gas pipework to be installed in timber frame construction should allow for the likely differential movement. Reference should be made to Chapter 6.2 'External timber framed walls'.

Where a gas supply is provided, there should be a gas point at the cooker space.

For details of hearths, flues and air supply, refer to Chapter 6.8 'Fireplaces, chimneys and flues'.

### 8.1 - D13 Where provided, gas services shall be adequate

Meters and associated equipment should be located where they are reasonably accessible and not subject to damage. Domestic meters may be of the following type:

- built-in – to the outer leaf of the wall
- surface-mounted – on an external wall
- semi-concealed – sunk into the ground adjacent to the outer wall
- individually purpose-made compartments – in accordance with the recommendations of BS 6400.

## SPACE HEATING

### 8.1 - D14 Where space heating is provided it shall be in accordance with relevant standards

British Standards relevant to heating systems include BS 5449, BS 5410 and BS 8303.

Underfloor heating systems should be designed in accordance with BSRIA guides AG12 and 13.

### 8.1 - D15 Space heating shall be adequate

Items to be taken into account include:

#### (a) minimum standards for living room heating

The main living room of a dwelling should have a heating appliance or a heat output as part of whole home heating which is capable of maintaining a temperature of at least 21°C in the room when the outside temperature is -3°C.

#### (b) minimum standards for whole home heating

The provision of whole home or central heating is discretionary. Where it is provided, it should be designed to recognised standards and based generally on the following:

- external temperature -3°C
- the design temperatures and ventilation rates given in the table below:

Room	Room temperature (°C)	Ventilation rate (air changes per hour)
Living room	21	1.5
Dining room	21	1.5
Bedroom	18	1
Hall and landing	18	1.5
Kitchen	18	2
Bathroom	22	2
Toilet	18	2

#### Notes

- 1 The number of air changes per hour from kitchens and bathrooms should take account of any mechanical ventilation installed.
- 2 Where rooms contain open flued appliances, the rate of air change used for the design should be increased (see BS EN 12828).
- 3 In case of dispute, the design temperatures adopted should be verified by calculations and not by performance tests.

#### (c) safe operation of heating appliances

Reference should be made to Sitework clause 8.1 - S7 and Chapter 6.8 'Fireplaces, chimneys and flues' for guidance on:

- location of appliances
- provision for supply of combustion air and removal of combustion products
- separation from combustible materials.

## SOIL AND WASTE SYSTEMS

### 8.1 - D16 Internal soil and waste systems shall be designed in accordance with relevant statutory requirements

Designs should be in accordance with relevant Building Regulations and other statutory requirements.

### 8.1 - D17 Internal soil and waste systems shall be adequate

Items to be taken into account include:

#### (a) disposal of effluent from the building

Soil and waste systems should comply with any specific requirements from the water supplier.

Guidance and recommendations for building drainage and sanitation are given in BS EN 752 and BS EN 12056.

#### (b) entry of foul air from the drainage system to the building

Soil and waste systems should be arranged so that:

- each branch is adequately ventilated
- foul air from the drainage system cannot enter dwellings.

Ventilation should be provided at the head of underground drains. This may be by a soil pipe or separate ventilation pipe.

Where a soil pipe or ventilation pipe is less than 3m away from an opening into the building, it should extend at least 900mm above that opening.

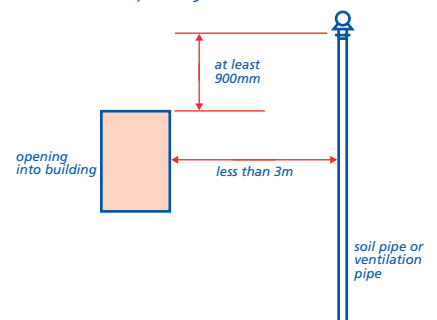

#### (c) air admittance valves

Air admittance valves only allow air to enter the drainage system. Their use does not avoid the need to adequately ventilate the drainage system.

Where air admittance valves are used to terminate soil pipes, they should comply with BS EN 12380 or be assessed in accordance with Technical Requirement R3. Valves within the building should be:

- positioned in areas which are not liable to freezing
- positioned in areas which have adequate ventilation
- accessible for maintenance.

#### (d) entry of vermin

Entry of vermin should be prevented.

#### (e) noise transmission

Precautions should be taken to limit noise transmission from rooms containing WCs, for example:

- soil pipes passing through dwellings should be encased and insulated; the insulation should be continued through the thickness of any sound-insulating floor
- walls between living rooms and rooms containing WCs should be insulated as recommended in Chapter 6.3 'Internal walls' (Design). In England and Wales, reference should be made to statutory requirements.

Sound insulation should be detailed in accordance with Sitework clause 8.1 - S8(c).

## PROVISION OF INFORMATION

**8.1 - D18 Designs and specifications shall be produced in a clearly understandable format and include all relevant information**

For internal services drawings should show:

- location of sanitary fittings
- drainage runs
- location and size of cold water storage cisterns
- location and size of hot water storage cylinder
- hot and cold water pipe runs
- heating boiler and heat emitters
- central heating pipe runs
- gas supply pipe runs
- electrical outlets, switches and consumer unit.

**8.1 - D19 All relevant information shall be distributed to appropriate personnel**

Ensure that design and specification information is issued to site supervisors and relevant specialist subcontractors and/or suppliers.

## MATERIALS STANDARDS

**8.1 - M1 All materials shall:**

- (a) meet the Technical Requirements**
- (b) take account of the design**

Materials that comply with the design and the guidance below will be acceptable for internal services.

Materials for internal services should comply with all relevant standards, including those listed below. Where no standards exist, Technical Requirement R3 applies (see Chapter 1.1 'Introduction to the Standards and Technical Requirements').

References to British Standards and Codes of Practice include those made under the Construction Products Directive (89/106/EEC) and, in particular, appropriate European Technical Specifications approved by a European Committee for Standardisation (CEN).

## PRECAUTIONS AGAINST CORROSION

**8.1 - M2 Materials for internal water services shall be selected to ensure satisfactory service for the life of the systems, taking suitable precautions against corrosion**

Pipes and fittings for water services should be of materials which are safe and minimise the risk of corrosion. The recommendations of the water supplier should be followed as to the compatibility of the water supply with materials and fittings.

In areas where pitting corrosion of copper cylinders occurs, it may be necessary to fit aluminium protector rods. These should be fitted during manufacture in accordance with the relevant British Standard.

The water supplier may require a sacrificial anode to be fitted.

Further guidance is given in BS EN 806.

## MATERIALS AND APPLIANCES

**8.1 - M3 Materials and components shall comply with relevant codes and standards and be approved by relevant authoritative organisations**

Items to be taken into account include:

### (a) water services

Recommendations of the relevant water supplier

- |            |   |
|------------|---|
| BS EN 806  | Specifications for installations inside buildings conveying water for human consumption.  |
| BS 7206    | Specification for unvented hot water storage units and packages.  |
| BS EN 1057 | Copper and copper alloys - seamless round copper for water and gas in sanitary and heating applications.                          |
| BS 1566    | Copper indirect cylinders for domestic purposes.  |
| BS 3198    | Specification for copper hot water storage combination units for domestic purposes.   |
| BS 7291    | Thermoplastics pipes and associated fittings for hot and cold water for domestic purposes and heating installations in buildings. |

### (b) electrical service

Recommendations of the relevant electricity suppliers

- |         |   |
|---------|---|
| BS 7671 | Requirements for electrical installations   |
| BS 6004 | Electric cables. PVC insulated, non-armoured cables for voltages up to and including 450/750V for electric power, lighting and internal wiring. |

### (c) gas service

Recommendations of the relevant gas transporters and suppliers

- |         |   |
|---------|---|
| BS 6400 | Specification for installation of domestic gas meters (2nd family gases)  |
| BS 6891 | Specification for installation of low pressure gas pipework of up to 35mm (R1) in domestic premises (2nd family gases). |

### (d) space heating

- |             |   |
|-------------|---|
| BS 5410     | Code of Practice for oil firing   |
| BS 5449     | Code of Practice for central heating for domestic premises  |
| BS 8303     | Code of Practice for installation of domestic heating and cooking appliances burning solid mineral fuels. |
| BS EN 12828 | Heating systems in buildings - design for water-based heating systems.                                    |

### (e) space heating appliances

Space heating appliances, including all components and controls should be a type approved by the relevant authority, including:

- Solid fuel Solid Fuel Association, Heating Equipment Testing and Approval Scheme
- Electricity British Electrotechnical Approvals Board
- Gas Advantica plc
- Oil OFTEC
- LPG Advantica plc

### (f) soil and waste systems

- |             |   |
|-------------|---|
| BS EN 12056 | Gravity drainage systems inside buildings |
|-------------|---|



## SITWORK STANDARDS

### 8.1 - S1 All sitework shall:

- (a) meet the Technical Requirements
- (b) take account of the design
- (c) follow established good practice and workmanship

Sitework that follows the design and the guidance below will be acceptable for internal services.

## INSTALLATION: GENERAL

### 8.1 - S2 All services shall be installed to ensure satisfactory operation

Items to be taken into account include:

#### (a) location and fitting of pipes and cables

Service entries through the substructure should be constructed as described in Chapter 5.1 'Substructure and ground bearing floors' (Design and Sitework).

Services should:

- where necessary to prevent damage to the service, be sleeved or ducted where passing through structural elements (not solidly embedded)
- not be located in the cavity of an external wall, except for electricity meter tails
- only be buried in screeds where permitted by relevant codes of practice.

Where copper pipes are permitted in floor screeds they should be:

- sleeved or wrapped so that they can move freely along the length and at joints and bends
- jointed with capillary joints.

Where plastic pipework is in or behind wall surfaces, and would otherwise not be located by a metal detector or similar equipment, a metallic tape should be applied to the pipework.

#### (b) jointing of pipes and fittings

Proprietary joints should be made strictly in accordance with the manufacturer's instructions.

Only fluxes recommended by the pipe manufacturer should be used and all traces should be removed immediately after jointing. Fluxes containing lead are not acceptable.

#### (c) fixing of pipes

Pipes should be adequately secured with suitable clips or brackets. Fixings should be installed neatly and spaced to prevent sagging but not restrict thermal movement. Pipes should have adequate falls, where appropriate.

Sufficient room should be allowed for thermal expansion and contraction to avoid damage and noise from pipe movement.

### (d) notching and drilling of joists

#### SOLID TIMBER

Solid timber joists and studs should only be notched and drilled within the limits shown in the table below:

Item	Location	Maximum size
Notching joists up to 250mm depth	top edge 0.1 to 0.2 of span	0.15 x depth of joist
Drilling joists up to 250mm depth	centre line 0.25 to 0.4 of span	0.25 x depth of joist
Drilling studs	centre line 0.25 to 0.4 of height	0.25 x depth of stud

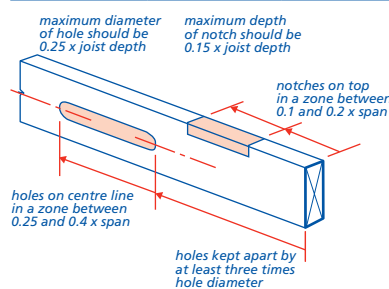

Holes should be kept apart by at least three times hole diameter.

Notches and drillings in the same joist should be at least 100mm apart horizontally.

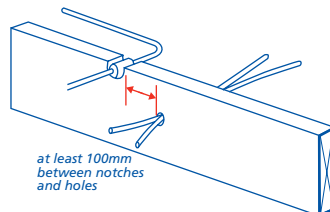

Special instructions should be obtained from the designer when notching and drilling:

- is required in joists deeper than 250mm
- does not meet the above guidelines, or
- is needed close to heavy loads, such as those from partitions, cisterns, cylinders and stair trimming.

If structural strength is impaired by notching or drilling the element should be replaced or correctly repaired.

#### I-JOISTS

In I-joists pre-formed holes are provided in the timber webs for pipes and cables. Other holes and notches should not be cut without the approval of the manufacturer.

#### METAL WEB JOISTS

In metal web joists services should run in the gaps between the metal webs. Where services are in conduits, the conduits may have to be inserted before fixing the joists in position. Reference should also be made to Chapter 6.10 'Light steel framed walls and floors' (Sitework).

### (e) concealed services

Services concealed in walls or floors should be located so that significant cracking of the surface does not occur.

#### WALLS

If chases in walls are necessary, their depth should not exceed:

- one-sixth the thickness of the single leaf for horizontal chases
- one-third the thickness for vertical chases.

Hollow blocks should not be chased unless specifically permitted by the manufacturer.

#### FLOORS

Pipes under floor screeds should, where necessary, be protected by wrapping or ducting. Allowance should be made for thermal expansion, especially at changes of direction.

The cover over a pipe or pipes, or any insulating material should be at least 25mm. Where pipes cross over, the screed thickness should still be not less than 25mm and it may be necessary to form a duct to achieve adequate cover. In an in-situ suspended concrete floor, the location and depth should be approved by the designer.

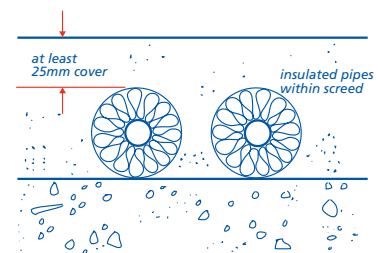

### (f) fire-stopping

Fire-stopping should be provided around any services which penetrate fire-resisting floors, walls or partitions. Where a proprietary system, such as an intumescent seal, is used it should be installed in accordance with the manufacturer's instructions.

### (g) extract ducts

Extract ducts should have sealed joints and be adequately supported. Ducts passing through unheated spaces, such as a roof void, to the outside air should be insulated or a condensation drain should be provided in accordance with the design.

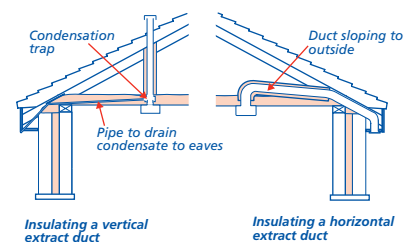

# 8.1 Internal services

## HOT AND COLD WATER SERVICES

**8.1 - S3 Hot and cold water services shall be installed to avoid mechanical, frost and corrosion damage**

Items to be taken into account include:

**(a) protection of the incoming service**

Any stop valve within the curtilage and outside the dwelling should be protected by a shaft or a box.

Service pipes should be at least 750mm below the ground surface. Where this is not possible, adequate precautions should be taken against frost and mechanical damage.

Any underground duct should be sealed at both ends to prevent the entry of fluids, vermin and insects.

**(b) insulation of the incoming service**

If the floor is of suspended construction, the underfloor water service should be insulated as it passes through the ground and the ventilated space.

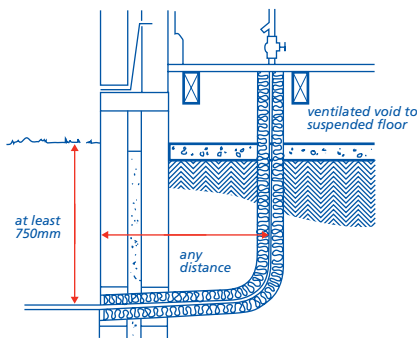

**(c) location of meters**

If a water meter is built into the external wall of the dwelling, it should comply with Clause S6.

**(d) provision of cold water storage**

Cold water storage cisterns should have the capacity specified in the design. Adequate support should be provided for the cistern filled with water.

Water cisterns installed in roof spaces should be supported as described in Chapter 7.2 'Pitched roofs' (Design and Sitework). Continuous support should be provided, where necessary, to prevent the cistern bottom being deformed. Suitable materials for support platforms are:

- softwood boarding
- marine plywood
- chipboard Type P5 to BS EN 312
- Oriented strand board Type OSB3 to BS EN 300 laid with stronger axis (as marked on board) at right angles to the bearers.

All water tanks should be accessible. Gangway boarding should be provided from the roof space access opening to each cistern. An area of 1m<sup>2</sup> of boarding

should be provided next to cisterns to permit routine maintenance. The boarding should be constructed so that ceiling insulation is not compressed.

Water storage cisterns should be protected from contamination by a rigid close fitting cover (which is not airtight) which excludes light and insects.

Holes should be formed with a cutter in the positions shown in the design.

Overflows or warning pipes should be not less than 19mm diameter and situated 25mm from the shut off water level in the cistern. The pipe may dip below the water level in accordance with water regulations. Alternatively, the pipe should terminate vertically downwards or a tee should be fitted horizontally at the discharge end.

**(e) hot water storage**

Hot water cylinders should be fully supported in accordance with manufacturers' recommendations.

Cylinders should be installed vertically, unless designed otherwise, and should be accessible.

Cylinders should be insulated as specified in the design.

Where an immersion heater is fitted, it should be:

- appropriate for the type of water supplied to the dwelling
- thermostatically controlled
- located so that it can be withdrawn for replacement
- fitted with an on/off switch.

**(f) thermal insulation of water services**

All water services in unheated spaces, including cisterns and vent pipes, should be insulated against freezing as specified in the design. Insulation should not be placed beneath a cold water tank where it can benefit from heat from below. Raised tanks should be insulated on all sides in an unheated roof space.

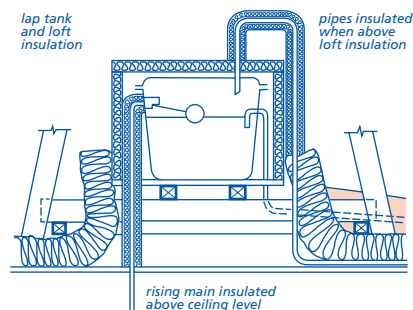

All bends and junctions should be fully insulated, especially near openings to the outside air, such as the eaves, where there is an increased risk of freezing. If possible, water pipes should not be located within the loft space where they could be affected by cold ventilation air.

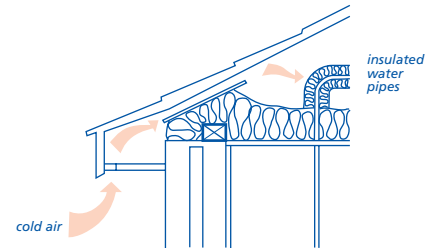

**(g) provision for expansion**

Vented systems should be provided with an expansion pipe.

**(h) unvented hot water systems**

Where an unvented hot water system with a storage capacity greater than 15 litres is required by the design, the assembled system with all its components should have independent third party assessment or meet the requirements of BS 7206 with third party assessment such as Kitemarking. Unvented hot water storage systems should be installed by competent installers.

**(i) draining down facility**

Hot and cold water installations should be capable of being separately drained down.

**(j) use of materials**

Pipes and fittings for water services should be of materials which are safe and minimise the risk of corrosion. The recommendations of the water supplier as to the compatibility of the water supply with materials and fittings should be followed.

In areas where pitting corrosion of copper cylinders occurs, it may be necessary to fit aluminium protector rods. These should be fitted during manufacture in accordance with the relevant British Standard.

## ELECTRICAL SERVICE

**8.1 - S4 Electrical services shall be installed to comply with relevant codes and standards and ensure safe and satisfactory operation**

Items to be taken into account include:

**(a) compliance with Standards**

Electrical installations should comply with BS 7671 'Requirements for electrical installations'.

**(b) manufacturers' recommendations**

Any work involving material or equipment installed as part of the supply or use of electricity should be carried out in accordance with manufacturers' recommendations.

### (c) location of electric cables

Cables without special protection, such as an earthed metal conduit, should be positioned as follows:

- vertically from the outlet or switch being served, or
- horizontally from the outlet or switch being served, or
- within the shaded zone in the diagram below, or
- not less than 50mm from the surface of a wall, or
- not less than 50mm from the top or bottom of a timber joist or batten in a floor or ceiling.

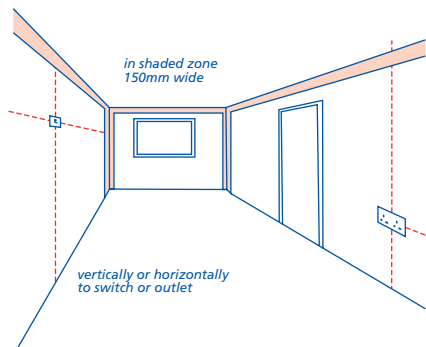

LOCATION OF CABLES WITHOUT SPECIAL PROTECTION

Where the position of switches or sockets can be determined from the reverse side of the wall or partition, the zone on one side of the wall or partition also extends to the reverse side.

### (d) location of cables in relation to insulation

Cables should not be placed under, against or within thermal insulation, unless they have been appropriately sized. For further guidance, refer to the BRE Report 'Thermal insulation: avoiding risks'.

PVC covered cables should not be in contact with polystyrene insulation.

### (e) location of socket outlets and switches

Socket outlets and switches on walls should be located in accordance with relevant Building Regulations.

## GAS SERVICE

### 8.1 - S5 Where a gas service is installed, it shall comply with relevant codes and standards to ensure safe and satisfactory operation

Items to be taken into account include:

#### (a) compliance with Standards

Service pipework up to and including the emergency control valve and meter should be in accordance with the requirements of the gas transporter, gas supplier and primary meter owner. Installation pipework and appliances should meet with relevant standards and codes including those published by Institution of Gas Engineers

and Managers (IGEM) or Gas Safe Register (GSR).

Gas pipework to be installed in timber frame construction should allow for likely differential movement. Reference should be made to Chapter 6.2 'External timber framed walls'.

## METERS

### 8.1 - S6 Openings in walls for meter cabinets shall be structurally adequate and prevent dampness entering the dwelling

#### EXTERNAL ELECTRICITY AND GAS METERS

Openings for electricity and gas meter cabinets set into external walls should be provided with dpcs and cavity trays.

Except for purpose-designed built-in meter boxes provided by gas and electricity companies lintels are required.

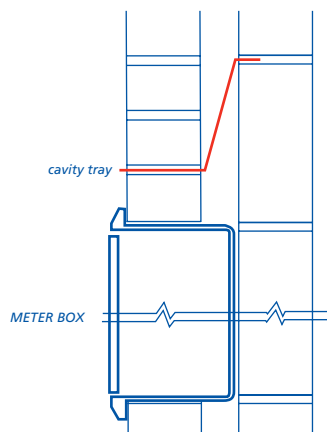

## SPACE HEATING

### 8.1 - S7 Installation of space heating systems shall comply with relevant codes and standards and ensure safe and satisfactory operation

Items to be taken into account include:

(a) location and fitting of appliances  
Reference should be made to Chapter 6.8 'Fireplaces, chimneys and flues'.

#### (b) location of warm air ducts

Warm air ducts for gas-fired air heaters should be installed in accordance with the design, and follow the manufacturer's recommendations.

#### (c) thermal insulation of heating services

All pipework and ductwork should be insulated as specified in the design.

#### (d) underfloor heating systems

Detailed guidance on underfloor heating systems is given in BSRIA guides AG12 and 13. Drawings should be made available on site showing the pipe routes.

## SOIL AND WASTE SYSTEMS

### 8.1 - S8 Soil and waste systems shall be installed to ensure that effluent is removed without affecting health or creating unnecessary noise and smell

Items to be taken into account include:

#### (a) pipework

Soil and waste pipes should be fixed neatly and securely to provide correct falls.

#### (b) sanitary fittings

Fixings to walls and floors should be appropriate for the weight of fittings. Excess packing should be avoided under sanitary fittings.

All sanitary fittings, cisterns, basin brackets and the like should be fixed with non-ferrous or stainless steel screws or fixings.

#### (c) sound insulation of pipes

Insulation should be provided to all soil pipes passing through dwellings.

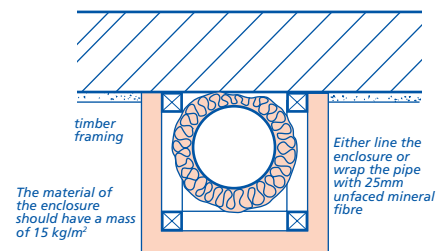

#### (d) flexible joints/sealants

Junctions with wall tiling around baths and showers on joisted floors should be made with watertight flexible sealant to accommodate movement. The manufacturer's instructions should be followed.

#### (e) accessories

All specified accessories, such as chains, plugs, etc should be provided and installed. WC lids and seats should be stable when open.

#### (f) waste disposal units

Waste disposal units should have adequate provision for support and should be fitted with a tubular trap (not bottle or re-sealing) and be connected to the drainage system in accordance with the manufacturer's instructions.

#### (g) air admittance valves (AAVs)

AAVs should only be used where specified in the design. They should not be positioned in areas which are liable to freezing.

AAVs require a free movement of air around them which can be achieved by ventilation grilles, discreet gaps around the boxing or ventilation of the boxing into a ventilated roof void. The ventilation area should be not less than 2500mm<sup>2</sup> unless otherwise specified by the manufacturer.



## TESTING AND COMMISSIONING

### 8.1 - S9 All services shall be tested

Testing should be carried out in accordance with all relevant regulations and codes of practice.

Pipes to be located under screeds should be air or water tested both before and after the screed is laid.

Leaks or other defects should be made good prior to the application of finishes.

Before completion and handover of the building services should be commissioned in accordance with relevant regulations and codes of practice.

## APPENDIX 8.1-A

### Thermal insulation of water pipes to delay freezing

Minimum insulation thickness (mm) needed to delay freezing inside domestic premises for cold water systems.				
Outside pipe diameter (mm)	Thermal conductivity of material at 0°C W/(m·K)			
	0.025	0.030	0.035	0.040
15	30	45	70	91
22-28	12	15	19	24

Notes:  
The conditions assumed for the table are:

- air temperature -6°C
- water temperature +7°C
- ice formation 50%

Examples of insulating materials	
Thermal conductivity W/(m·K)	Material
Less than 0.020	Rigid phenolic foam
0.020 to 0.025	Polyisocyanurate form and rigid polyurethane foam
0.025 to 0.030	PVC foam
0.030 to 0.035	Expanded polystyrene, extruded polystyrene, cross-linked polyethylene foam, expanded nitrile rubber and improved polyethylene foam
0.035 to 0.040	Standard polyethylene foam, expanded synthetic rubber and cellular glass

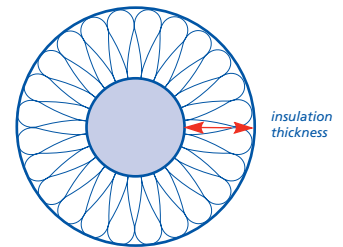

See table above for minimum thickness of insulation

## INDEX

### A

Accessories	7
Air admittance valves	3, 7
Appliances	2, 4, 7

### C

Cables, location	5, 7
Cold water services	1, 6
Cold water storage	1, 6
Concealed services	5
Cooking	2
Corrosion	4

### D

Draining down	6
Drilling timber	5
Drinking water	1

### E

Effluent, disposal	3
Electrical services	2, 4, 6
Expansion	6
Extract ducts	5
Extract fans	2

### F

Fire-stopping	5
Flow rates	2
Freezing	1, 8

### G

Gas service	3, 4, 7
Ground hazards	1

### H

Hot water services	1, 6
Hot water storage	1, 6

### I

Insulation, thermal	6, 7, 8
---------------------	---------

### J

Jointing	5
Joints and sealant	7

### L

Lighting	2
----------	---

### M

Materials, use of	6
Meters	6, 7

### N

Noise transmission	3
Notching timber	5

### O

Overflow pipes	1
----------------	---

### P

Pipes, fixing	5
Pipes, location	5

### R

Room temperatures	3
-------------------	---

### S

Sanitary fittings	7
Services, protection	6
Showers, safety	2
Socket outlets	2, 7
Soil and waste systems	3, 4, 7
Soil system ventilation	3
Sound insulation of pipes	7
Space heating	3, 4, 7
Switches, location	7

### T

Television outlet	2
Testing	8

### U

Underfloor heating	7
Unvented hot water storage	2, 6

### V

Vermin	3
--------	---

### W

Warm air ducts	7
Warning pipes	1
Waste disposal units	7
Water services, supply	1, 4

# Chapter 8.2

## Wall and ceiling finishes

---



# 8.2 Wall and ceiling finishes

## CONTENTS

	Clause	Page
<b>DESIGN</b>		
Design standards	D1	1
Statutory requirements	D2	1
Plastering	D3	1
Plasterboard and dry lining	D4	1
Ceramic wall tiling	D5	2
Provision of information	D6-D7	2
<b>MATERIALS</b>		
Materials standards	M1	2
Plastering	M2	2
Plasterboard and dry lining	M3	2
Ceramic wall tiling	M4	2
<b>SITWORK</b>		
Sitework standards	S1	3
Plastering	S2	3
Plasterboard and dry lining	S3	3
Ceramic wall tiling	S4	4
<b>APPENDIX 8.2-A</b>		
Dry lining to receive ceramic wall tiling		5
<b>INDEX</b>		5

## SCOPE

This Chapter gives guidance on meeting the Technical Requirements and recommendations for internal wall and ceiling finishes.

## DESIGN STANDARDS

### 8.2 - D1 Design shall meet the Technical Requirements

Design that follows the guidance below will be acceptable for wall and ceiling finishes.

Where a fixed shower or showerhead fixing is provided over a bath at a height that will permit persons to stand under, a screen or other suitable means of containing the water should be provided.

Surfaces which will be subjected to water from the use of a showerhead over a bath should be tiled or have an appropriate alternative water resistant finish.

## STATUTORY REQUIREMENTS

### 8.2 - D2 Design shall comply with all relevant statutory requirements

Designs should be in accordance with relevant Building Regulations and other statutory requirements.

## PLASTERING

### 8.2 - D3 Design shall ensure a suitable substrate for the intended decorative finish

Items to be taken into account include:

#### (a) background

Backgrounds should be given appropriate treatment before plastering in accordance with BS 5492 Code of Practice for internal plastering.

#### HIGH DENSITY CLAY OR CONCRETE BRICKS AND BLOCKS AND DENSE CONCRETE (including floor soffits)

- suitable bonding treatment
- hacking
- spatterdash
- stipple.

#### MIXED BACKGROUNDS, eg CONCRETE WITH BRICKS/BLOCKS

- may require expanded metal, to provide key for plastering and to reduce the effects of differential movement.

#### LIGHTWEIGHT CONCRETE BLOCKS

- plaster should not be stronger than recommended by the blockwork manufacturer.

#### AUTOCLAVED AERATED CONCRETE BLOCKS

- plastering should be carried out in accordance with manufacturers' recommendations, with special care taken regarding the moisture condition of the blocks.

#### NORMAL CLAY BRICKWORK, CONCRETE BLOCK

- may require raked joints or the use of keyed bricks.

### PLASTERBOARD

- reference should be made to BS 5492 for plastering on plasterboard.

#### (b) services

Services to be concealed by plaster should be tested, where possible, before plastering is commenced (reference should be made to Chapter 8.1 'Internal services' (Sitework)).

#### (c) plaster mix

Plaster mixes should be specified as appropriate for the:

- strength and surface characteristics of the background
- intended quality of the plaster surface
- application of further finishes.

Undercoats, finishing coats and mix proportions should be as recommended by the plaster manufacturer for the particular conditions of use. Portland cement and gypsum plaster should not be used in the same mix.

#### (d) plaster thickness

#### DECORATIVE FINISH

The number of plaster coats should be sufficient to achieve a reasonably plane finish in accordance with the following:

Surface to be plastered	Min no of coats	Thickness of plaster
<b>Walls</b>		
Metal lathing	3	13mm (nominal from lathing)
Brickwork	2	up to 13mm
Blockwork	2	up to 13mm
Plasterboard or concrete	1	sufficient to provide a crack-free surface
<b>Ceilings</b>		
Concrete	2	10mm (maximum)
Plasterboard	1	skimcoat

#### FIRE RESISTANCE AND SOUND INSULATION

Where plaster is intended to contribute to fire resistance or sound insulation, minimum requirements for plaster thickness are specified in the appropriate statutory regulations.

#### (e) plastic compound finish

Plastic compound finishes containing asbestos should not be specified.

## PLASTERBOARD AND DRY LINING

### 8.2 - D4 Dry lining shall be designed to be suitable for the intended decorative finish

Dry lining work should be in accordance with BS 8212.

Items to be taken into account include:

#### (a) support of plasterboard

Supports for plasterboard should be designed so that the following span limits are not exceeded:

Board thickness (mm)	Timber support centres (mm)	Intermediate noggings required	Perimeter noggings required
9.5	400	No	Yes
	450	Yes	Yes
12.5	400	No	Yes
	450	No	Yes
	600	Yes	Yes
15	600	No	No

#### Notes

1. Cut edges should only be used at perimeters. In all other situations cut edges should finish over a support or noggling.
2. Additional intermediate noggings may be required where fire resistance is necessary.

Plasterboard to receive ceramic wall tiling should be supported in accordance with the details given in Appendix 8.2-A.

Where double layers of plasterboard are used, for example for improved sound insulation, board joints should be staggered from one layer to the other and extra noggings provided to support the second layer.

#### (b) surface facing

Plasterboard should be fixed face side out for both plastering and direct decoration finishes.

Tapered edge boards should be used for surfaces to be decorated directly on the board surface.

#### (c) fire resistance

Where plasterboard contributes to fire resistance, its thickness and treatment should be as specified in the appropriate statutory regulations.

#### (d) vapour control layers

Where required to control interstitial condensation, vapour control layers should be incorporated. In timber frame walls, vapour control layers should be in accordance with recommendations detailed in Chapter 6.2 'External timber framed walls' (Design).

In roof constructions, vapour control layers should be in accordance with the following chapters:

7.1 'Flat roofs and balconies' (Design)

7.2 'Pitched roofs' (Design).

#### (e) fixings

#### PLASTERBOARD

Plasterboard may be fixed to:

- timber, using plasterboard nails or dry wall screws
- metal, using dry wall screws.

# 8.2 Wall and ceiling finishes

## DRY LINING

Dry lining may be fixed by:

- adhesive dabs
- nailing or screwing to timber battens
- screwing to metal channels
- proprietary fixing systems.

Where insulated dry lining is fixed with adhesive dabs, nailable plugs should also be specified in accordance with manufacturers' recommendations.

### (f) gap sealing

Gap sealing should be specified, where necessary, to prevent draughts (see Sitework clause 8.2 - S3(f) for details).

### (g) coving

Location, type, size and method of fixing should be specified.

## CERAMIC WALL TILING

**8.2 - D5 Ceramic wall tiling shall be designed and specified to achieve a surface of acceptable appearance and adequate durability**

Items to be taken into account include:

### (a) background

#### EVENNESS

Background surfaces for tiling should be sufficiently even to achieve a plane tiled surface.

#### STRENGTH

Background surfaces should be strong enough to support tiling of the specified thickness.

#### BOND

The background should provide adequate mechanical key. Very smooth and dense surfaces may require bonding agents for increased adhesion.

#### UNIFORMITY

Surfaces should be sufficiently uniform to avoid differential movement. Metal lathing or wire netting may be necessary to cover junctions.

#### SUCTION

Background surfaces should have adequate porosity for the specified method of fixing the tiles. Where cement mortar is to be used as an adhesive, a background containing soluble salts may require special precautions, such as the use of mortar with sulfate-resisting cement.

### (b) tile quality

Tiles should be appropriate for their location and intended use. Specification items may include:

- surface finish
- size and thickness
- colour
- edge shape
- fittings (coves, skirtings, etc)
- accessories (soap tray, paper holder, hooks, etc).

The weight of tiles on lightweight plasters should not exceed 20kg/m<sup>2</sup> (e.g. not be thicker than 8mm).

### (c) fixing

Tiles should be fixed as appropriate for the background, using:

- cement mortar, or
- proprietary adhesive.

Tiles likely to be frequently wetted should be fixed using solid bed fixing method with a water resistant adhesive on a moisture-resistant background.

### (d) joint filling

Grouting should be:

- cement-based epoxy resin or a proprietary product
- waterproof in and around shower enclosures where tiling can be saturated.

A sealing method should be specified for the joint between sanitary fittings and adjacent tiling - this is particularly important where movement can take place, eg where timber floors are used.

## PROVISION OF INFORMATION

**8.2 - D6 Designs and specifications shall be produced in a clearly understandable format and include all relevant information**

Design information should include:

- schedule of finishes
- plaster thickness, mix and special requirements
- location of vapour checks behind dry lining
- extent and detail of tiled surfaces
- location of services adjacent to tiled surfaces.

**8.2 - D7 All relevant information shall be distributed to appropriate personnel**

Ensure that design and specification information is issued to site supervisors and relevant specialist subcontractors and/or suppliers.

## MATERIALS STANDARDS

**8.2 - M1 All materials shall:**

- (a) meet the Technical Requirements**
- (b) take account of the design**

Materials that comply with the design and the guidance below will be acceptable for wall and ceiling finishes.

Materials for wall and ceiling finishes should comply with all relevant standards, including those listed below. Where no standard exists, Technical Requirement R3 applies (see Chapter 1.1 'Introduction to the Standards and Technical Requirements').

References to British Standards and Codes of Practice include those made under the

Construction Products Directive (89/106/EEC) and, in particular, appropriate European Technical Specifications approved by a European Committee for Standardisation (CEN).

## PLASTERING

**8.2 - M2 Materials for plastering shall be adequate for the location and intended use**

Items to be taken into account include:

### (a) plasters

Relevant standards include:

- BS EN 13279 Gypsum binders and gypsum plasters.
- BS 5270 Part 1 Specification for polyvinyl acetate (PVAC) emulsion bonding agents for indoor use with gypsum building plasters.

### (b) materials for render

Relevant standards include:

- BS EN 197 Specification for Portland cements
- BS EN 13139 Aggregates for mortar.

### (c) metal laths and beads

Relevant standards include:

- BS 405 Specification for uncoated expanded metal carbon steel sheets for general purposes
- BS EN 13658 Metal lath and beads. Parts 1 and 2 Definitions, requirements and test methods.

## PLASTERBOARD AND DRY LINING

**8.2 - M3 Materials for plasterboard and dry lining shall be adequate for the location and intended use**

Relevant standards include:

- BS 1230 Gypsum plasterboard

Recommendations regarding materials for use in dry lining work are included in:

- BS 8212 Code of Practice for dry lining and partitioning using gypsum plasterboard.

## CERAMIC WALL TILING

**8.2 - M4 Materials for ceramic tiling shall be adequate for the location and intended use**

Relevant standards include:

- BS EN 14411 Ceramic tiles. Definitions, classification, characteristics and marking.
- BS EN 12004 Adhesives for tiles. Definitions and specifications.
- BS EN 13888 Grouts for tiles. Definitions and specifications.

## SITWORK STANDARDS

**8.2 - S1 All sitework shall:**  
**(a) meet the Technical Requirements**  
**(b) take account of the design**  
**(c) follow established good practice and workmanship**

Sitework that complies with the design and the guidance below will be acceptable for wall and ceiling finishes.

## PLASTERING

**8.2 - S2 Plastering shall be suitable for the intended decorative finish**

Items to be taken into account include:

**(a) background**

### EVENNESS

Background to be plastered should be sufficiently even to provide a reasonably plane plaster finish and to avoid the necessity for excessive dubbing out before the finish is applied.

### BOND

The background should provide a satisfactory key. Backgrounds may be improved by:

- raking out masonry joints
- hacking and scratching
- applying a spatterdash coat or stipple coat
- applying a bonding agent.

### SUCTION

Suction of the background should be checked for adequacy and should be reasonably even. Where different materials in the background could cause cracks, eg in floors of precast beams and infill blocks, metal lathing should be used or other precautions taken.

### EDGE PROTECTION

Metal beads should be fixed to provide edge protection, where necessary, using zinc-plated fasteners as recommended by the manufacturer.

**(b) services**

All services to be concealed behind plaster should be completed and protected against any adverse effects of chemical action or thermal movement. Where there appears to be a risk of insufficient plaster cover to avoid surface cracking, fix metal lathing or wire netting.

**(c) plaster mix**

Plaster should be mixed in the specified proportions or as recommended by the plaster manufacturer for the particular location and use.

Undercoats and finishing coats should be compatible. Portland cement and gypsum plaster should not be used in the same mix.

**(d) plaster thickness**

### DECORATIVE FINISH

Plaster should be applied to a thickness, excluding any dubbing out, sufficient to achieve the required quality of finish, in accordance with the following:

Surface to be plastered	Min no of coats	Thickness of plaster
<b>Walls</b>		
Metal lathing	3	13mm (nominal from lathing)
Brickwork	2	up to 13mm
Blockwork	2	up to 13mm
Plasterboard or concrete	1	sufficient to provide a crack-free surface
<b>Ceilings</b>		
Concrete	2	10mm (maximum)
Plasterboard	1	skimcoat

**(e) application**

### SCHEDULING OF WORK

Plastering should not be carried out in weather which could adversely affect the finished result. Any plaster damaged by frost should be removed and replaced (reference should be made to Chapter 1.4 'Cold weather working').

### MIXING

Materials should be mixed thoroughly, but prolonged mixing should be avoided. Avoid mixing more plaster than can be applied before it starts to set. Plaster should not be re-tempered.

### PROTECTION

The completed work of other trades, especially timber, chipboard and glazing, should be protected from damp and damage during plastering.

### PREPARATION

Before plastering is started, all surfaces should be dry, clean, and free from laitance, grease, loose material or any substance likely to prove harmful to the bond or the intended finished appearance of the plaster.

Joints between boarded or slab surfaces should be scrimmed, paper taped or otherwise treated as recommended by the manufacturer.

Dubbing out should be done well in advance of the application of the first coat.

### PLASTERING

The background surface should be fully set for each coat of plaster. The surface should not be overworked and adequate time should be left between coats to allow strength and suction to develop.

**(f) quality of finish**

All plastered surfaces should be reasonably plane and true and with a quality of finish appropriate for the location and intended use.

Reveals, soffits to openings, external angles and the like, should be reasonably plumb and level, and ceiling lines and corners should be regular.

Particular care should be taken in areas around wall light points, wall light switches and socket outlets.

**(g) plastic compound finish**

Plastic compound finishes should be applied by suitably trained operatives.

## PLASTERBOARD AND DRY LINING

**8.2 - S3 Plasterboard and dry lining shall be suitable for the intended decorative finish**

Items to be taken into account include:

**(a) background**

### EVENNESS AND STRENGTH

Plasterboard thickness should be correct for the support spacing.

Maximum limits are as follows:

Board thickness (mm)	Timber support centres (mm)	Intermediate noggings required	Perimeter noggings required
9.5	400	No	Yes
	450	Yes	Yes
12.5	400	No	Yes
	450	No	Yes
15	600	Yes	Yes
	600	No	No

### Notes

- Cut edges should only be used at perimeters. In all other situations cut edges should finish over a support or noggings.
- Additional intermediate noggings may be required where fire resistance is necessary.

When double layers of plasterboard for ceilings are specified, the joints of one layer should not coincide with those of the other. The first layer should be fully fixed and have all cut edges supported. The second layer should be supported on all edges with noggings provided to suit.

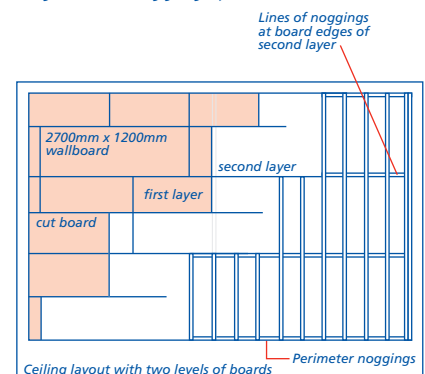



# 8.2 Wall and ceiling finishes

## SERVICES

There should be adequate support for:

- light points
- socket outlets
- other service installations.

Openings in plasterboard for services and electrical outlets should be accurately cut and any gaps in vapour control layers taped and sealed, as detailed in Chapter 6.2 'External timber framed walls'.

## WATER VAPOUR RESISTANCE

Install vapour control layers where specified. Edges should be lapped over supports and be taped or sealed.

### (b) surface finish

Plasterboard should be fixed face side out for both plastering and direct decoration finishes.

Tapered edge boards should be used for surfaces to be decorated directly on the board surface.

### (c) scheduling of work

Plasterboard work should:

- not be started until the building is substantially weatherproof
- be programmed so that finishes are applied as soon as possible after completion.

### (d) fixing

Fixing methods should be as follows:

- nails : hot dip galvanised, zinc electroplated or sheradised steel
- screws : zinc electroplated or black phosphate

(or to the board manufacturer's recommendations).

Fixings should be as follows:

Board thickness (mm)	Nail length (mm)	Screw length (mm) into timber	Screw length (mm) into steel
9.5	30	32	22
12.5	40	36	22
15	40	36	25

Nails or screws should be not less than:

- 10mm from paper bound edges
  - 13mm from cut ends of boards
  - 6mm from edges of timber members.
- Nail and screw heads should not project above the board surface.

Fixing centres should be as follows:

- nailing to: walls and ceilings - approximately 150mm centres (8 per linear metre)
- screwing to: walls - approximately 300mm centres (8 per 2 linear metres)  
ceilings - approximately 230mm centres (5 per linear metre).

## DRY LINING ON ADHESIVE DABS

Boards should be fixed to a pattern of adhesive dabs, at approximately 300mm

centres vertically, and as shown in the following table:

Thickness of wall board [mm]	Width of wall board [mm]	Dabs per board [rows]
9.5	900	3
9.5	1200	4
12.5	1200	3

Dabs should be applied to one board at a time.

## MECHANICAL FIXINGS FOR THERMAL WALLBOARDS

At least 2 nailable plugs should be used per board in accordance with the manufacturer's recommendations.

## PROPRIETARY SYSTEMS

Proprietary dry lining systems should be fixed in accordance with the manufacturer's recommendations.

### (e) jointing

Where surfaces are to receive skim coat plaster, joints should be scrimmed or paper taped in accordance with the manufacturer's recommendations. Ceiling boards should be staggered to minimise any risk of cracking.

For unskimmed surfaces, joints should be filled, taped or finished as recommended by the manufacturer.

### (f) gap sealing

A continuous ribbon of adhesive should be applied to the perimeter of external walls, openings and services in drylined walls to prevent air infiltration.

In addition:

- dry linings should be completely taped and filled at board joints and at abutments to ceilings and internal walls
- dry wall lining at door and window openings should be securely fixed and filled. This also applies at external and internal corners
- gaps around service points, electric sockets, light switches, etc should be filled with jointing compound.

### (g) appearance

Unless designed otherwise, intersections should be formed at right angles and be flush. Junctions at floors and ceilings should be neat and regular.

Dry lining to be finished fair should be of a quality recommended by the manufacturer. Damaged boards should not be used.

## CERAMIC WALL TILING

### 8.2 - S4 Ceramic wall tiling shall provide a surface adequate for its intended use

Items to be taken into account include:

#### (a) background

##### EVENNESS

The background to be tiled should be reasonably true so that a plane tile surface

can be achieved. Under a 2m straight-edge, gaps should not be greater than:

- 3mm - for *thin* bed adhesives
- 6mm - for *thick* bed adhesives.

## STRENGTH

The surface should be strong enough to accept the specified adhesive and support the tiling. Separate coats should be well bonded.

## BOND

The background should provide a satisfactory key. Backgrounds may be improved by:

- raking out masonry joints
- hacking and scratching
- applying a bonding agent.

## UNIFORMITY

Metal lathing or wire netting should be fixed across junctions where differential movement might occur.

## SUCTION

Suction of the background should be adequate and reasonably consistent. Where different materials could cause cracks, eg across junctions, appropriate precautions should be taken, eg by fixing metal lathing.

## WETTING

Where repeated or persistent wetting may occur, gypsum plasters should not be used. Plasterboard should be moisture resistant grade.

## HEATING

Gypsum plasters should not be used where repeated or persistent heating occurs, eg on flues or near heat sources.

### (b) adhesives

Tiles should be fixed as specified, using cement mortar or proprietary adhesive in accordance with manufacturers' instructions. Adhesives for tiles subject to frequent wetting should be water resistant.

### (c) application

#### PREPARATION

Before tiling is started, surfaces should be dry, clean, and free from laitance, grease, loose material or any substance likely to prove harmful to the bond or the intended finished appearance of the tiling.

#### FIXING

In wet areas, tiles should be solidly bedded in adhesive.

Tiles should be fixed in straight and even courses to form a plane surface. Work generally should be of a straight and regular appearance. Take particular care where lighting points are close to the tiled surface, such as above washbasins in bathrooms.

#### JOINTING

Joints should be even and cutting neatly carried out. Make sure that the spacing is sufficient to allow expansion.



## GROUTING

Grouting should be the specified mix and colour. The specified sealing method should be used at junctions between tiling and sanitary fittings.

Proprietary water resisting grouting should be used in accordance with manufacturers' recommendations.

## EDGING

There should be no cut or unfinished tiles at exposed edges or external corners.

## (d) movement

Properly designed movement joints should be:

- built into tiling at centres not exceeding 4.5m both vertically and horizontally
- at all vertical corners in large tiled areas
- located at junctions with other surfaces or backgrounds.

Tiles without spacer lugs should have a minimum joint width of 1-2mm to relieve local stress.

## APPENDIX 8.2-A

### Dry lining to receive ceramic wall tiling

Description	Board thickness mm	Support centres mm	Additional support	Max. height mm	Comments
Timber frame	12.5, 15	400 to 450	No	3600	
		600	Timber noggings 600 mm centres vertically	3600	
Timber battens	12.5, 15	400	Battens at head, base and intermediate positions not exceeding 1200 mm centres	3600	
Direct bond	9.5	450 dabs of adhesive in rows	Horizontal dabs at mid-storey height	3600	Complete at least 10 days before tiling
Direct bond (Thermal laminates)	12.5, 15	600 dabs of adhesive in rows	Horizontal dabs at mid-storey height	3600	Complete at least 10 days before tiling
Metal furring	12.5, 15	400 metal furring sections	Metal furring stops at head, base and intermediate positions not exceeding 1200 mm centres	3600	Complete at least 10 days before tiling
Resin base adhesive (Thermal laminates)	All	Blob of sealant	9 nailable plugs per board		
Independent steel stud lining					
48 mm	2 x 12.5	400	Mid-point support	3000	
60 mm	2 x 12.5		Mid-point support	3600	
48 mm metal stud partitions	15	400		2700	
	2 x 12.5 each side 2 x 15 each side	400		3600 3600	
70 mm metal stud partitions	15	400		3600	
	2 x 12.5 each side 2 x 15 each side	400		3600 3600	
146 mm metal stud partitions	2 x 15 each side	600	Additional stud at 300 mm up to tile height	3600	
Prefabricated gypsum wallboard panel partition	57	} Normal specification		2700	
	63				
Laminated partition	50	} Normal specification		2600 2800	Complete at least 10 days before tiling
	65				

## INDEX

### A

Adhesive dabs	4
Adhesives, ceramic tiling	4

### B

Background, plastering	1, 3
------------------------	------

### C

Ceilings	3
Ceramic tiling	2, 5

### D

Decorative finish	1
Dry lining	1, 2, 3, 4, 5

### F

Fire resistance	1
Fixings	1, 2, 4

### G

Gaps, sealing	2, 4
---------------	------

### M

Metal laths and beads	2
Movement	5

### N

Noggings	3
----------	---

### P

Plaster mix	3
Plasterboard	1
Plastering	1, 3
Plasters	2
Plastic compound finishes	2
Proprietary systems	4

### R

Render	2
--------	---

### S

Services	1, 3, 4
Sound insulation	1

### T

Tile quality	2
--------------	---

### V

Vapour control layer	4
Vapour resistance	4



# Chapter 8.3

## Floor finishes

---



# 8.3 Floor finishes

## CONTENTS

	Clause	Page
<b>DESIGN</b>		
Design standards	D1	1
Statutory requirements	D2	1
Screeding	D3	1
Ceramic, concrete, terrazzo and similar tilefinishes	D4	1
Asphalt finishes	D5	1
Flexible sheet and tile finishes	D6	2
Woodfinishes	D7	2
Staircase finishes	D8	2
Provision of information	D9-D10	3
<b>MATERIALS</b>		
Materials standards	M1	3
Screeding materials	M2	3
Ceramic, concrete, terrazzo and similar tilefinishes	M3	3
Asphalt finishes	M4	3
Flexible sheet and tile finishes	M5	3
Woodfinishes	M6	3
Sound insulation	M7	3
Thermal insulation	M8	4
Structural floor decking	M9	4
<b>SITWORK</b>		
Sitework standards	S1	4
Screeding	S2	4
Ceramic, concrete, terrazzo and similar tilefinishes	S3	5
Asphalt finishes	S4	5
Flexible sheet and tile finishes	S5	5
Woodfinishes	S6	6
Staircase finishes	S7	6
<b>INDEX</b>		6

## SCOPE

This Chapter gives guidance on meeting the Technical Requirements and recommendations for floor finishes, including integral insulation, screeds, ceramic, concrete and similar tiles, flexible sheet and tiles, wood block and asphalt.

**DESIGN STANDARDS**

**8.3 - D1 Design shall meet the Technical Requirements**

Design that follows the guidance below will be acceptable for floor finishes.

**STATUTORY REQUIREMENTS**

**8.3 - D2 Design shall comply with all relevant statutory requirements**

Designs should be in accordance with relevant Building Regulations and other statutory requirements.

**SCREEDING**

**8.3 - D3 Floor screeds shall be suitable for their intended use**

Items to be taken into account include:

**(a) background**

**BOND**

Background surfaces for bonded screeds should provide an adequate mechanical key. If necessary, cement grouting or a bonding agent should be specified to provide adequate adhesion.

**MOISTURE PROTECTION**

The floor design should ensure that moisture from the ground does not enter the dwelling. For details, reference should be made to Chapters 5.1 'Substructure and ground bearing floors' (Design) and 5.2 'Suspended ground floors' (Design).

**(b) services**

Provision should be made for:

- thermal movement of water pipes
- protection against chemical attack, for example by using purpose-made pipe sleeves or ducts.

**(c) screed mix**

Cement and sand screeds should normally be a mix between 1 : 3 and 1 : 4½. Screeds more than 40mm thick may be of concrete.

Proprietary additives should have been assessed in accordance with Technical Requirement R3.

**(d) screed thickness**

Cement and sand screeds should be not less than the following thickness:

Method of laying	Minimum thickness at any point(mm)
Laid monolithically with base	12
Laid on and bonded to a set and hardened base	20
Laid on a separating membrane (eg 1000g polyethylene)	50
Laid on resilient slabs or quilts (screed reinforced with galvanized wire mesh)	65
Above services, reinforcement or insulation to services	25

For concrete ground bearing floors, up to 20mm thickness of monolithic screed may be acceptable as part of the required thickness.

Where service pipes are bedded in the screed, the screed should be deep enough to provide at least 25mm of cover over pipes and insulation.

**(e) bay size**

Screeds over underfloor heating should be sub-divided into bays not exceeding 40m<sup>2</sup> in area. Otherwise, room size laying is preferable. Expansion joints in screeds should be consistent with joints in the slab.

**(f) curing**

A curing period should be allowed until the screed achieves sufficient strength to resist shrinkage stresses and other damage.

**(g) surface quality**

**SCREDS UNDER FINISHES**

Screeds intended to be covered with floor finishes should provide an even surface as appropriate.

Recommendations for screeds suitable for various floor finishes are given in the British Standards referred to in Materials clause 8.3 - M2. BS 8204 gives recommendations for screeds to receive in-situ floorings.

**POWER FLOATED FINISH**

Concrete floor slabs may be suitably finished to serve directly as a wearing surface without the need for an additional topping, in accordance with recommendations of BS 8204.

**USE OF SEALERS OR HARDENERS**

If required, surface sealers or hardeners should only be used in accordance with manufacturers' instructions.

**(h) moisture content**

The moisture content of screeds to receive other finishes, should be:

- generally in accordance with relevant British Standards
- in accordance with floor finish manufacturers' recommendations, where available.

**(i) thermal insulation material below screeds**

Insulation below screeds should provide adequate compressive strength to support wet construction screeds and floor loads.

Suitable materials are described in clause M8. Insulants should be compatible with any dpm in contact with the insulation.

**(j) sound insulation material below screeds**

Screeds above compressible material in sound insulating floating floors should be laid on an isolating membrane (for

example building paper) and reinforced with galvanized wire mesh.

Suitable insulation materials are described in clause M7.

**CERAMIC, CONCRETE, TERRAZZO AND SIMILAR TILE FINISHES**

**8.3 - D4 Tile floorings shall provide a suitable surface for the intended use**

Items to be taken into account include:

**(a) background**

**EVENNESS**

The substrate should provide a plane surface. Falls should be specified where required.

**MOISTURE PROTECTION**

Where floor tiling is laid above ground bearing floor slabs, a dpm should be incorporated below or above the floor slab.

**(b) application**

Floor tiling should be in accordance with the recommendations of BS 5385 : Part 3. Care should be taken to ensure that:

- the concrete base or screed is true and level
- sufficient drying time has been allowed, ie at least 6 weeks for concrete base, 3 weeks for screed.

**TILES ON WOOD-BASED SUBSTRATE**

The floor should be designed to take the additional loads of tiles and any other materials (e.g. overlays). Tiles should be suitable for laying over a timber base.

The floor decking should be:

- plywood for use in exterior conditions (minimum 15mm for joists at 400/450mm centres and minimum 18mm for joists at 600mm centres) screwed to the joists at 300mm centres with all square edges supported on joists or noggins. Plywood should be laid with a 1.5-2mm movement gap between boards and at abutments
- chipboard floor decking overlaid with minimum 10mm plywood suitable for exterior conditions and fixed as above, or proprietary separating/de-coupling layers, tile backer boards or tile bedding reinforcement sheets used in accordance with the manufacturer's recommendations.

Deformable (flexible) tile adhesive (e.g. C2S1) and grout should be used in accordance with the adhesive manufacturer's recommendations.

**ASPHALT FINISHES**

**8.3 - D5 Asphalt finishes shall be suitable for their intended use**

Asphalt floor finishes should be in accordance with BS 6925 (limestone aggregate). Suitable thicknesses and grades include:

# 8.3 Floor finishes

Use	Thickness (mm)	Grade
Floorfinish	15 to 20	I or II
Underlay for other finishes (in one coat)	15 to 20	I or II

Suspended floor system manufacturers should be consulted where mastic asphalt floor finishes are to be used with such systems.

## FLEXIBLE SHEET AND TILE FINISHES

### 8.3 - D6 Flexible sheet and tile flooring shall provide a suitable surface for the intended use

Items to be taken into account include:

#### (a) background

BS 8203 gives recommendations on the use of flexible sheet and tile floorings.

#### EVENNESS

Substrates should be sufficiently level to achieve an acceptable floor surface. If necessary, a levelling underlay should be provided.

Acceptable types of underlay for boarded surfaces include the following:

Type of underlay	Minimum thickness (mm)
Hardboard	3.2
Plywood	4.0
Chipboard	9.0
Oriented strand board	6.0

#### MOISTURE PROTECTION

Where flexible sheet or tile flooring is laid on ground bearing concrete floors, a dpm should be incorporated to prevent rising moisture adversely affecting floor finishes.

Screeds or concrete surfaces should be sufficiently dry to avoid any adverse effects on the flooring.

Where there is a risk of trapping moisture from spillage or interstitial condensation, permeable finishes should be used.

#### (b) laying and fixing

Flexible tiles and sheets should be laid, using the adhesive and the method recommended by the manufacturer.

Special precautions, such as welded seams, may need to be specified to prevent curling, bubbling and lifting.

#### (c) accessories

Skirtings should be specified, where appropriate.

## WOOD FINISHES

### 8.3 - D7 Wood and wood-based flooring shall be designed to provide a suitable wearing surface for the intended use

Items to be taken into account include:

#### (a) background

BS 8201 gives recommendations on the use of wood and wood-based floorings for directly and indirectly applied finishes.

BS 5250 gives recommendations on the use of vapour control layers with wood and wood-based floorings.

Screeds or concrete to receive wood flooring should be sufficiently dry to avoid any adverse effects. Tests for moisture content are given in BS 8201.

A damp-proof membrane should be incorporated as appropriate.

#### DIRECTLY APPLIED FINISHES

(wood blocks, parquet, wood mosaic, etc) Floor finishes should be applied with the correct adhesives, for example:

- bitumen rubber emulsion (in accordance with BS 8201)
- proprietary adhesives (assessed in accordance with Technical Requirement R3) in accordance with manufacturers' instructions.

Screeds or concrete surfaces to receive wood finishes:

- should be treated with a suitable primer where recommended by the adhesive manufacturer.

#### INDIRECTLY APPLIED FINISHES

(softwood boarding, wood-based panel products)

The following precautions should be taken:

- vapour control layers may need to be incorporated above the insulation
- battens should be preservative treated in accordance with recommendations given in Chapter 2.3 'Timber preservation (natural solid timber)'
- provision should be made for local support for heavy items such as storage heaters, boilers, etc
- battens should be at appropriate centres, generally in accordance with the following:

Thickness of finish (mm)	Maximum batten centres (mm)
--------------------------	-----------------------------

#### Chipboard (type P5)

18/19	450
22	600

#### Plywood

15	450
18	600

#### Oriented strand board (type OSB3)

15	450
18-19	600

- fixings to battens should prevent excessive movement and should be in accordance with manufacturers' recommendations.

#### (b) services

Wherever possible, services beneath the floor finish should be tested before floor laying is commenced.

#### (c) sound insulation

Floating floor finishes should be designed to:

- isolate the floor finish from the supporting floor and all walls
- avoid excessive movement or squeaking
- avoid the use of fixings which penetrate the insulation layer.

Floors should be designed so that there are no airpaths, especially at the perimeter. This limits the transfer of airborne sound and avoids flanking transmission.

#### SOFT FLOOR COVERING

Where a floor relies on a soft floor covering to provide the minimum standard of sound insulation, the covering should be fixed permanently in position.

#### (d) thermal insulation

Methods of providing insulation include the following:

- insulation above in-situ concrete slab (dpm required)

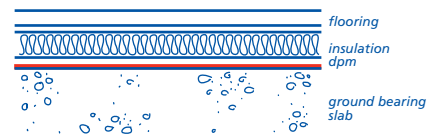

- insulation above dry, precast system (dpm NOT required).

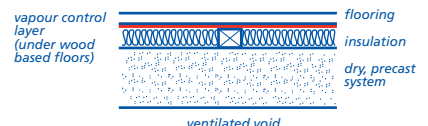

Proprietary insulated flooring should be assessed in accordance with Technical Requirement R3. Manufacturers' recommendations regarding provision of vapour control layers and damp-proof membranes should be followed.

Further information can be found in BS 5250 and the BRE Report 'Thermal insulation: avoiding risks'.

## STAIRCASE FINISHES

### 8.3 - D8 Staircase finishes shall allow safe use of the staircase

Items to be taken into account include:

#### (a) rise and going

Staircase pitch and tread dimensions are specified in Chapter 6.6 'Staircases' (Design). It is important that rise and going remain consistent and are not affected by the staircase finish, particularly at the top and bottom of the flight.

#### (b) slip resistance

Guidance on staircase finishes of flexible sheet or tiles is included in BS 8203.

Communal staircases, such as those providing means of escape in fire, should be provided with a non-slip surface or nosing.

## PROVISION OF INFORMATION

**8.3 - D9 Designs and specifications shall be produced in a clearly understandable format and include all necessary information**

Drawings and specifications should cover at least:

- schedule of finishes
- screed thickness and mix
- details of sound insulating floors
- extent and detail of tiled surfaces
- location of services adjacent to tiled surfaces
- details of staircase finishes.

**8.3 - D10 All relevant information shall be distributed to appropriate personnel**

Ensure that design and specification information is issued to site supervisors and relevant specialist sub-contractors and/or suppliers.

## MATERIALS STANDARDS

**8.3 - M1 All materials shall:**

- (a) meet the Technical Requirements
- (b) take account of the design

Materials that comply with the design and the guidance below will be acceptable for floor finishes.

Materials for floor finishes shall comply with all relevant standards, including those listed below. Where no standard exists, Technical Requirement R3 applies (see Chapter 1.1 'Introduction to the Standards and Technical Requirements').

References to British Standards and Codes of Practice include those made under the Construction Products Directive (89/106/EEC) and, in particular, appropriate European Technical Specifications approved by a European Committee for Standardisation (CEN).

## SCREEDING MATERIALS

**8.3 - M2 Materials selected for screeding shall be adequate for the location and intended use**

Relevant standards include:  
BS 8204 In-situ floorings

The following standards include references to concrete and screed as sub-base:

- BS 8201 Code of Practice for flooring of timber, timber products and wood-based panel products
- BS8203 Code of Practice for installation of sheet and tile flooring
- BS5385 Wall and floor tiling.

## CERAMIC, CONCRETE, TERRAZZO AND SIMILAR TILE FINISHES

**8.3 - M3 Materials for tile flooring shall be adequate for the location and intended use**

BS 5385 Wall and floor tiling contains references to materials for ceramic, concrete and similar floor tiles.

Items to be taken into account include:

### (a) ceramic tiles

Relevant standards include:

- BS 5385 Code of Practice for the design and installation of ceramic floor tiles and mosaics.
- BS EN14411 Ceramic tiles. Definitions, classification, characteristics and marking.

### (b) terrazzo tiles

Relevant standards include:

- BS EN 13748: Terrazzo tiles Parts 1 and 2
- BS8204 Screeds, bases and in situ floorings. Concrete bases and cement sand levelling screeds to receive floorings.

## ASPHALT FINISHES

**8.3 - M4 Materials for asphalt flooring shall be adequate for the location and intended use**

Relevant standards include:

- BS 6925 Specification for mastic asphalt for building and civil engineering (limestone aggregate).

## FLEXIBLE SHEET AND TILE FINISHES

**8.3 - M5 Materials for flexible sheet and tile flooring shall be adequate for the location and intended use**

Relevant standards include:

- BS EN 649 Resilient floor coverings. Homogenous and heterogenous polyvinyl chloride floor coverings.
- BS EN654 Resilient floor coverings. Semi-flexible polyvinyl chloride tiles.
- BS EN650 Resilient floor coverings. Polyvinyl chloride floor coverings on jute backing or on polyester felt backing or on polyester felt with polyvinyl chloride backing.

- BS EN651 Resilient floor coverings. Polyvinyl chloride floor coverings with foam layer.
- BS EN12104 Resilient floor coverings. Cork floor tiles.

The following standard contains further specification details for flexible sheet and tile flooring:

- BS 8203 Code of Practice for installation of resilient floor coverings.

## WOOD FINISHES

**8.3 - M6 Materials for wood flooring shall be adequate for the location and intended use**

### ALL WOOD AND WOOD-BASED MATERIALS

Relevant standards include:

- BS 8201 Code of Practice for flooring of timber, timber products and wood-based panel products.

### DIRECTLY APPLIED FINISHES

(wood blocks, parquet, wood mosaic, etc)

Relevant standards include:

- BS 1187 Specification for wood blocks for floors
- BS4050 Specification for mosaic parquet panels.

### INDIRECTLY APPLIED FINISHES

(softwood and hardwood boarding, wood-based panel products, etc)

Relevant standards include:

- BS 1202 Specification for nails
- BS1210 Specification for wood screws
- BS1297 Specification for tongued and grooved softwood flooring
- BS EN312 Part 2: Specification for wood chipboard Particleboard
- BS EN300 Part 3: Specification for oriented strand Particleboard board (OSB)
- BS EN636 Plywood.

## SOUND INSULATION

**8.3 - M7 Sound insulation materials shall provide adequate insulation standards in their intended location**

Information concerning materials and constructions that will generally be acceptable is given in statutory regulations.

Proprietary products should have been assessed in accordance with Technical Requirement R3.

Sound insulation materials include:

- flexible material
- mineral fibre quilt insulation
- board material (for use under screeds)



# 8.3 Floor finishes

- pre-compressed expanded polystyrene - impact sound duty (ISD) grade
- proprietary materials which have been assessed in accordance with Technical Requirement R3.

## THERMAL INSULATION

### 8.3 - M8 Thermal insulation materials shall provide adequate insulation standards in their intended location

Floor insulation materials should include the following:

Material	BS	Grade or description
EPS (expanded polystyrene)	EN13163	70
PUR (rigid polyurethane)		for use under screeds
PIR (rigid polyisocyanurate)	4841	
Fibre building board	1142 Part 3	insulating board (softboard)
Proprietary materials assessed in accordance with Technical Requirement R3	-	-

Insulation materials for use below screeds should:

- have adequate compressive strength to support wet construction screeds and floor loads
- be compatible with any dpm, where appropriate.

## STRUCTURAL FLOOR DECKING

### 8.3 - M9 Structural floor decking materials shall be suitable for their purpose and location

Decking materials should be selected in accordance with the relevant parts of Chapter 6.4 'Timber and concrete upper floors' (Design and Materials).

## SITWORK STANDARDS

### 8.3 - S1 All sitework shall:

- (a) meet the Technical Requirements
- (b) take account of the design
- (c) follow established good practice and workmanship

Sitework that complies with the design and the guidance below will be acceptable for floor finishes.

## SCREEDING

### 8.3 - S2 Floor screeds shall be laid to provide a suitable background for the intended floor finishes

Items to be taken into account include:

#### (a) background

##### MOISTURE PROTECTION

Check that any specified damp-proofing treatment has been completed before screeding is commenced.

##### SURFACE PREPARATION

All surfaces should be clean and dust free. In particular, any traces of gypsum should have been removed. Concrete surfaces should be wetted and brushed before screeding.

##### BOND

Where screeds are to be bonded to the substrate, the surface should provide adequate bond. If necessary, the surface should be improved by:

- hacking
- roughening
- grouting
- application of a bonding agent.

#### (b) services

Provision should be made for:

- thermal movement of water pipes
- protection against chemical attack, for example by using purpose-made sleeves or ducts, see Chapter 8.1 'Internal services' (Design and Sitework).

There should be at least 25mm thickness of screed above the highest point of any service pipe or insulation placed around the pipe.

#### (c) mixing

Cement and sand screeds should be mixed in the specified proportions.

Proprietary screeds should be mixed in accordance with the manufacturer's recommendations.

#### (d) laying

##### WEATHER CONDITIONS

Screeding should not be carried out under weather conditions which could adversely affect the result. The following precautions should be taken:

- hot or dry weather - screeds should not be laid in hot or dry weather unless precautions are taken to prevent the screed surface drying out too quickly
- frost - screeds should not be laid if there is a risk of freezing.

Any screeds damaged by frost should be removed and replaced (reference should be made to Chapter 1.4 'Cold weather working').

#### TIMING

Monolithic screeds should be laid within three hours of the concrete sub-floor being poured.

Wet screeding should be programmed to allow sufficient drying out time before dry lining is to commence.

#### BAY SIZE

Screeds above underfloor heating should not exceed 40m<sup>2</sup> with a maximum length of 8m.

#### THICKNESS

Screeds should be laid to the specified thickness.

#### COMPACTION

Screeds should be thoroughly compacted, using a heavy tamper or a mechanical compactor or vibrator.

Proprietary screeds should be laid in accordance with manufacturers' recommendations.

#### (e) protection, curing

Screed surfaces should be protected against damage from traffic and be kept continuously moist until sufficient strength has been attained to resist shrinkage stresses (at least 7 days).

#### (f) surface finish

##### SCREDS PROVIDING A WEARING SURFACE

Floor screeds to be left as a wearing surface should be either treated with a surface hardener in accordance with manufacturers' recommendations or be power floated to a smooth and durable surface.

##### SCREDS TO RECEIVE A FLOOR FINISH

Where a screed is to be used as a sub-base for a floor finish, the surface should be suitable for the required finish as specified in the design.

#### (g) screeds on resilient insulation materials

Screeds above resilient insulating materials should be laid on a separating membrane and reinforced as specified.

The slabs of resilient material should be tightly butted, and turned up at the room perimeter to prevent contact between the screed and the structure which could create sound transmission paths.

Joints in the isolating membrane should be lapped and taped. The membrane should be turned up at the perimeter to prevent grout seeping through.

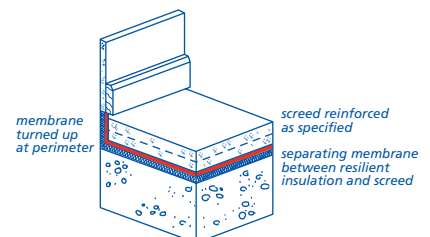

#### (h) screeds on thermal insulation

The procedure for laying screeds on resilient materials should be followed. Turning up insulation at perimeters prevents cold bridging.

## CERAMIC, CONCRETE, TERRAZZO AND SIMILAR TILE FINISHES

### 8.3 - S3 Tile flooring shall provide a suitable surface for the intended use

Items to be taken into account include:

#### (a) background

##### EVENNESS

The background to be tiled should be reasonably even and laid to falls where required.

##### PREPARATION

Before bedding is commenced, the following precautions should be taken:

- the surface should be clean and free from all laitance, dirt, dust, grease and any other material incompatible with the adhesive
- where appropriate, a damp-proof membrane should have been incorporated
- differences in level should be dubbed out
- the screed or concrete surface should be true and level ( $\pm 3\text{mm}$  under a 3m straight edge)
- the screed or base should be sufficiently dry.

#### (b) bedding

Cement and sand mortar should normally be a mix between 1 : 3 and 1 : 4½.

Where proprietary mortars or adhesives are used, manufacturers' recommendations should be followed.

#### (c) laying

Floor tiles should be bedded in a solid bed of mortar or proprietary adhesive of a thickness appropriate for the material. The tiles should be arranged to minimise cutting with straight joints of even width. Any cutting necessary should be done neatly and accurately.

#### (d) jointing

For ceramic tiles, joints should be not less than 3mm wide.

Movement joints should be provided around the floor perimeter and at rigid upstands. In large areas tiling should be divided into bays at 8-10m centres.

#### (e) grouting

Grout should be a cement based epoxy resin or a proprietary product. Where tiles may become saturated the grout should be water resistant.

#### TILES ON WOOD-BASED SUBSTRATE

The floor decking should be:

- plywood for use in exterior conditions (minimum 15mm for joists at 400/450mm centres and minimum 18mm for joists at 600mm centres) screwed to the joists at 300mm centres with all square edges supported on joists or noggins. Plywood should be laid with a 1.5-2mm movement gap between boards and at abutments, and be acclimatised to the room conditions and sealed on the underside and square edges, before laying, with a suitable sealer such as polyurethane varnish

- chipboard floor decking overlaid with minimum 10mm plywood suitable for exterior conditions, acclimatised, sealed and fixed as above, or proprietary separating/de-coupling layers, tile backer boards or tile bedding reinforcement sheets used in accordance with the manufacturer's recommendations.

Floor tiles on wood based substrates should be bedded with deformable (flexible) tile adhesive (e.g. C2S1) and grouted in accordance with the manufacturer's recommendations.

Tiles should be laid with minimum 3mm joints unless otherwise specified by the manufacturer. Movement joints should be provided at rigid abutments where tiled areas exceed 2m in length.

#### (f) accessories

Any accessories, such as covings, skirtings, etc, should match the tile pattern and be fixed so that joints are aligned with those in the floor.

#### (g) protection

Where necessary, tile flooring should be protected until the dwelling is handed over. Temporary covering should be building paper or an alternative material which will withstand traffic from other trades and any plaster droppings or other spillage.

## ASPHALT FINISHES

### 8.3 - S4 Asphalt and pitch mastic shall be suitable for its use

Suitable thicknesses and grades include:

Use	Thickness (mm)	Grade
Floorfinish	15 to 20	I or II
Underlay for other finishes in one coat	15 to 20	I or II

Suspended floor system manufacturers should be consulted where mastic asphalt floor finishes are to be used with such systems.

## FLEXIBLE SHEET AND TILE FINISHES

### 8.3 - S5 Flexible sheet and tile floor finishes shall be laid to provide a suitable wearing surface

Items to be taken into account include:

#### (a) background

##### MOISTURE PROTECTION

The substrate should be sufficiently dry to prevent any adverse effect on the flooring.

Where applicable, manufacturers' recommendations should be followed.

##### EVENNESS

The surface should be even and without high spots or cracks. Where a levelling underlay is needed, it should be of a type and thickness recommended by the flooring manufacturer.

Boarded surfaces may be covered by a sheet underlay.

The following types are acceptable:

Type of underlay	Minimum thickness (mm)
Hardboard	3.2
Plywood	4.0
Chipboard	9.0
Oriented strand board	6.0

#### (b) laying

##### CONDITIONING

Flexible and sheet flooring materials should be stored in a clean and ventilated place. Unless specifically permitted by the manufacturer, materials should not be stored in cold conditions. The temperature should be not less than 18°C for at least 24 hours before and during laying.

##### UNDERLAYS

Plywood or hardboard underlays should be fixed with ring shank nails or staples; and chipboard and oriented strand board with ring shank nails or screws, 2½ times the thickness of the boards.

Fixings for plywood or hardboard should be at 100mm centres at perimeters (12mm from edges) and 150mm centres across the sheets; and for chipboard and oriented strand board, at 300mm centres at perimeters (9mm from edges) and 400mm centres across the boards.

Measures should be taken to prevent damage to underfloor services.

##### FLOORING

Sheet or tile flooring should be fixed with the specified adhesives and in accordance with manufacturers' instructions.

Flooring should be fully bonded, where appropriate. Adhesives should be spread evenly, and dry and contact adhesives left for the correct period of time to ensure full bonding. Provision for adjustment after initial contraction or expansion should be made where necessary.

Welded joints should be provided, where specified, in accordance with manufacturers' recommendations.

The flooring should be pressed down firmly where appropriate, surplus adhesive removed, and the completed surface loaded or rolled as necessary to prevent curling or bubbling.

#### (c) fittings

Where specified, skirtings, covings, coverstrips and other pre-formed components should be fixed in accordance with manufacturers' recommendations.

#### (d) quality of finish

The floor finish should be reasonably level and smooth. Particular care should be taken at doorways and junctions. Flooring should be cut so that it fits neatly around fittings, pipes, etc.

# 8.3 Floor finishes

## (e) protection

All sheet or tile flooring should be kept protected until handover of the dwelling. Temporary covering should be building paper or other material, which will withstand traffic from other trades and any dampness caused by plaster droppings or spillage.

## WOOD FINISHES

### 8.3 - S6 Wood flooring shall be laid so as to be suitable for the intended use

Items to be taken into account include:

#### (a) moisture protection

For wood finishes to be laid directly on concrete slabs or screeds, the substrate should be sufficiently dry to prevent any adverse effects. To become sufficiently dry, a 50mm screed requires at least 2 months and a concrete slab requires at least 6 months. Alternatively, it should be tested for moisture content in accordance with BS 8201.

Where the above times are not practical a dpm or vcl should be incorporated in the floor construction to protect the wood finishes but not in such a way as to trap moisture between the two.

Wood finishes should be conditioned to the appropriate moisture content before laying.

#### (b) services

Underfloor heating, where installed, should be kept on before and during the floor laying.

#### (c) laying and fixing

### PREPARATION OF SCREEDS OR CONCRETE SURFACES

Preparation should be as follows:

- high spots, nibs and major irregularities should be removed
- differences in level should be dubbed out.

## DIRECTLY APPLIED FINISHES

(wood block and strip flooring)  
Wood block and strip flooring should be laid and fixed in accordance with manufacturers' recommendations, using the specified or recommended adhesive as appropriate.

Adhesive should be evenly spread, and blocks laid to the specified pattern, leaving gaps around the perimeter for movement.

## INDIRECTLY APPLIED FINISHES

(softwood boarding, wood-based panel products)

- *batten spacing* - battens should be at centres appropriate to the floor finish material, and generally in accordance with the following:

Thickness of finish (mm)	Maximum batten centres (mm)
<b>Chipboard (type P5)</b>	
18/19	450
22	600
<b>Plywood</b>	
15	450
18	600
<b>Oriented strand board (type OSB3)</b>	
15	450
18-19	600

- *batten fixing to substrate* - battens may be shot-fired or fixed with suitable clips.
- *chipboard and oriented strand board fixed to battens*

Fixing	Length	Centres
Flatheaded ring shank nails or screws	2½x board thickness	200mm to 300mm centres around perimeters
		400mm to 500mm centres on intermediate supports

or in accordance with manufacturers' recommendations.

- *plywood fixed to battens*

Fixing	Centres
10 gaugenails or screws	150mm centres around perimeter
	300mm centres on intermediate supports
	nails/screws at least 10mm from edge of panel

or in accordance with manufacturers' recommendations.

## FLOOR COVERINGS LAID ON RESILIENT MATERIALS

Where flooring is to be laid on resilient materials on a separating floor, it is important that edges are isolated from walls and skirtings by a resilient layer.

## STRUCTURAL DECKING

Floor boards and decking should be laid and fixed as described in Chapter 6.4 'Timber and concrete upper floors' (Sitework).

## (d) protection

All wood flooring should be kept protected until handover of the dwelling. Temporary covering should be building paper or other material, which will withstand traffic from other trades and any dampness caused by plaster droppings or spillage.

## STAIRCASE FINISHES

### 8.3 - S7 Staircase finishes shall be suitable for their intended use

Items to be taken into account include:

#### (a) provision of slip resistant nosings

For communal stairs, eg in escape routes in blocks of flats, non-slip nosings or inserts should be provided where specified, and fixed in accordance with the manufacturer's recommendations.

#### (b) consistent rise and going

The rise and going should remain uniform after application of the staircase finish. Reference should also be made to Chapter 6.6 'Staircases' (Design and Sitework).

## INDEX

### A

Asphalt finishes 1, 3, 5

### B

Background, screeds 1, 4

Background, tiles 1, 5

Background, wood finishes 2

### C

Ceramic tiles 1, 3, 5

Chipboard 2, 6

Concrete tiles 1, 3, 5

Curing 1

### D

Decking 4

Directly applied finishes 2, 3, 6

### F

Flexible finishes 1, 3, 5

### I

Indirectly applied finishes 2, 3, 6

### M

Moisture protection 2, 4, 5

### O

Oriented strand board 2, 6

### P

Plywood 2, 6

### S

Screeds 1, 3, 4

Services 1, 2, 4, 6

Slip resistance 2, 6

Soft floor coverings 2

Sound insulation 1, 2, 3

Staircases 2, 6

Structural floor decking 4, 6

Surface finish, screeds 1, 4

### T

Terrazzo tiles 1, 3, 5

Thermal insulation 1, 2, 4

Tile floorings 1, 5

### W

Wood finishes 2, 3, 5

# Chapter 8.4

## Finishings and fitments

---



# 8.4

## Finishings and fitments

### CONTENTS

	Clause	Page
<b>DESIGN</b>		
Design standards	D1	1
Cupboards and fitments	D2	1
Finishings and internal trim	D3	1
Provision of information	D4	1
<b>MATERIALS</b>		
Materials standards	M1	1
Joinery	M2	1
Ironmongery	M3	1
Other materials	M4	2
Prefabricated items	M5	2
<b>SITWORK</b>		
Sitework standards	S1	2
Cupboards and fitments	S2	2
Finishings and internal trim	S3	2
Protection	S4	2
<b>INDEX</b>		3

### SCOPE

This Chapter gives guidance on meeting the Technical Requirements and recommendations for fitments and cupboards, internal trim and finishings.

### DESIGN STANDARDS

#### 8.4 - D1 Design shall meet the Technical Requirements

Design that follows the guidance below will be acceptable for finishings and fitments.

### CUPBOARDS AND FITMENTS

#### 8.4 - D2 The builder shall provide fixed and built-in fitments in accordance with the specification

Items to be taken into account include:

##### (a) kitchen facilities

The specification should cover space or facilities for:

- preparation and cooking of food
- washing up, drying and storage of dishes and utensils
- storage of dry foods
- storage of perishable foods
- laundering
- storage of domestic cleaning appliances, part of which should be suitable for brooms, upright cleaners and similar equipment.

Space or facilities for laundering and cleaning items may be provided outside the kitchen area.

A circulation space of not less than one metre should be provided in front of all work surfaces, cupboards and appliances provided. For design purposes, when work surfaces, cupboards and appliances are intended (but not provided) they should be assumed to be 600mm deep.

##### (b) storage space

Storage space should also include space or provision for:

- general storage
- storage of clothes, linen and bedding and, in homes which do not have central, or whole home, heating, their airing.

##### (c) airing cupboards

Airing cupboards are required in homes which do not have central, or whole home, heating. In other cases they are optional.

Where provided, airing cupboards should have:

- not less than 0.5m<sup>2</sup> of easily reached shelving suitable for the airing of clothes
- a vertical space between shelves of not less than 300mm
- a suitable heat source, such as a hot water cylinder or an equivalent.

Care is necessary when designing airing cupboards. To be accessible, the shelving should be placed not higher than 1.5m.

The airing area should be separated from other storage.

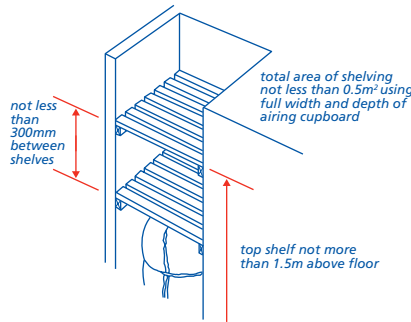

##### (d) hinges

To reduce movement and shrinkage, doors should be hung on hinges as follows:

Location of door	Hinges
Airing cupboard	1½ pairs x 75mm
Other internal fitments	1 pair x 75mm

### FINISHINGS AND INTERNAL TRIM

#### 8.4 - D3 Finishings and internal trim shall be suitable for their location and intended use

Items to be taken into account include:

##### (a) wood trim

All trim should be of adequate size to mask joints around built-in fitments, etc allowing for movement and shrinkage.

Any wood trim in the vicinity of fireplaces or heating appliances should be fixed at not less than the statutory minimum distance from heat sources and be arranged to minimise movement and shrinkage.

Special consideration should be given to the positioning of finishings and trim in relation to cable runs, light points, socket outlets, door furniture, handrails, balustrades, etc.

##### (b) non-wood trim

Proprietary trim items should be installed in accordance with the manufacturer's recommendations.

### PROVISION OF INFORMATION

#### 8.4 - D4 All relevant information shall be produced in a clearly understandable format and distributed to appropriate personnel

Ensure that design and specification information is issued to site supervisors and relevant specialist subcontractors and/or suppliers.

### MATERIALS STANDARDS

#### 8.4 - M1 All materials shall: (a) meet the Technical Requirements (b) take account of the design

Materials that comply with the design and the guidance below will be acceptable for finishings and fitments.

Materials for finishings and fitments should comply with all relevant standards including those listed below. Where no standard exists, Technical Requirement R3 applies (see Chapter 1.1 'Introduction to the Standards and Technical Requirements').

References to British Standards and Codes of Practice include those made under the Construction Products Directive (89/106/EEC) and, in particular, appropriate European Technical Specifications approved by a European Committee for Standardisation (CEN).

### JOINERY

#### 8.4 - M2 Wood and wood-based materials shall be of the quality and dimensions required by the design

Items to be taken into account include:

##### (a) classification

All wood and wood-based materials should, as a minimum, comply with the requirements of:

BS EN 942	Specification for timber : Timber for and workmanship in joinery : Class 3
BS EN 312	Particleboard.

##### (b) workmanship

All joinery items should be constructed to a good standard of workmanship including:

- fit and construction of joints
- construction of finger joints
- glueing and laminating
- construction of moving parts
- surface finishes.

Prefabricated components should comply with the relevant parts of BS 1186 : Part 2.

##### (c) surface finish

The prepared surface should be such that no defects are visible after the finish is applied.

### IRONMONGERY

#### 8.4 - M3 Ironmongery shall be provided in accordance with the design and specification

Relevant standards include:

BS EN 1935	<a href="#">Building hardware - single axis hinges - Requirements and test methods.</a>
------------	---



# 8.4

## Finishings and fitments

### OTHER MATERIALS

#### 8.4 - M4 Other materials shall be suitable for the intended use

Materials other than wood should be of the quality and dimensions required by the design and should be chosen in accordance with manufacturers' recommendations.

### PREFABRICATED ITEMS

#### 8.4 - M5 All prefabricated items shall be suitably protected against damage

Appropriate protection should be specified to reasonably ensure that items are undamaged.

### SITWORK STANDARDS

#### 8.4 - S1 All sitework shall:

- (a) meet the Technical Requirements
- (b) take account of the design
- (c) follow established good practice and workmanship

Sitework that complies with the design and the guidance below will be acceptable for finishings and fitments.

### CUPBOARDS AND FITMENTS

#### 8.4 - S2 Cupboards and fitments shall be installed to give satisfactory appearance and performance

Items to be taken into account include:

##### (a) pre-installation check

Cupboards and fitments should be checked to ensure they are undamaged before installation.

##### (b) correct location

Cupboards and fitments should be installed as shown in the design.

In the kitchen, a circulation space of not less than one metre should be provided in front of all work surfaces, cupboards and appliances.

##### (c) accurate levelling

All cupboards and worktops should be plumb and level and be scribed to wall faces, where necessary.

##### (d) adequate support and fixing

All wall units should be securely fixed, using:

- plugs and screws to masonry
- screws to timber studs, etc (fixings should be of appropriate size)
- appropriate proprietary fixings in accordance with manufacturers' instructions.

Use pre-drilled holes in units and brackets provided by the manufacturer, where appropriate.

Worktops spanning between units should be supported, where necessary.

Hanging rails should be provided in wardrobe cupboards, with intermediate supports, where necessary, to avoid bending.

##### (e) edge trim

Where worktops or unit panels are cut, edges should be sealed using a metal or plastic strip glued to the edge with waterproof adhesive. Alternatively, an appropriate waterproof joint may be used.

##### (f) sealing

Sinks and hob units, which are inset in worktops, and vanity units should be sealed with a waterproof joint.

Where appropriate, gaps between fitments and wall tiling should be sealed with a waterproof joint and brought to a smooth finish.

##### (g) operation of moving parts

For built-in fitments, doors should fit openings closely and evenly and operate freely; drawers should run smoothly, and locks and catches properly engage.

### FINISHINGS AND INTERNAL TRIM

#### 8.4 - S3 Finishings and internal trim shall be fixed to ensure a satisfactory finish free from unsightly blemishes

Items to be taken into account include:

##### (a) general workmanship

All trim should be sufficiently wide to mask joints.

Any trim in the vicinity of fireplaces, or other heat-producing appliances, should be:

- at the specified distance
- arranged to minimise movement and shrinkage.

Nails should be punched just below the timber surface and holes filled. Nails should never be driven home with the hammer head. As far as possible, any chipping, hammer marks or burrs should be avoided where easing is required and any damage made good.

##### (b) shelving

Shelving supports should be fixed securely and so that shelves are level. The specified distance between shelves in airing cupboards should be allowed.

##### (c) special features

Fireplace surrounds, panelling and other special features should be complete and joined satisfactorily to adjoining surfaces.

##### (d) architraves and skirtings

Architraves should be:

- parallel to frames and linings
- installed with an equal margin to each frame member

- fixed securely to linings to prevent curling.

Skirtings should:

- be mitred and scribed at external and internal angles, as appropriate
- tightly abut architraves as appropriate
- be run level and scribed to floors.

Skirtings and architraves of materials other than wood, eg those designed to accommodate trunking, should be fixed in accordance with the manufacturer's recommendations.

##### (e) painting, etc

Painting, staining, etc should be carried out in accordance with Chapter 8.5 'Painting and decorating' (each section).

##### (f) completion

All work should be left in a clean state.

### PROTECTION

#### 8.4 - S4 Completed work shall be handed over undamaged

Items to be taken into account include:

##### (a) kitchens

Kitchen units and complete fitted kitchens should be protected and, wherever possible, be left in the original wrappings until shortly before handover.

##### (b) special features

Appropriate protection for fireplace surrounds, panelling and other special features should be provided, where necessary.

##### (c) trim

Make sure that all completed skirtings, architraves, etc are adequately protected against damage from other trades.

##### (d) removal of coverings

All temporary coverings should be removed and all fitments and finishings cleaned and dusted shortly before handover.



**INDEX**

<b>A</b>			<b>L</b>			<b>T</b>		
Airing cupboards	2		Levelling	2		Timber	1	
Architraves	2		<b>M</b>			Trim	1, 2	
<b>C</b>			Moving parts	2		<b>W</b>		
Circulation space	1, 2		<b>N</b>			Wood	1	
Classification, timber	1		Nails	2		Wood based materials	1	
Completion	2		<b>P</b>			Workmanship	2	
Coverings	2		Painting	2		Worktops	2	
<b>F</b>			Particle board	1				
Features	2		Prefabricated items	2				
Fixing	2		Pre-installation check	2				
<b>H</b>			<b>S</b>					
Hanging rails	2		Sealing	2				
Hinges	1		Shelving	2				
<b>I</b>			Skirtings	2				
Installation	2		Staining	2				
Ironmongery	1		Storage space	1				
			Support	2				



# Chapter 8.5

## Painting and decorating

---



# 8.5 Painting and decorating

## CONTENTS

	Clause	Page
<b>DESIGN</b>		
Design standards	D1	1
Selection of paint and decorative systems	D2	1
Compatibility	D3	1
Provision of information	D4-D5	1
<b>MATERIALS</b>		
Materials standards	M1	1
Preservatives, stains and paints	M2	2
Prefabricated joinery	M3	2
<b>SITWORK</b>		
Sitework standards	S1	2
Prefabricated components	S2	2
Storage on site	S3	2
Timing	S4	2
Quality of finish	S5	2
Wallpapering	S6	3
<b>INDEX</b>		4

## SCOPE

This Chapter gives guidance on meeting the Technical Requirements and recommendations for painting and decorating.

## DESIGN STANDARDS

### 8.5 - D1 Design shall meet the Technical Requirements

Design that follows the guidance below will be acceptable for painting and decorating.

## SELECTION OF PAINT AND DECORATIVE SYSTEMS

### 8.5 - D2 Paint and decorative systems shall provide an acceptable finish

Paint or decorative systems should be selected and applied in accordance with BS 6150 'Code of Practice for painting of buildings'.

Items to be taken into account include:

#### (a) timber

##### DECORATIVE SYSTEMS

Decorative systems should be compatible with the surface to be decorated which may be:

- bare timber
- stained timber
- primed timber
- preservative treated timber
- naturally durable species.

##### STAIN SYSTEMS

Stain systems for timber should be either:

- a 2 coat system, or
- in accordance with manufacturers' recommendations.

##### PAINT SYSTEMS

Paint systems for timber should be either:

- at least one priming coat, one undercoat and one finishing coat, or
- proprietary systems in accordance with manufacturers' recommendations.

##### PRESERVATIVE TREATMENT

Painting or staining of external timber is required to provide protection and stability even if the timber is preservative treated, unless the preservative treatment manufacturer confirms otherwise (see Clause D3).

##### MOISTURE CONTENT

Wood with moisture content above 18% is not suitable for priming/painting.

#### (b) masonry and rendering

Paint or decorative finishes should not be applied to external brickwork or render where the finish could trap moisture in the construction causing frost damage or sulfate attack or other detrimental effects.

(This applies particularly to bricks which have no upper limit on their soluble salt content. The brick manufacturer's written agreement to the application of any finish should be obtained in such cases.)

Paint systems for external brickwork or render, including proprietary surface preparations, should be appropriate for

the substrate in accordance with the manufacturer's recommendations.

Where the decorative system is part of the weather resistance of the rendering, it should be assessed in accordance with Technical Requirement R3.

#### (c) metal

##### STRUCTURAL STEEL

Guidance on the protection of structural steel is given in BS EN ISO 12944 'Paints and varnishes. Corrosion protection of steel structures by protective paint systems' and BS EN ISO 14713 'Protection against corrosion of iron and steel in structures'.

Internal and external steel which has not been galvanized should be protected with at least two coats of zinc phosphate primer and a suitable decorative finish, where required.

Internal and external steel which has been galvanized to a rate of at least 460g/m<sup>2</sup> is acceptable without further protection. Steel galvanized to a rate of less than 460g/m<sup>2</sup> should be protected with at least two coats of zinc phosphate primer and a suitable decorative finish, where required.

Where steelwork is to be protected by intumescent paint for fire resistance, the manufacturer's recommendations should be followed.

##### GUTTERS

Insides of metal gutters (other than aluminium) should be painted with a suitable protective paint.

##### NON-FERROUS PIPEWORK

Copper pipes, etc should be painted with the normal decorative finishes.

#### (d) plaster and plasterboard

Plaster and plasterboard surfaces should be prepared in accordance with manufacturers' directions for:

- plastic compound finishes
- wallpapers
- emulsion paints, etc.

#### (e) proprietary building boards

Paint systems should be either:

- at least one priming coat, one undercoat and one finishing coat, or
- proprietary systems in accordance with manufacturers' recommendations.

Other finishes should be applied in accordance with manufacturers' recommendations.

## COMPATIBILITY

### 8.5 - D3 Paint and decorative systems shall be compatible with timber species and treatments

Items to be taken into account include:

#### (a) preservatives

Paint and stain systems specified should be compatible with any timber preservatives

that have been used. Where appropriate, manufacturers' recommendations should be obtained and followed.

#### (b) stains and varnishes

Stains and varnishes should be suitable for the species of timber to which they are applied. Where appropriate, manufacturers' recommendations should be obtained and followed.

BS 6952 gives recommendations on the use of exterior wood coating systems.

#### (c) glazing compounds

Linseed-oil putty should not be specified for glazing rebates in windows and doors treated with stains.

Appropriate sealants should be used in accordance with manufacturers' recommendations.

## PROVISION OF INFORMATION

### 8.5 - D4 Designs and specifications shall be produced in a clearly understandable format and include all relevant information

Design information should include:

- specification of preparatory work
- schedule of finishes.

### 8.5 - D5 All relevant information shall be distributed to appropriate personnel

Ensure that design and specification information is issued to site supervisors and relevant specialist subcontractors and/or suppliers.

## MATERIALS STANDARDS

### 8.5 - M1 All materials shall:

- (a) meet the Technical Requirements
- (b) take account of the design

Materials that comply with the design and the guidance below will be acceptable for painting and decorating.

Materials for painting and decorating should comply with all relevant standards, including those listed below. Where no standard exists, Technical Requirement R3 applies (see Chapter 1.1 'Introduction to the Standards and Technical Requirements').

References to British Standards and Codes of Practice include those made under the Construction Products Directive (89/106/EEC) and, in particular, appropriate European Technical Specifications approved by a European Committee for Standardisation (CEN).

# 8.5 Painting and decorating

## PRESERVATIVES, STAINS AND PAINTS

**8.5 - M2 Materials for use on non-durable building elements shall be selected to provide adequate protection**

Items to be taken into account include:

**(a) preservatives**

Timber preservatives should be selected in accordance with Chapter 2.3 'Timber preservation (natural solid timber)' (Materials).

**(b) knotting**

BS 1336 Specification for knotting.

However, knotting may not be effective against heavy exudation of resin which may disrupt finishes.

**(c) stains**

BS 6952 Exterior wood coating systems.

**(d) primers**

BS 4756 Specification for ready-mixed aluminium priming paints for woodwork

BS 5082 Specification for water-borne priming paints for woodwork

BS 5358 Specification for solvent-borne priming paints for woodwork.

**(e) proprietary paint systems**

Paint systems should be suitable in all respects for their intended use and situation. Selection should be in accordance with manufacturers' recommendations.

## PREFABRICATED JOINERY

**8.5 - M3 Prefabricated joinery shall be provided with adequate protection**

Protection in accordance with Clause M2 may be required.

Prefabricated joinery to be painted or stained should have been primed or given a first coat of stain or sealer before fixing.

Where primer is damaged, surfaces should be re-primed.

### SITWORK STANDARDS

**8.5 - S1 All sitework shall:**

**(a) meet the Technical Requirements**

**(b) take account of the design**

**(c) follow established good practice and workmanship**

Sitework that complies with the design and the guidance below will be acceptable for painting and decorating.

## PREFABRICATED COMPONENTS

**8.5 - S2 Prefabricated components to be painted or decorated shall be of suitable quality and adequately prepared**

Components to be painted, stained or sealed should have been primed (if to be painted) or given a first coat of stain or sealer before fixing.

Prefabricated joinery to be decorated should be supplied primed. Complete decoration should be carried out within the time specified by the manufacturer.

Components supplied untreated should have been stored under cover and be primed as soon as possible after delivery.

Where primer is damaged, surfaces should be re-primed.

## STORAGE ON SITE

**8.5 - S3 Materials and prefabricated components stored on site shall be adequately protected**

Items to be taken into account include:

**(a) painting materials**

Where it is necessary to store materials, the storage should ensure that the materials remain fit for use in the dwelling.

Water-borne paints, primers and stains should be protected against frost before use. Painting materials should not be used if they have been damaged by frost.

**(b) prefabricated components**

Where it is necessary to store components, the storage should ensure that they remain fit for use in the dwelling.

## TIMING

**8.5 - S4 Work shall only be carried out when conditions and surfaces are appropriate**

Items to be taken into account include:

**(a) external work**

External paintwork should not be carried out under weather conditions which may adversely affect the completed work.

Surfaces should be free from frost before painting commences and while paint dries.

Coatings should not be applied to moist surfaces, nor when rain is expected before the paint surface has set.

**(b) internal work**

When decorating internal walls, cold surfaces may cause problems with water-borne paints, even though the air temperature may be above freezing.

Surfaces should be free from condensation before applying paint. Coatings, especially those which are oil-based, should not be applied until all moisture has evaporated

from the surface. Internal paintwork should be left until the risk of dust and damage is minimal.

**(c) staining**

Staining should be carried out when the substrate is dry to ensure adequate dispersal and absorption.

## QUALITY OF FINISH

**8.5 - S5 Workmanship shall ensure a satisfactory finish**

Items to be taken into account include:

**(a) painting on wood**

**SURFACE PREPARATION**

Door and window furniture, sockets and light switches should be removed before painting to avoid over-painting and splashing.

Unsound wood, loose or highly resinous knots, etc should be cut out, replaced and made good.

Tool and machine marks and raised grain should be removed. Where a smooth surface is required, re-finish with glasspaper and fillers, as appropriate.

Nail holes, splits and other imperfections should be stopped. Sharp arrises should be rubbed down to ensure an even coating.

Surfaces to be painted should be free from dirt, dust and moisture.

All joinery delivered pre-primed to the site should meet the requirements given under PRIMING below.

Any surfaces showing deterioration of primer or seal coat should be rubbed down and a second coat applied.

Prefabricated joinery should have the first coat of paint or stain applied before fixing.

**PRESERVATIVES**

Before application, primer or paint finishes should be checked for compatibility with any timber preservatives that have been used.

Where appropriate, manufacturers' recommendations for selection and use of materials should be obtained and followed.

**KNOTTING**

All knots should be sealed using knotting applied by brush or in the case of joinery part of the priming process.

**PRIMING**

One full round coat of primer should be applied to all surfaces to be painted and to hidden surfaces of external woodwork.

Cut ends of external woodwork, rebates for glazing and backs of glazing beads should be primed.

**UNDERCOAT AND GLOSS**

Paint should not be thinned beyond the limits recommended by the manufacturer.

Unless an alternative recommendation is made by the manufacturer, the following should be applied:

- at least one undercoat (2 coats preferred), and
- one finishing coat.

The undercoat should provide a suitable base to ensure a satisfactory finishing coat. Additional undercoats or finishing coats are at the discretion of the Builder.

Each application should be a full round coat.

Surfaces should be lightly rubbed down between coats with glasspaper and each coat should be applied within one month of the application of the previous coat.

**(b) staining and varnishing on wood**

**SURFACE PREPARATION**

Before application, stains should be checked for compatibility with any timber preservatives that have been used. Stains should not be applied to door or window rebates to be glazed with linseed-oil putty.

Surfaces to be stained or varnished should be prepared to provide adequate adhesion and acceptable appearance.

**APPLICATION**

Low-build or high-build stain should be applied as recommended by the manufacturer to provide appropriate cover.

Varnish should be applied in at least three coats on interior surfaces. Exterior varnish (yacht or high gloss) should be applied in at least four coats. Surfaces should be sanded between coats.

**(c) painting on metal**

**STRUCTURAL STEEL**

Internal and external steel which has not been galvanized should be protected with at least two coats of zinc phosphate primer and a suitable decorative finish, where required.

Internal and external steel which has been galvanized to a rate of at least 460g/m<sup>2</sup> is acceptable without further protection. Steel galvanized to a rate of less than 460g/m<sup>2</sup> should be protected as steel which has not been galvanized.

Where steelwork is to be protected by intumescent paint for fire resistance, the manufacturer's recommendations should be followed.

**GUTTERS**

Insides of metal gutters (other than aluminium) should be painted with a suitable protective paint.

**NON-FERROUS PIPEWORK**

Copper pipes, etc should be painted with the normal decorative finishes.

**(d) painting on other surfaces**

**EXTERNAL MASONRY AND RENDERING**

Only materials specified should be used for external masonry or rendering.

Substrates should be clean and free from dust or loose deposits. Surfaces with varying suction may require stabilizing with a treatment recommended by the manufacturer.

**PLASTER AND SKIM COAT ON PLASTERBOARD**

Surfaces should be visibly sound and without powdering or crumbling.

All joints should be completed and any cracks, nail holes and surface imperfections filled. The surface should be rubbed down with glasspaper, if necessary, and dusted.

Surfaces require stabilizing, either with a coat of thinned paint or with a sealer recommended by the manufacturer.

Paint should then be applied in not less than two coats.

**DRY LINING**

A seal coat should be applied and surfaces prepared for decoration in accordance with manufacturers' recommendations.

**BUILDING BOARD**

Where painting is specified, surfaces should be primed or sealed and finished with at least two coats.

The first coat should be as recommended by the board manufacturer.

**(e) surface finish**

**QUALITY OF COMPLETED WORK**

All paintwork should be complete. Surfaces should be evenly coated and neither background nor undercoat should be visible.

Where brush marks, runs or abnormal roughness occur, work should be rubbed down and re-painted. Spilt, splashed or badly applied paint should be removed.

On completion, there should be no paintmarks on any surfaces not intended to be painted. On painted surfaces there should be no conspicuous runs or prominent brush marks. Ironmongery removed before painting should be re-fixed afterwards.

**PROTECTION**

Completed work should be protected against dirt and damage until the dwelling is handed over.

**WALLPAPERING**

**8.5 - S6 Wallpapering shall achieve a neat, consistent appearance**

Items to take into account include:

**(a) surface preparation**

Before any wallpapering is started, check that surfaces are dry and sufficiently even and smooth. Surfaces should be sized or sealed, if necessary.

To prevent stripping of the board lining paper, dry lining should be sized in accordance with manufacturers' recommendations.

Where proprietary coverings are used, any preparatory treatment recommended by the manufacturer should be applied.

**(b) choice of adhesive**

Adhesive of a type recommended by the wallpaper manufacturer should be used.

**(c) workmanship**

Wallpaper and coverings should be properly aligned and neatly fixed.

Electrical switch plates should be temporarily removed and the papering accurately trimmed so that it will tuck behind the switch plate on completion. Papers containing metal backings should not be tucked behind switch plates.



# 8.5 Painting and decorating

## INDEX

<b>A</b>		<b>J</b>		<b>R</b>	
Adhesive	3	Joinery, prefabricated	2	Rendering	1, 3
Application, stain or varnish	3	<b>K</b>		<b>S</b>	
<b>B</b>		Knotting	2	Stain systems	1, 2
Building boards	1, 3	<b>M</b>		Staining	2
<b>D</b>		Masonry	1	Storage	2
Decorative systems	1	Metal	1, 3	Structural steel	1, 3
Dry lining	3	Moisture content	1	<b>U</b>	
<b>E</b>		<b>P</b>		Undercoat	2
External work	2, 3	Paint systems	1, 2	<b>V</b>	
<b>F</b>		Pipework, non-ferrous	1, 3	Varnishing	3
Finish	3	Plaster	1, 3	<b>W</b>	
<b>G</b>		Plasterboard	1, 3	Wallpapering	3
Glazing compounds	1	Prefabricated components	2	Wood	2, 3
Gutters	1, 3	Preparation	2, 3	Workmanship	2, 3
<b>I</b>		Preservative treatment	1, 2		
Internal work	2	Priming	2		
		Proprietary building boards	1		
		Protection	2, 3		

---

# Part 9

## External works

---

9.1 Garages

9.2 Drives, paths and landscaping





# Chapter 9.1

## Garages

---



# 9.1 Garages

## CONTENTS

	Clause	Page
<b>DESIGN</b>		
Design standards	D1	1
Statutory requirements	D2	1
Garage foundations	D3	1
Garage floors	D4	1
Garage walls	D5	1
Resistance to fire spread	D6	2
Security	D7	2
Doors and windows	D8	2
Garage roofs	D9	2
Permanent prefabricated garages and carports	D10	3
Services	D11	3
Provision of information	D12-D13	3
<b>MATERIALS</b>		
Materials standards	M1	3
<b>SITWORK</b>		
Sitework standards	S1	3
<b>INDEX</b>		4

## SCOPE

This Chapter gives guidance on meeting the Technical Requirements and recommendations for integral, attached and detached garages.

## DESIGN STANDARDS

### 9.1 - D1 Design shall meet the Technical Requirements

Design that follows the guidance below will be acceptable for garages.

## STATUTORY REQUIREMENTS

### 9.1 - D2 Design shall comply with all relevant statutory requirements

Design should be in accordance with relevant Building Regulations and other statutory requirements.

## GARAGE FOUNDATIONS

### 9.1 - D3 Garage foundations shall transmit all loads to the ground safely and without undue movement

Garage foundations should support adequately the imposed loads, taking account of ground conditions. Further guidance is given in:

- Chapter 4.4 'Strip and trench fill foundations' (Design), and
- the guidance given below.

Items to be taken into account include:

#### (a) hazardous ground

For foundations on hazardous ground, the following Chapters are relevant:

- 4.1 'Land quality - managing ground conditions'
- 4.2 'Building near trees'
- 4.5 'Raft, pile, pier and beam foundations' (Design).

Any existing fill on the site of the garage should be examined and identified. Where any potential health hazard or risk of damage is indicated, appropriate precautions should be taken, as described in the following Chapters:

- 4.1 'Land quality - managing ground conditions'
- 5.1 'Substructure and ground bearing floors' (Design).

#### (b) type of foundation required for integral/attached garages

Foundations for integral or attached garages should be the same as those for the dwelling unless proper consideration is given to each foundation and the possibility of differential movement between them.

#### (c) type of foundation required for detached garages and blocks of garages

Design of foundations for detached individual garages or blocks of garages should avoid damage caused by differential loads and uneven settlement.

An unreinforced edge thickened concrete slab may be used where the ground is uniform and provides a satisfactory foundation bearing.

Unreinforced concrete slabs should:

- have a minimum thickness of 100mm
- have a minimum downstand thickening of 350mm below ground level around the whole perimeter of the slab
- have a minimum width of edge thickening of 300mm
- be constructed on 100mm minimum of properly compacted hardcore
- have dimensions not exceeding 6m in any direction - for dimensions greater than this, movement joints should be provided.

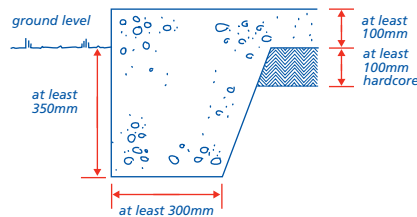

#### (d) adjacent structures

Foundations for garages should not impair the stability of the dwelling or any other adjacent structure.

#### (e) underground services

Garage foundations that are to be above or near services should be constructed so that no settlement of foundations or damage to services occurs (see Chapter 5.3 'Drainage below ground' (Design)).

#### (f) provision for movement

Movement joints in foundations should be provided:

- between dwellings and attached garages where there is a change of foundation type or depth
- at approximately 6m intervals where unreinforced concrete slab foundations are used.

## GARAGE FLOORS

### 9.1 - D4 Garage floors shall transmit all loads to either the foundations or the ground safely and without undue movement

Garage floors will be acceptable if they are in accordance with:

- Chapter 5.1 'Substructure and ground bearing floors' (Design), and
- Chapter 5.2 'Suspended ground floors' (Design), and
- the guidance given below.

Unless ventilation is specifically required for some other reason the void beneath a garage floor which is suspended precast concrete may be unventilated if:

- the floor has adequate durability, and
- the ground beneath is well drained, and
- there is unlikely to be a build up of soil gases.

Items to be taken into account include:

#### (a) bearing capacity of the ground

Where the depth of fill exceeds 600mm, concrete floors should be designed in accordance with Chapter 5.2 'Suspended ground floors' (Design) and BS 8103:Part 4.

Supporting fill should comply with the requirements of Chapter 5.1 'Substructure and ground bearing floors' (Sitework).

Where protection is needed to prevent attack by sulfates in either the ground, ground water or fill below the slab, an impervious isolating membrane should be provided between the concrete and the ground.

#### (b) resistance of the floor to moisture from the ground

Generally, a dpm is unnecessary except where:

- it is necessary to prevent dampness entering the dwelling, or
  - the floor has to be protected against chemical attack from the ground.
- Where no dpm is provided, the floor may show signs of dampness.

Where the floor is below ground level, precautions should be taken to prevent the entry of ground water by:

- tanking
- the use of dpcs and dpms
- drainage of the ground behind the wall to a level below the floor.

#### (c) thickness of floor slabs

Ground bearing floors, where provided, should not be less than 100mm thick, including a float finish.

#### (d) floor drainage

When practicable, garage floors should be laid to falls to ensure that water or spillage is directed out of the garage via the vehicle doorway.

#### (e) structural topping

Where reinforced screeds are to be incorporated as structural topping, they should be designed by an Engineer in accordance with Technical Requirement R5.

## GARAGE WALLS

### 9.1 - D5 Walls for all garages shall transmit all loads to foundations, safely and without undue movement

Garage walls will be acceptable if they are in accordance with:

- Chapter 5.1 'Substructure and ground bearing floors' (Design), and
- Chapter 6.1 'External masonry walls' (Design), and
- the guidance given below.

Items to be taken into account include:

#### (a) stability of walls above ground

Walls for detached garages and external walls for attached garages should:

- be not less than 90mm thick

# 9.1 Garages

- in the case of walls up to 200mm thick, have piers at corners (unless buttressed by a return) and at intermediate centres not exceeding 3m
- have adequate lateral restraint against wind loading.

## (b) stability of walls retaining ground

Garage walls retaining ground should be:

- suitable for the ground conditions
- structurally adequate.

Where garage walls act as retaining walls, they should be designed in accordance with Chapter 5.1 'Substructure and ground bearing floors' or by an Engineer in accordance with Technical Requirement R5.

## (c) provision for movement

Movement joints in garage walls, as described in BS EN 1996-2, should be provided:

- between dwellings and attached garages as required by Clause D3(f)
- where there are movement joints in foundations (reference should be made to Clause D3(f)).

## (d) adequate resistance to rain and ground water

A damp-proof course should be provided at a level at least 150mm above the level of adjacent ground. This dpc will protect the wall from rising ground moisture.

Garage walls constructed from a single leaf of masonry, such as brickwork or blockwork approximately 100mm thick, will not be impervious to wind driven rain and consequently could become damp.

In areas of severe exposure, single leaf walls may require a high standard of workmanship and possibly surface treatment to prevent an unacceptable level of rain penetration.

Where a garage is integral or attached, the design should ensure that dampness cannot enter the dwelling.

Where a wall is below ground level, precautions should be taken to prevent the entry of ground water by:

- tanking
- use of dpcs and dpms
- drainage of ground behind the wall.

## RESISTANCE TO FIRE SPREAD

### 9.1 - D6 Garages shall be constructed so as to prevent fire spread to the dwelling from the garage

Fire resistance between dwellings and integral or attached garages, may be provided by:

- a wall in brickwork, blockwork or fire-resisting studwork up to the underside of the roof covering

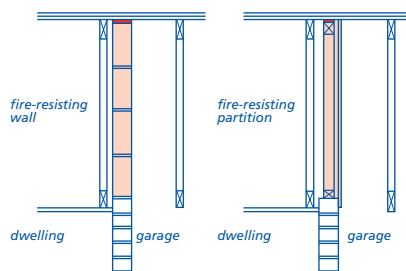

- a half-hour fire-resisting floor or ceiling

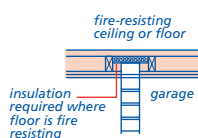

- any proposal which gives nominal half-hour fire resistance.

## SECURITY

### 9.1 - D7 Garages shall be constructed to provide reasonable security against unauthorised entry, in particular where garages are linked

Where garages in different ownership are linked, walls should prevent direct access from one garage to another.

## DOORS AND WINDOWS

### 9.1 - D8 Garage doors and windows shall be adequate for their purpose

Doors and windows will be acceptable if they are in accordance with:

- Chapter 2.3 'Timber preservation (natural solid timber)' (Design), and
- Chapter 6.7 'Doors, windows and glazing' (Design), and
- the guidance given below.

Items to be taken into account include:

#### (a) robustness

Frames should be selected and fixed having regard to the type and weight of the garage door.

#### (b) ease of operation

Proprietary doors and door gear should be installed in accordance with manufacturers' recommendations.

Care should be taken to ensure that garage doors are in proper working order at the time of handover of the dwelling.

## GARAGE ROOFS

### 9.1 - D9 Garage roofs shall satisfactorily resist the passage of rain and snow to the inside of the building, support applied loads and self weight and transmit the loads to the walls safely and without undue movement

Garage roofs will be acceptable if they are in accordance with:

- Chapter 7.1 'Flat roofs and balconies' (Design), and
- Chapter 7.2 'Pitched roofs' (Design), and
- the guidance given below.

Items to be taken into account include:

#### (a) holding down

To prevent uplift flat roofs and, where necessary, pitched roofs should be provided with holding down straps at not more than 2m centres where the roof members bear on the supporting wall. Straps should have a minimum cross section of 30mm x 2.5mm, be at least one metre long and have three fixings to the wall.

#### (b) bracing

The building designer should specify all bracing. Trussed rafter roofs should be braced in accordance with Table 1 in Appendix 7.2-C, unless the roof is designed and braced in accordance with BS 5268-3 (or PD 6693-2 when published).

All timber bracing to trussed rafters should be at least 100mm x 25mm in section and twice nailed to each trussed rafter. Nailing should be 3.35mm (10 gauge) x 65mm long galvanized round wire nails.

#### (c) fixing of corrugated roof coverings

Framing for corrugated coverings should be constructed and sheets laid to falls in accordance with manufacturers' recommendations.

#### (d) detailing at abutments

The following precautions should be taken at abutments between a garage roof and the main building or between stepped garages:

- flashings and weatherproofing should allow for differential movement
- cover flashings should be of metal or other approved material
- aprons and eaves fillers for corrugated coverings should fit the corrugation profile of the roofing
- cavity trays should divert water from inside the cavity to the external surface of the roof.

#### (e) movement

Movement joints should be provided:

- between dwellings and attached garages which have different types or depths of foundations (reference should be made to Clause D3(f))
- at approx 6m intervals where unreinforced slab foundations are used (reference should be made to Chapter 7.1 'Flat roofs and balconies' (Design)).



Movement joints in roofs should be continued through roof coverings and be provided with appropriate weather protection.

**(f) adequate disposal of rainwater**

The provision of rainwater disposal is at the discretion of the Builder, subject to statutory requirements and the paragraphs below.

Individual roofs, or combinations of roofs that drain from one to another with a total area greater than 6m<sup>2</sup>, should have a rainwater drainage system.

Where rainwater from a large roof surface discharges onto a garage roof, precautions should be taken to prevent premature erosion of the lower surface.

Rainwater should not discharge from the roof directly to a drive or path.

For details on the design of rainwater disposal systems, reference should be made to the following Chapters, as appropriate:

- 7.1 'Flat roofs and balconies' (Design)
- 7.2 'Pitched roofs' (Design).

**(g) acceptable forms of construction**

Garage roofs should be designed, specified and constructed as described in Chapter 7.1 'Flat roofs and balconies' (each section) or Chapter 7.2 'Pitched roofs' (each section), as appropriate.

## PERMANENT PREFABRICATED GARAGES AND CARPORTS

**9.1 - D10 Permanent prefabricated garages and carports shall be suitable for their intended purpose**

Permanent prefabricated garages and carports should:

- have appropriate foundations
- be structurally adequate
- provide appropriate weathertightness
- provide adequate separation between linked garages in different ownership.

Prefabricated garages should be erected in accordance with manufacturers' recommendations.

Particular care should be taken to ensure adequate holding down of carports and other light structures against wind action.

## SERVICES

**9.1 - D11 The provision of any service or appliance within a garage shall be in accordance with relevant regulations**

Where services or appliances are provided in garages, they should comply with the guidance below and with the following Chapters, as appropriate:

- 5.3 'Drainage below ground' (Design)
- 8.1 'Internal services' (Design).

Items to be taken into account include:

**(a) protection of water services against frost**

A rising main should not be located within a garage.

A water supply or outlet in a garage should have adequate provision for isolating and draining down.

Pipes should be insulated and located so as to minimise the risk of freezing.

**(b) provision of electricity**

The provision of electric lighting and socket outlets in a garage is at the discretion of the Builder.

All electrical installations should comply with BS 7671, formerly the Institution of Electrical Engineers (IEE) Wiring Regulations, operative on the date when the foundations of the dwelling are laid.

**(c) risk of fire or explosion**

Installation in a garage of an oil or gas burning boiler or heating appliance should be in accordance with any relevant Statutory Regulations.

## PROVISION OF INFORMATION

**9.1 - D12 Designs and specifications shall be produced in a clearly understandable format and include all relevant information**

Design information should include all necessary details of the following:

- exact location of garages
- all relevant levels, related to an agreed reference point
- foundations
- waterproofing, where applicable
- walls
- roof structure and coverings
- external and internal finishes
- services, where applicable.

**9.1 - D13 All relevant information shall be distributed to appropriate personnel**

Ensure that design and specification information is issued to site supervisors and relevant specialist subcontractors and/or suppliers.

## MATERIALS STANDARDS

**9.1 - M1 All materials shall: (a) meet the Technical Requirements (b) take account of the design**

Materials that comply with the design and the guidance given in the Chapters listed below will be acceptable for garages.

### FOUNDATIONS

- 4.4 'Strip and trench fill foundations' (Materials)
- 4.5 'Raft, pile, pier and beam foundations' (Materials)
- 5.1 'Substructure and ground bearing floors' (Materials)
- 6.1 'External masonry walls' (Materials).

### FLOORS

- 5.1 'Substructure and ground bearing floors' (Materials)
- 5.2 'Suspended ground floors' (Materials).

### WALLS

- 5.1 'Substructure and ground bearing floors' (Materials)
- 6.1 'External masonry walls' (Materials).

### ROOFS

- 7.1 'Flat roofs and balconies' (Materials)
- 7.2 'Pitched roofs' (Materials).

## SITWORK STANDARDS

**9.1 - S1 All sitework shall: (a) meet the Technical Requirements (b) comply with the design (c) follow established good practice and workmanship**

Sitework that complies with the design and the guidance given in the Chapters listed below will be acceptable for garages.

### FOUNDATIONS

- 4.4 'Strip and trench fill foundations' (Sitework)
- 4.5 'Raft, pile, pier and beam foundations' (Sitework)
- 5.1 'Substructure and ground bearing floors' (Sitework)
- 6.1 'External masonry walls' (Sitework).

### FLOORS

- 5.1 'Substructure and ground bearing floors' (Sitework)
- 5.2 'Suspended ground floors' (Sitework).

### WALLS

- 5.1 'Substructure and ground bearing floors' (Sitework)
- 6.1 'External masonry walls' (Sitework).

### ROOFS

- 7.1 'Flat roofs and balconies' (Sitework)
- 7.2 'Pitched roofs' (Sitework).

# 9.1 Garages

## INDEX

<b>A</b>		<b>F</b>		<b>P</b>	
Abutments, roofs	2	Fire resistance	2	Prefabricated garages	3
Attached garages	1	Fire risks	3	Protection	3
<b>B</b>		Fixing	2	<b>R</b>	
Blocks of garages	1	Floors	1, 3	Rainwater	2, 3
Bracing	2	Foundations	1, 3	Retaining walls	2
<b>C</b>		<b>G</b>		Roofs	2, 3
Car ports	3	Ground water	2	<b>S</b>	
Corrugated roof coverings	2	<b>H</b>		Screeds	1
<b>D</b>		Hazardous ground	1	Security	2
Detached garages	1	Holding down straps	2	Services	1, 3
Door openings	2	<b>I</b>		<b>U</b>	
Doors	2	Integral garages	1	Underground services	1
Drainage	1, 3	<b>M</b>		<b>W</b>	
<b>E</b>		Moisture resistance	1	Walls	1, 3
Electricity	3	Movement	1, 2	Water services	3
Explosion, risks	3			Windows	2

# Chapter 9.2

Drives, paths and landscaping

---



# 9.2 Drives, paths and landscaping

## CONTENTS

	Clause	Page
<b>DESIGN</b>		
Design standards	D1	1
Provision of access	D2	1
Freestanding walls and retaining structures	D3	1
Garden areas	D4-D7	1
Landscaping	D8	2
Provision of information	D9-D10	2
<b>MATERIALS</b>		
Materials standards	M1	2
Concrete	M2	2
All materials	M3	2
<b>SITWORK</b>		
Sitework standards	S1	2
Ground stability	S2	2
Foundations and construction	S3	3
Freestanding walls and retaining structures	S4	3
Garden areas	S5-S7	3
Landscaping	S8	3
<b>APPENDIX 9.2-A</b>		
Construction details of paved areas		4
<b>INDEX</b>		8

## SCOPE

This Chapter gives guidance on meeting the Technical Requirements and recommendations for private roads, shared private drives, private drives, car parking areas, paths and landscaping.

## DESIGN STANDARDS

### 9.2 - D1 Design shall meet the Technical Requirements

Design that follows the guidance below will be acceptable for private roads, drives, paths and landscaping.

In this Chapter “home” includes a house, bungalow, flat or maisonette. The “garden area” is the land within the curtilage up to 20m from the habitable parts of the home (i.e. not garages/outbuildings). This distance is measured from the external walls.

### PROVISION OF ACCESS

#### 9.2 - D2 Adequate access shall be provided to and around the home

Access should include the provision of private roads, shared private drives, private drives, car parking areas and paths as appropriate.

Items to be taken into account include:

##### (a) private roads, shared private drives, private drives and car parking areas

Where a private road, shared private drive, private drive or car parking area is constructed to provide access to, or around, a home it should be constructed to carry the likely loads from vehicles using it.

Drives forming part of the approach to certain entrances should comply with relevant Building Regulations.

Drives should be designed to permit a motor car reasonable access to and from a garage or car parking area.

Foundations, constructions and drainage suitable for private roads, shared private drives, private drives and car parking areas are given in Appendix 9.2-A.

Private roads, shared private drives and private drives should have a maximum gradient of 1:6. Where the gradient is more than 1:10 and the gradient changes, suitable transition lengths should be provided to reduce the risk of vehicles grounding. See Appendix 9.2-A.

##### (b) paths

Every home should have a path or paths within the curtilage to provide pedestrian access to the main entrance and a secondary entrance where present.

A path to a secondary access door is not required where entry to the home can be gained directly from a garage.

A path to a secondary entrance of a mid-terrace home or ground floor flat is not required.

Paths to certain entrances should comply with relevant Building Regulations.

If a garage, carport or car parking area is provided within the curtilage, a path should be provided to it from the home. Where appropriate, a drive can be regarded as a path for the provision of all or part of this access.

Path widths should be not less than the following:

- within curtilage to main or any entrance designated by Building Regulations 900mm
- paths used for the removal of refuse to the collection point 900mm
- paths adjoining a home 700mm
- where path is 100mm or more from the wall of a home 600mm
- all other cases 600mm

Paths should have gradients not exceeding 1:6. On steeper sloping ground, steps may need to be introduced at intervals to ensure that the maximum gradient of the path is not exceeded.

Foundations and constructions suitable for paths are given in Appendix 9.2-A.

##### (c) steps

Steps should be in accordance with Sitework clause 9.2 - S7.

##### (d) handrails and guarding to paths and steps

Handrails and guarding should be provided in accordance with Sitework clause 9.2 - S7.

### FREESTANDING WALLS AND RETAINING STRUCTURES

#### 9.2 - D3 Where provided, freestanding walls and retaining structures shall be adequate for their intended purpose

Items to be taken into account include:

##### (a) design

Freestanding walls should be designed in accordance with:

- BS EN 1996-1 Design of masonry structures, or
- BRE Good Building Guide 14.

All retaining structures, more than 600mm high, should be designed by an Engineer in accordance with Technical Requirement R5. Gabion and crib structures should not be used to provide support to homes, garages, roads, drives, car parking areas and drainage systems.

Retaining structures should be designed in accordance with:

- BS EN 1997-2 Geotechnical design: Ground investigation and testing
- BS EN 1992 Design of concrete structures
- BS EN 1996 Design of masonry structures

Where appropriate, brickwork and blockwork retaining walls may be designed in accordance with BRE Good Building Guide 27.

##### (b) guarding

Guarding should be provided where structures are retaining land more than 600mm high to which people have access.

Where steps and guarding are provided they should be designed in accordance with Sitework clause 9.2 - S7.

##### (c) planters

Where planters are provided they should be designed to adequately support the volume of retained soil and the plant species.

### GARDEN AREAS

#### 9.2 - D4 Garden areas shall be stable

Items to be taken into account include:

##### (a) slopes

Unless the stability of new or existing slopes has been determined by an Engineer in accordance with Technical Requirement R5 the following maximum gradients apply:

- unsupported granular soil should be 5° less than its natural angle of repose
- unsupported cohesive soil should not exceed 9° (1:6).

##### (b) retaining structures

Where it is necessary to provide retaining structures to ensure the stability of the ground they should be designed in accordance with Clause D3.

#### 9.2 - D5 Garden areas within 3m of the habitable part of the home shall not be waterlogged

Waterlogging of garden areas within 3m of the habitable part of the home should be prevented by drainage or other suitable means.

#### 9.2 - D6 Reasonable access shall be provided to garden areas

Access by steps or other suitable means should be provided to garden areas where appropriate. Access is not required to small isolated garden areas such as narrow strips of land at the top or bottom of retaining walls.

#### 9.2 - D7 Patios and decking shall be suitable for their purpose

Items to be taken into account include:

##### (a) patios

Foundations and constructions suitable for patios are given in Appendix 9.2-A.

# 9.2 Drives, paths and landscaping

## (b) timber decking

Timber used in the construction of decking should either be naturally durable or treated with preservative. See Chapter 2.3 'Timber preservation (natural solid timber)' (each section).

Decking and its support more than 600mm above ground level should be in accordance with guidance published by the Timber Decking Association or designed by an Engineer in accordance with Technical Requirement R5.

## LANDSCAPING

### 9.2 - D8 Possible future damage to the home caused by planting shall be minimised

Where trees or shrubs have been removed, are to be retained or are to be planted by the builder, precautions should be taken to reduce the risk of future damage to homes and services. These include:

- allowing sufficient space to preserve root systems
- allowing for root spread and water depletion, especially on clay soils
- allowing for the effects of water uptake where trees have been removed, especially on clay soils
- allowing for the future effects of tree and root growth
- providing foundation depths sufficient to allow for existing and new trees.

Guidance is given in Chapter 4.2 'Building near trees' and BS 5837.

## PROVISION OF INFORMATION

### 9.2 - D9 Designs and specifications shall be produced in a clearly understandable format and include all relevant information

All works relating to drives, paths and landscaping should be fully specified.

### 9.2 - D10 All relevant information shall be distributed to appropriate personnel

Ensure that relevant design and specification information is issued to site supervisors and relevant specialist subcontractors and/or suppliers.

## MATERIALS STANDARDS

### 9.2 - M1 All materials shall:

- (a) meet the Technical Requirements
- (b) take account of the design

Materials that comply with the design and the guidance below will be acceptable for drives, paths and landscaping.

Materials for drives, paths and landscaping should comply with all relevant standards, including those listed below. Where no standard exists, Technical Requirement R3 applies (see Chapter 1.1 'Introduction to the Standards and Technical Requirements').

References to British Standards and Codes of Practice include those made under the Construction Products Directive (89/106/EEC) and, in particular, appropriate European Technical Specifications approved by a European Committee for Standardisation (CEN).

## CONCRETE

### 9.2 - M2 Concrete shall be of a mix design which will:

- (a) achieve sufficient strength for its purpose
- (b) be sufficiently durable to remain unaffected by chemical or frost action

For guidance on the specification and use of concrete, reference should be made to Chapter 2.1 'Concrete and its reinforcement' (Design) and Appendix 9.2-A.

## ALL MATERIALS

### 9.2 - M3 All materials shall be suitable for their intended use

Items to be taken into account include:

#### (a) asphalts and macadam

Hot rolled and mastic asphalts and macadam should comply with relevant standards, including:

- BS 594 Hot rolled asphalt for roads and other paved areas
- BS 1447 Specification for mastic asphalt (limestone fine aggregate) for roads, footways and pavings in building
- BS 4987 Coated macadam for roads and other paved areas.

#### (b) sub-base material and aggregates

Sub-base for different road types should be Type 1 to clause 803 Table 8/2, MCHW1 Series 800.

Aggregates used in asphalt and macadam mixtures and unbound aggregate (graded 15/20 mm gravel) for surfacing should comply with relevant standards, including:

- BS EN 13043 Aggregates for bituminous mixtures and surface treatments for roads, airfields and other trafficked areas
- PD 6682 Part 2 - Guidance on the use of BS EN 13043
- BS EN 13242 Aggregates for unbound and hydraulically bound materials
- PD 6682 Part 6 - Guidance on the use of BS EN 13242.

#### (c) blocks, slabs and pavers

Blocks, slabs, pavers, edgings, etc should comply with relevant standards, including:

- BS EN 771 Specification for masonry units
- BS 6677 Part 1 : Clay and calcium silicate pavers for flexible pavements : Specification for pavers
- BS 6717 Precast, unreinforced concrete paving blocks - Requirements and test methods
- BS 7263 Precast concrete flags, kerbs, channels, edgings and quadrants
- BS 7533 Pavements constructed with clay natural stone or concrete pavers.

#### (d) materials for freestanding walls

Materials in accordance with BRE Good Building Guide 14 'Building brick or blockwork freestanding walls' will be acceptable.

#### (e) materials for retaining walls

Materials in accordance with BRE Good Building Guide 27 'Building brickwork or blockwork retaining walls' will be acceptable.

#### (f) timber decking

Materials in accordance with guidance published by the Timber Decking Association will be acceptable.

#### (g) topsoil

Topsoil quality should be such that it will not present a hazard to users of the garden area. BS 3882 and the Contaminated Land Exposure Assessment (CLEA) guidelines provide advice on determining the suitability of topsoil.

## SITWORK STANDARDS

### 9.2 - S1 All sitework shall:

- (a) meet the Technical Requirements
- (b) take account of the design
- (c) follow established good practice and workmanship

Sitework that complies with the design and the guidance below will be acceptable for private roads, drives, paths and landscaping.

## GROUND STABILITY

### 9.2 - S2 Precautions shall be taken on sloping sites to ensure stability of the ground

Where the ground may become surcharged during construction, precautions should be taken to ensure stability.

Retaining structures that give support to the foundations of a home should be completed before work starts on the construction of the foundations of the home. The use of gabion and crib structures to retain ground that gives support to homes, garages, roads, drives, and drainage systems is not acceptable to NHBC.

## FOUNDATIONS AND CONSTRUCTION

### 9.2 - S3 Foundations and construction for private roads, shared private drives, private drives, car parking and paths shall be appropriate for their use

Items to be taken into account include:

#### (a) specification

Appendix 9.2-A gives details of suitable constructions for private roads, shared private drives, private drives, car parking, paths and patios.

#### (b) protection of drains and services

Where underground drainage or services are below a private road, shared private drive, private drive, car parking area, path, or patio they should be protected against damage as described in Chapter 5.3 'Drainage below ground' (Design and Sitework).

#### (c) drainage

All private roads, shared private drives, private drives, car parking areas, should have adequate drainage and disposal. See Appendix 9.2-A.

Paths and patios abutting the home should generally be at least 150mm below the dpc and be laid to fall away from the home unless a channel or other suitable means of collection and disposal is provided.

#### (d) ground levels

Finished ground levels should be compatible with:

- dpc levels
- cover levels of drainage access points

- depth of underground services (gas, electricity, water, drains)
- drive and path levels.

#### (e) timber decking

Decking should be constructed in accordance with the design or guidance published by the Timber Decking Association.

#### (f) patios

Foundations and constructions suitable for patios are given in Appendix 9.2-A.

## FREESTANDING WALLS AND RETAINING STRUCTURES

### 9.2 - S4 Freestanding walls and retaining structures shall be adequate for their intended purpose

Items to be taken into account include:

#### (a) construction

Freestanding walls should be constructed in accordance with the design or BRE Good Building Guide 14.

Retaining structures should be constructed in accordance with the design or BRE Good Building Guide 27.

#### (b) guarding

Guarding should be provided to retaining walls more than 600mm high in accordance with Clause S7(a).

## GARDEN AREAS

### (up to 20m from the habitable parts of the home)

### 9.2 - S5 Garden areas shall be free from obstructions beneath the surface

Old foundations, concrete bases and similar obstructions occurring within 300mm of the finished ground surface should be removed.

### 9.2 - S6 Garden areas shall be adequately prepared for cultivation

Construction rubbish and debris should be removed from garden and other areas around the home.

The ground around the home can be compacted by machinery and storage of materials during construction as well as when topsoil is being replaced and this can affect the structure of the soil and its draining capability. Where this occurs within 3m of the home appropriate action should be taken to suitably restore the drainage characteristics of the soil.

Any ground disturbed during construction should be re-graded to conform to the general shape of the adjacent ground.

Subsoil should not be placed over topsoil and any topsoil disturbed should be reinstated. Garden areas should be

provided with topsoil to a thickness of not less than 100mm. The topsoil should not contain contaminants which are likely to present a hazard to users of the garden area.

### 9.2 - S7 Retaining structures and steps shall be adequately guarded and allow safe use

Items to be taken into account include:

#### (a) guarding and handrails

Guarding should be provided where:

- structures are retaining land more than 600mm high to which people have access, or
- a path is adjacent to a vertical difference in level of more than 600mm, or
- the ground adjacent to the path falls away at an angle of more than 30° from the horizontal, or
- the total rise of a flight of steps exceeds 600mm. A handrail should be provided.

The guarding should be at least 1100mm high, not readily climbable by children and a 100mm sphere should not be able to pass through any openings in the guarding.

#### (b) steps

Any steps should have a maximum rise of 220mm and a minimum going of 220mm.

## LANDSCAPING

### 9.2 - S8 Planting shall be completed in a manner appropriate for the site conditions and layout

If landscaping is specified, the work should be carried out and completed in a competent professional manner. Landscaping should meet with the guidance given in the Design section of this Chapter.

The NHBC recommendations on the protection and planting of trees should also be followed. See Chapter 4.2 'Building near trees' (each section).



## APPENDIX 9.2-A

**Table 1 Construction details of paved areas:**

The construction of private roads, shared private drives, private drives and car parking areas should be in accordance with the following or an equivalent alternative. (Thicknesses shown are in mm).

### Private road having frequent use by commercial vehicles

Construction (see Note 1)		Road type		
		Road (Bituminous Macadam)	Road (Block pavers)	Footpath (Bituminous Macadam)
Sub-base	Granular sub-base material Type 1 to clause 803 Table 8/2 MCHW1 Series 800 (see Note 2)	Table 2	150 (if CBR is 5% or less) (see Note 3) Table 2 (if CBR is greater than 5%)	225 (see Note 3)
Base (Road base)	Dense Bituminous Macadam (100/150 Pen paving grade bitumen) with crushed rock aggregate to BS 4987 (Group one mix)	100 (0/32mm size to clause 5.2)	N/A	N/A
	Concrete designation (BS 8500-2 Table 7)	N/A	N/A	N/A
Binder course (Base course)	Dense Bituminous Macadam (100/150 Pen paving grade bitumen) with crushed rock aggregate to BS 4987 (Group two mix)	60 (0/20mm size to clause 6.5)	60 (0/20mm size to clause 6.5)	60 (0/20mm size to clause 6.5)
Surface course (wearing course)	Dense Bituminous Macadam (100/150 Pen paving grade bitumen) with crushed rock aggregate to BS 4987 (Group three mix)	30 (0/10mm size to clause 7.4)	N/A	20 (0/6mm size to clause 7.5)
	Hot rolled asphalt to BS 594-1	40 (designation 30% 0/14)	N/A	N/A
	Mastic Asphalt to BS 1447	30 (Grade S - 40% 0/10mm size)	N/A	N/A
	Concrete designation (BS 8500-2 Table 7)	N/A	N/A	N/A
Bedding course	Sharp sand to BS 7533-3 category II of Annex D	N/A	50	N/A
Pavers	Block pavers To BS 6717 of Class markings W2, A2, and S3 (weathering, abrasion and slip/skid classes) (see Note 6)	N/A	80	N/A

#### Notes

- Names of pavement layers show both the European harmonised names and in brackets the names traditionally used in the UK.
- If a capping layer is specified then sub-base thickness can be reduced. DMRB Volume 7 Section 2 Part 2 HD 25/95 Foundations Chapter 3 Capping and Sub-base gives guidance on capping and sub-base thickness design based on CBR values and with and without a capping layer.
- Thickness is based on the provision of a geotextile membrane underneath the sub-base. If no geotextile membrane is provided see Table 2.
- Bond and tack coat should be provided for bituminous mixtures in accordance with BS 4987-2 or BS 594-2.
- Asphalt based materials can be used as partial replacement of full thickness of granular sub-base Type 1 material.
- When laid to either 90 or 45 degrees herringbone pattern then the edge perimeter to be laid with one single row of stretcher bond set parallel to the edge restraint. Where block pavers are laid abutting drainage channels, gully grates and the like, the upper surface of the block pavers shall be set between 3 and 6mm above the grating. Manufacturer's declared value markings W3 and S4 are acceptable if W3 is 1.0 kg/m<sup>2</sup> or less and S4 is 45 or more based on 'C scale unit' (with regard to abrasion, Class A2, no test result is greater than 23mm; and Class A1 = no performance determined).
- Use 38mm thickness of graded 15/20mm unbound aggregate to BS EN 13242 (gravel) well rolled and compacted.
- N/A = Not Applicable

**Shared parking and associated access areas having frequent use by commercial vehicles**

Construction (see Note 1)		Road type	
		Bituminous Macadam	Block pavers
Sub-base	Granular sub-base material Type 1 to clause 803 Table 8/2 MCHW1 Series 800 (see Note 2)	Table 2	Table 2
Base (Road base)	Dense Bituminous Macadam (100/150 Pen paving grade bitumen) with crushed rock aggregate to BS 4987 (Group one mix)	80 (0/32mm size to clause 5.2)	N/A
	Concrete designation (BS 8500-2 Table 7)	100 Grade GEN2 (see Note 4)	N/A
Binder course (Base course)	Dense Bituminous Macadam (100/150 Pen paving grade bitumen) with crushed rock aggregate to BS 4987 (Group two mix)	60 (0/20mm size to clause 6.5)	N/A
Surface course (wearing course)	Dense Bituminous Macadam (100/150 Pen paving grade bitumen) with crushed rock aggregate to BS 4987 (Group three mix)	30 (0/10mm size to clause 7.4)	N/A
	Hot rolled asphalt to BS 594-1	N/A	N/A
	Mastic Asphalt to BS 1447	N/A	N/A
	Concrete designation (BS 8500-2 Table 7)	N/A	N/A
Bedding course	Sharp sand to BS 7533-3 category II of Annex D	N/A	50
Pavers	Block pavers To BS 6717 of Class markings W2, A2, and S3 (weathering, abrasion and slip/skid classes) (see Note 6)	N/A	80

**Shared drives having infrequent use by commercial vehicles**

Construction (see Note 1)		Road type			
		Bituminous Macadam	Concrete	Block pavers	Gravel
Sub-base	Granular sub-base material Type 1 to clause 803 Table 8/2 MCHW1 Series 800 (see Note 2)	Table 2	Table 2	Table 2	Table 2
Base (Road base)	Dense Bituminous Macadam (100/150 Pen paving grade bitumen) with crushed rock aggregate to BS 4987 (Group one mix)	see Note 5	N/A	N/A	N/A
	Concrete designation (BS 8500-2 Table 7)	N/A	N/A	N/A	N/A
Binder course (Base course)	Dense Bituminous Macadam (100/150 Pen paving grade bitumen) with crushed rock aggregate to BS 4987 (Group two mix)	80 (0/32mm size to clause 6.4) or (0/20mm size to clause 6.5)	N/A	N/A	N/A
Surface course (wearing course)	Dense Bituminous Macadam (100/150 Pen paving grade bitumen) with crushed rock aggregate to BS 4987 (Group three mix)	30 (0/10mm size to clause 7.4)	N/A	N/A	see Note 7
	Hot rolled asphalt to BS 594-1	40 (designation 30% 0/14)	N/A	N/A	N/A
	Mastic Asphalt to BS 1447	30 (Grade S - 40% 0/10mm size)	N/A	N/A	N/A
	Concrete designation (BS 8500-2 Table 7)	N/A	150 Grade PAV2	N/A	N/A
Bedding course	Sharp sand to BS 7533-3 category II of Annex D	N/A	N/A	50	N/A
Pavers	Block pavers To BS 6717 of Class markings W2, A2, and S3 (weathering, abrasion and slip/skid classes) (see Note 6)	N/A	N/A	80	N/A

Table 1 continued

**Private drives and parking areas having use by cars and light vehicles**

Construction (see Note 1)		Road type			
		Bituminous Macadam	Concrete	Block pavers	Gravel
Sub-base	Granular sub-base material Type 1 to clause 803 Table 8/2 MCHW1 Series 800 (see Note 2)	Table 2	Table 2	Table 2	Table 2
Base (Road base)	Dense Bituminous Macadam (100/150 Pen paving grade bitumen) with crushed rock aggregate to BS 4987 (Group one mix)	N/A	N/A	N/A	N/A
	Concrete designation (BS 8500-2 Table 7)	N/A	N/A	N/A	N/A
Binder course (Base course)	Dense Bituminous Macadam (100/150 Pen paving grade bitumen) with crushed rock aggregate to BS 4987 (Group two mix)	60 (0/20 mm size to clause 6.5)	N/A	N/A	N/A
Surface course (wearing course)	Dense Bituminous Macadam (100/150 Pen paving grade bitumen) with crushed rock aggregate to BS 4987 (Group three mix)	20 (0/6mm size to clause 7.5)	N/A	N/A	see Note 7
	Hot rolled asphalt to BS 594-1	N/A	N/A	N/A	N/A
	Mastic Asphalt to BS 1447	N/A	N/A	N/A	N/A
	Concrete designation (BS 8500-2 Table 7)	N/A	100 Grade PAV 1	N/A	N/A
Bedding course	Sharp sand to BS 7533-3 category II of Annex D	N/A	N/A	50	N/A
Pavers	Block pavers To BS 6717 of Class markings W2, A2, and S3 (weathering, abrasion and slip/skid classes) (see Note 6)	N/A	N/A	50	N/A

**Notes**

- Names of pavement layers show both the European harmonised names and in brackets the names traditionally used in the UK.
- If a capping layer is specified then sub-base thickness can be reduced. DMRB Volume 7 Section 2 Part 2 HD 25/95 Foundations Chapter 3 Capping and Sub-base gives guidance on capping and sub-base thickness design based on CBR values and with and without a capping layer.
- Thickness is based on the provision of a geotextile membrane underneath the sub-base. If no geotextile membrane is provided see Table 2.
- Bond and tack coat should be provided for bituminous mixtures in accordance with BS 4987-2 or BS 594-2.
- Asphalt based materials can be used as partial replacement of full thickness of granular sub-base Type 1 material.
- When laid to either 90 or 45 degrees herringbone pattern then the edge perimeter to be laid with one single row of stretcher bond set parallel to the edge restraint. Where block pavers are laid abutting drainage channels, gully grates and the like, the upper surface of the block pavers shall be set between 3 and 6mm above the grating. Manufacturer's declared value markings W3 and S4 are acceptable if W3 is 1.0 kg/m<sup>2</sup> or less and S4 is 45 or more based on 'C scale unit' (with regard to abrasion, Class A2, no test result is greater than 23mm; and Class A1 = no performance determined).
- Use 38mm thickness of graded 15/20mm unbound aggregate to BS EN 13242 (gravel) well rolled and compacted.
- N/A = Not Applicable

Table 2 Minimum sub-base thickness for paved areas:

California Bearing Ratio (CBR) values	Minimum thickness (mm) of sub-base (Consolidated in accordance with MCHW Volume 1 clause 801, table 8/1).	
	Without Geotextile underneath	With Geotextile underneath
Less than 2%	N/A	300
2% - 3%	325	225
3% - 5%	250	150
5% - 7%	150	
7% - 20%	100	

**Notes**

The thickness of any required capping layer and the sub-base should be determined after investigations and on-site tests have been carried out relating to the California Bearing Ratio (CBR) value and frost susceptibility of the sub-grade. See table 2.

Where the tests indicate that the sub-grade is frost susceptible a suitable capping layer should be included below the sub-base, to a depth that will ensure that the construction will not be affected by frost heave.

## GENERAL

All works should be completed in accordance with:

- the design, and
- the ground remediation statement where applicable.

All vegetable matter should be removed from the area of the proposed works.

Formation levels should be set out in accordance with the design.

Only suitable fill material comprising clean, well consolidated crushed rock, hardcore, slag or concrete should be used to make up levels.

The sub-base should be mechanically consolidated in layers not exceeding 225mm.

### Construction of paved areas

All sub-base levels should have the same longitudinal gradient and cross-fall as the finished levels.

Private roads, shared private drives and car parking areas should have adequate falls, cross-falls and suitable drainage to ensure that surface water is disposed of.

Where it is intended to use porous or permeable surfaces as part or all of the rainwater drainage system reference should be made to CIRIA report C522 - Sustainable urban drainage systems - design manual for England and Wales.

Surfaces should not be laid flatter than 1:40 or have a camber of 1:40 if no fall is available to avoid "flat spots".

Surface water from private areas should not drain onto adopted areas.

Surfaces of private drives and paths should be laid to a minimum finished fall of 1:80 away from the home including a garage. Alternatively a channel or other suitable means of collection and disposal should be provided adjacent to the home.

Vertical alignment, finished levels, transition arrangements and gradients should be in accordance with the design.

Edge restraint or kerbing should have a profile and foundation which is suitable to form a permanent supporting edge for the expected vehicle loads using the road or drive.

Any soakaway should be located in open or garden areas at least 2m away from any paved area.

## HOUSE PATHS AND PATIOS

### Sub-base

The sub-base should comprise of a 100mm thickness of clean, well consolidated crushed rock, hardcore (max size 75mm), slag or concrete, the surface of which is blinded with 25mm of sand.

## Paving slabs

Paving slabs should be fully bedded in 25mm 1:4 cement : sand mortar or a suitable alternative.

Where paving slabs are laid abutting drainage channels, gully grates and the like, the upper surface of the paving slab should be set approximately 5mm above the grating.

## Concrete

Concrete should be not less than 75mm thick and have a tamped or textured finish. The concrete mix should be suitable to give a durable and frost resistant surface, as described in Chapter 2.1 'Concrete and its reinforcement' (Design). Movement joints, not less than 10mm wide, should be provided across the full width of the path at not more than 4m centres. A movement joint is not required at the abutment with a wall unless the opposite edge of the concrete is also restrained.

## TRANSITION LENGTHS

Transition lengths should be incorporated into drives and ramps with a gradient of more than 1:10.

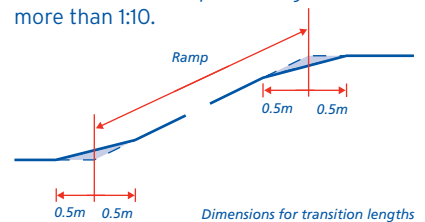

## Note

Maximum drive gradient is 1:6.

## INDEX

<b>A</b>		<b>G</b>		<b>R</b>	
Access	1	Gabions	1, 2	Retaining structures	1, 2
Aggregates	2	Garden areas	3	<b>S</b>	
Asphalt	2	Grading	1, 3	Services	3
<b>B</b>		Ground levels	3	Shared private drive	1
Blocks	2	Guarding	1	Shrubs	2
<b>C</b>		<b>H</b>		Slabs	2
Car parking	3	Handrails	1	Slopes	1
Concrete	2, 3	<b>L</b>		Stability, ground	2
Concrete slabs, precast	2	Landscaping	2, 3	Steps	1
<b>D</b>		<b>M</b>		<b>T</b>	
Damage to buildings	2	Macadam	2	Timber decking	3
Drains	3	Materials	2	Trees	2, 3
Drives	1	<b>P</b>		<b>W</b>	
<b>F</b>		Paths	1	Walls	1, 2
Foundations	1, 3	Pavers	2, 3	Waterlogging	1
Freestanding walls	2	Patios	3	Widths - paths	1
		Planters	1		
		Private drives	1		
		Private roads	1		



NHBC Standards 2013 have been printed on material which is produced from sustainable forests and is fully recyclable and biodegradable, ECF (elemental chlorine free) and is made to ISO 14001 Environmental Certification.



NHBC  
NHBC House, Davy Avenue, Knowlhill, Milton Keynes MK5 8FP  
Tel: 0844 633 1000 Fax: 0844 633 0022 [www.nhbc.co.uk](http://www.nhbc.co.uk)  
NHBC is authorised and regulated by the Financial Services Authority