

Restraint straps to masonry gable walls of garages

(November 2022) (Fourth issue supersedes July 2020)



Question

Are lateral restraint straps needed to the masonry gable walls of garages?

Considerations

- NHBC Standards clause 10.1.5 says that garage walls should have adequate lateral restraint against wind loading.
- NHBC Standards clause 7.2.8 refers to restraint strapping for gable walls of dwellings of masonry construction to provide lateral restraint.
- BS 8103 Parts 1 and 2 'Structural design of low-rise buildings' gives guidance on the provision of lateral restraint to masonry walls.

Answer

For garages of masonry construction, the gable should be restrained at rafter level with restraint straps. Restraint should also be provided at ceiling level where the height (h) exceeds:

- $16x$ thickness of the wall for single leaf walls.
- $16x$ (sum of thicknesses of leaves + 10mm) for cavity walls.

Note: 'h' should be measured from top of foundation or from the underside of the floor slab where this provides effective lateral restraint.

The restraint at rafter level may be provided by restraint straps or by a gable ladder (see NHBC Standard 7.2.8).

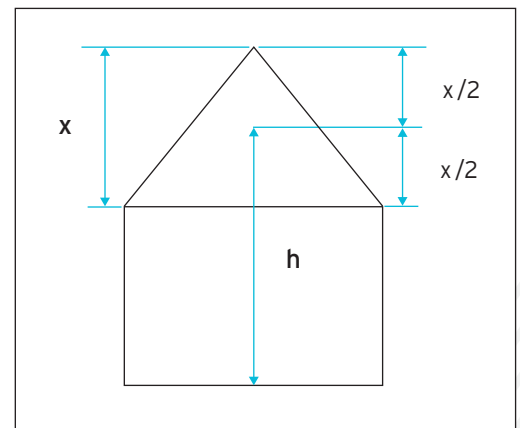

Where straps are used they should have a minimum cross section of 30mm x 5mm or be proprietary straps that have been designed for lateral restraint purposes.

Straps should be fixed to the rafters with solid blocking (or be fixed to the longitudinal bracing (see NHBC Standard 7.2.8))

For cavity walls the straps should be at 2m maximum centres, with the top strap near the apex of the gable.

For solid walls it will normally be necessary to fix the straps to the inside face with at least two 6mm x 30mm plug and screw fixings per strap. Unless the design states otherwise the restraint straps should be provided at the following positions:

- Walls constructed of solid bricks - two restraint straps per roof slope at maximum 2m centres plus one extra strap near the apex of the gable.
- Walls constructed of perforated bricks/blocks or concrete/aerated concrete blocks - three restraint straps per roof slope at maximum 1.5m centres.

Note: For the purposes of lateral restraint a 'perforated' brick/block is where the perforations (vertical holes) represents more than 25% of the volume of the brick/block.

